



ZROADZ

DYNAMIC LED MOUNTING SOLUTIONS



PROFESSIONAL INSTALL RECOMMENDED

2017 FORD F-250 / F-350

PART#: Z335471 / Z335471-KIT-C

FRONT ROOF LED LIGHT MOUNTS

PARTS ARE PATENT PENDING. ALL RIGHTS RESERVED - COPYRIGHT ©2017 - ZROADZ LED, INC.

PARTS INCLUDED

- (1) - Driver Side Roof Mount Upright
- (1) - Passenger Side Roof Mount Upright
- (1) - Driver Side Curved Coupler
- (1) - Passenger Side Curved Coupler
- (1) - Driver Side Straight Coupler
- (1) - Passenger Side Straight Coupler
- (1) - Hardware Pack



* Simulated Rendering, Not actual parts.

LED LIGHTS INCLUDED

Z335471 - No LED Lights Included

Z335471-KIT-C - (1) ZROADZ 52" Curved LED Light Bar

HARDWARE INCLUDED

Z335471

- (1) - Weather Proof Rubber Boot
- (1) - 3/16 DIA. Wire Clip Mount
- (2) - 1/2 x 20 Hex Nut
- (2) - 1/2 Split Lock Washer
- (8) - 10-32 x .625 Button Head Allen Cap Stainless Steel Screws
- (8) - 10/32 Nylock Stainless Steel Nuts
- (11) - M5 Hex Bolts
- (11) - M5 Washers
- (2) - Moulding Plates
- (1) - Driver Side Bottom Plate Gasket
- (1) - Passenger Side Bottom Plate Gasket

Z335471-KIT-C

- (1) - Weather Proof Rubber Boot
- (1) - 3/16 DIA. Wire Clip Mount
- (2) - 1/2 x 20 Hex Nut
- (2) - 1/2 Split Lock Washer
- (8) - 10-32 x .625 Button Head Allen Cap Stainless Steel Screws
- (8) - 10/32 Nylock Stainless Steel Nuts
- (11) - M5 Hex Bolts
- (11) - M5 Washers
- (2) - Moulding Plates
- (1) - Driver Side Bottom Plate Gasket
- (1) - Passenger Side Bottom Plate Gasket
- (1) - Torx Bit T-40
- (2) - M8 Tamper Proof Bolt
- (2) - M8 Split Lock Washer

TOOLS REQUIRED

- Drill & Tapered Drill Bit
- Air Hose & Nozzle
- Alcohol Cleaning Solution
- Cleaning Rag
- Socket Set & Ratchet Tool
- Ratchet Extensions
- Various Wrenches
- Dikes or Snips
- Torq Bit Set
- Heat Gun

MATERIALS NEEDED - Clear RTV Silicone
- 1/2" x 1/4" DIA Shrink Tube

INSTALLATION GUIDE

START HERE

PLEASE READ AND UNDERSTAND ALL INSTRUCTIONS BEFORE INSTALLATION. Auto makers offer varied models to each vehicle and occasionally manufacture more than one body style of the same model.

* APPLICATION MODELS VARY. WE RECOMMEND TO VERIFY FITMENT BEFORE BEGINNING INSTALLATION PROCESS.
* IMAGES FEATURED IN THE INSTRUCTION DOCUMENTS MAY NOT ALWAYS EXACTLY MATCH YOUR MODEL OR PART.

BEFORE YOU BEGIN

LED LIGHT BRACKET INSTALLATION

IMPORTANT NOTE: The installation requires additional cutting and removal of material inside vehicle cab. The A-Pillar Air Bag will also need to be dropped and pushed aside. If you are not comfortable with this, stop installation and consult a professional.

START HERE: Turn off engine, chalk tires with stop block, open the hood and disconnect the battery.

STEP 1

1) First, Clean the base of the supplied roof brackets with alcohol. Apply the provided bottom plate gaskets.



STEP 2

SEE FIGURES 2 & 3

2) Make sure to align the gaskets so that the holes, down tube, and front square opening are properly fitted with base plate to gasket.

Note there is a left side gasket and a right side gasket.

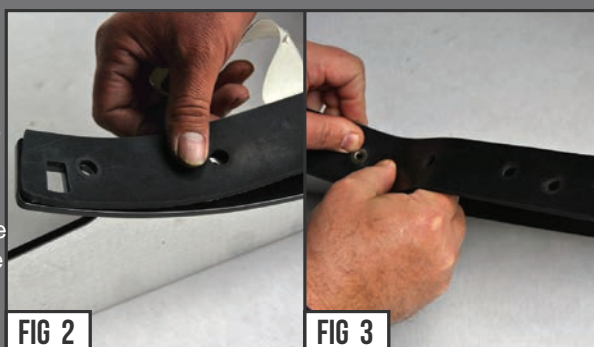



ROOF MOUNT INSTALLATION - CONTINUED

PARTS ARE PATENT PENDING. ALL RIGHTS RESERVED - COPYRIGHT ©2017 - ZROADZ LED, INC.



FIG 4



FIG 5

STEP 3

3) The ZROADZ Brackets have distinguished Passenger Side and Driver Side Uprights and could be noted by the brushed aluminum interior plate. The outside features the black powder coated steel plate with Logo Markings.

STEP 4

SEE FIGURE 5

4) Remove exterior trim piece that covers the vehicle cab seam to side.



FIG 6

REMOVE TRIM PIECE



FIG 7

STEP 4

SEE FIGURE 6

4) Start from the rear of the cab where the trim piece clips to a button.

STEP 5

SEE FIGURES 7-8-9

5) Gently pull the fastener loose and continue pry up and forward all the way to the front.

Note the very front of the vehicle cab is a forward facing tab the holds the trim piece down from the front.

Perform this step for both sides of the roof.



FIG 8



FIG 9



ROOF MOUNT INSTALLATION - CONTINUED

PARTS ARE PATENT PENDING. ALL RIGHTS RESERVED - COPYRIGHT ©2017 - ZROADZ LED, INC.



FIG 10

STEP 6

SEE FIGURE 10

6) AT this point you will need to drop the interior roof upholstery.

INSTALLERS NOTE

This is a necessary and important step so that you can temporarily drop and push to the side the air bags and any other critical equipment stuffed up in between roof cab and the interior which will ensure critical components are not damaged.



FIG 11

STEP 7

SEE FIGURES 11 - 12

7) 2017 Ford F-250 / F-350 model vehicles feature an aluminum cab structure that is bolted together at the roof seam.

Starting on the Driver Side at the windshield and working your way backwards, remove first (6) bolts.



FIG 12

FIT ROOF MOUNT BRACKET



FIG 13

STEP 8

SEE FIGURES 13 - 14

8) Referencing Figure #13, note the Driver Side Upright and the down tube location will align with the vehicle cab bolt hole #2. Use the tapered drill bit and bore out the bolt hole to a final diameter of 1/2" and just enough so that the down tube nub will fit snugly in place.

NOTE: No Drilling is required on the Vehicle Cab's Passenger Side.



FIG 14

STEPS 9 & 10

SEE FIGURES 15 - 16

9) With the hole drilled through, clean off all drilling debris and flash INSIDE AND OUTSIDE OF THE DRILL HOLE LOCATIONS. This is a very important to create a flush sealing surface and you do not want to leave any chance of rust occurring.

10) Put into place the Bracket Mount Upright and slip the bracket under the tab as seen in Figure #16.



FIG 15



FIG 16

LED LIGHT ROOF MOUNT INSTALLATION - CONTINUED



ROOF MOUNT INSTALLATION - CONTINUED

PARTS ARE PATENT PENDING. ALL RIGHTS RESERVED - COPYRIGHT ©2017- ZROADZ LED, INC.



FIG 17



FIG 18

STEP 11

SEE FIGURE 17

11) Double check the Bracket Mount is properly positioned and aligned with the vehicle cab bolt holes.

Once confirmed, dab a thin layer of clear RTV Silicone in and around the outside of each hole to help with weather proofing and sealing.

STEP 12

SEE FIGURE 18

12) Proceed with securing the Bracket Mounts to Vehicle Cab by placing the provided Hex Bolts and Washers into position (exposed Vehicle Cab Bolt Holes).



FIG 19

STEP 13

SEE FIGURE 19

13) Tighten down each Hex Bolt w/ Washer. Start at the front and then move to the back working your way towards the middle.

NOTE: Leave the last Hex Bolt somewhat loose to allow for Step # 15 to be completed.

CUT DOWN ROOF EXTERIOR TRIM PIECE



FIG 20



FIG 21

STEPS 14 & 15

SEE FIGURES 20-22

14) Take the Vehicle's Exterior Trim Piece and hover it close to where the ZROADZ Bracket Mount Bottom Plate ends. Mark the Trim Piece so that when it is cut down, the Trim will fit back down into the Roof Channel.

15) Carefully and cleanly cut down the Trim Piece and then insert the provided Moulding Plate into position as seen in Figure #22.

Put into position the Exterior Trim Piece so that it is secured under the Moulding Plate and re-attach all the fasteners.

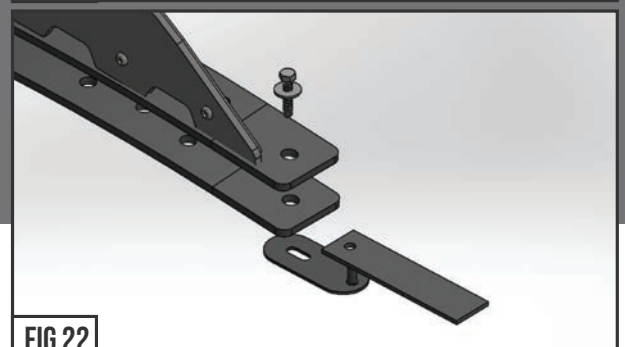

FIG 22

LED LIGHT ROOF MOUNT INSTALLATION - CONTINUED



ROOF MOUNT INSTALLATION - CONTINUED

PARTS ARE PATENT PENDING. ALL RIGHTS RESERVED - COPYRIGHT ©2017 - ZROADZ LED, INC.



STEP 16

16) Obtain the supplied security torx, lock washer and tool bit from the hardware pack.

STEP 17

17) With a friend's help, install the 52" light to the brackets with the wire on the drivers side.

SEE FIGURES 23 - 25



LED LIGHT INSTALL



STEP 18

18) Tighten hardware by giving the torx bit some extra leverage.

SEE FIGURE 28



STEPS 19

19) Secure the wire to the driver bracket with supplied wire clip and nut. Leave slack in the wire from LED to the wire clip for some movement & available adjustment.

SEE FIGURE 29



LED LIGHT ROOF MOUNT INSTALLATION - CONTINUED



ROOF MOUNT INSTALLATION - CONTINUED

PARTS ARE PATENT PENDING. ALL RIGHTS RESERVED - COPYRIGHT ©2017 - ZROADZ LED, INC.



FIG 30



FIG 31

STEPS 20

SEE FIGURE 30

20) Cut the LED light wires. Leave enough room for the insulation to be removed and the red and black wires to pass through the roof via the "Through Bolt Down Tube".

STEP 21

SEE FIGURE 31

21) Trim back a large amount of the insulation sheath off the LED Wires so that you can slip them through the rubber weather proofing boot.

To expose the wires, a sharp razor could easily splice open the insulation sheath.

WIRING PLUMBING



FIG 32



FIG 33

STEPS 22

SEE FIGURES 32 & 33

22) Install 1/4" heat shrink insulation over wires as shown in Figure #32. Shrink insulation with heat gun or similar.



FIG 34

STEPS 23

SEE FIGURES 34 - 36

23) Use a 50/50 mix of dish soap and water solution to install supplied boot over wire as shown in Figure #36.

Pass the wire through the tube. Use a liberal amount of solution on the bracket around the area where the boot installs to aid in slipping the boot over the post.

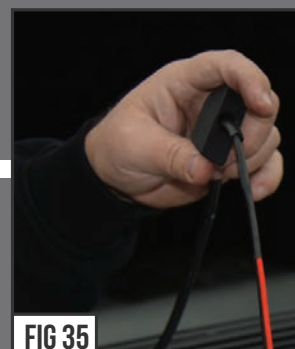

FIG 35

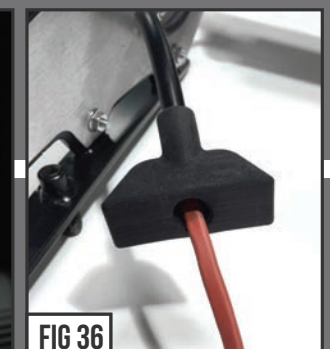

FIG 36



FIG 37



ZROADZ

DYNAMIC LED MOUNTING SOLUTIONS

ROOF MOUNT INSTALLATION - CONTINUED

PARTS ARE PATENT PENDING. ALL RIGHTS RESERVED - COPYRIGHT ©2017 - ZROADZ LED, INC.



FIG 38



FIG 39

STEPS 24

SEE FIGURE 38

24) Stuff the boot into the bracket opening and over the down tube upright.

STEP 25

SEE FIGURES 39 - 41

26) With the rubber boot fully seated (as seen in Figures #40 & #41) you are now ready to finish wiring up the LED Light bar to a wiring harness.

After wiring is complete, re-install vehicle's interior in the reverse order it was removed according to industry "R&R" method.

FINAL INSTALLATION



FIG 40



FIG 41



FIG 42

STEP 20

20) Wire LED Light with a ZROADZ optional wiring harness kit (part# Z390020S-A) or by utilizing a compatible custom wiring harness. ZROADZ recommends LED Lights be wired with ZROADZ harness kit (part# Z390020S-A).

STEPS 18

ADJUSTMENT TIPS

21) To adjust the angle of your Light Bar, rotate the LED(s) to adjust the angles till your desired light pattern is reached. There will be minimal adjustment due to curved light bar orientation. You may then tighten the hardware and secure everything into place. Be careful not to over tighten the mounting hardware.

It is best to adjust the angle with the vehicle on level ground with lights facing a wall, garage door or other solid barrier. We recommend checking from a distance of 25'. Your installation is now completed.

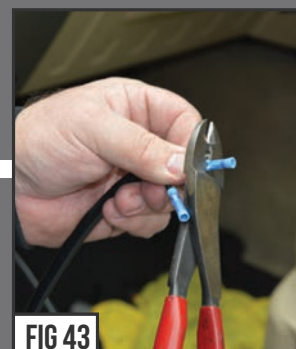

FIG 43

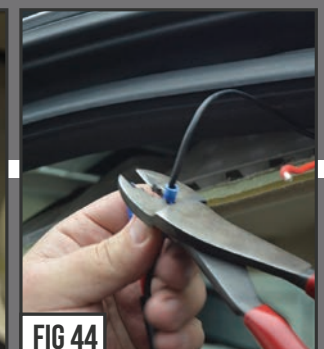

FIG 44

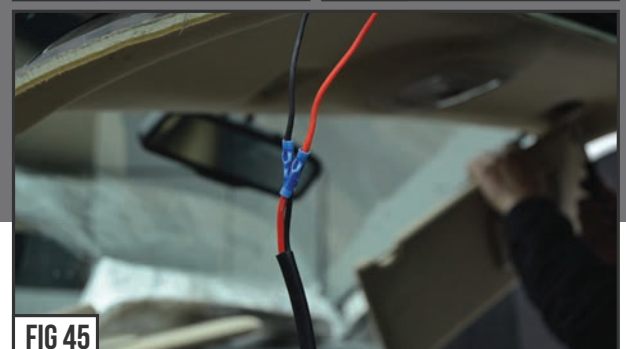

FIG 45

LED LIGHT ROOF MOUNT INSTALLATION - COMPLETE