



F5252 Installation Instructions 2017-2020 Ford Super Duty F250 / F350 1-3" Front Track Bar Bracket

Read and understand all instructions and warnings prior to installation of product and operation of vehicle.

Zone Offroad Products recommends this system be installed by a professional technician. In addition to these instructions, professional knowledge of disassembly/ reassembly procedures and post installation checks must be known. Minimum tool requirements include the following: Assorted metric and standard wrenches, hammer, hydraulic floor jack and a set of jack stands. See the "Special Tools Required" section for additional tools needed to complete this installation properly and safely.

» PRODUCT SAFETY WARNING

Certain Zone Suspension Products are intended to improve off-road performance. Modifying your vehicle for off-road use may result in the vehicle handling differently than a factory equipped vehicle. Extreme care must be used to prevent loss of control or vehicle rollover. Failure to drive your modified vehicle safely may result in serious injury or death. Zone Offroad Products does not recommend the combined use of suspension lifts, body lifts, or other lifting devices.

You should never operate your modified vehicle under the influence of alcohol or drugs. Always drive your modified vehicle at reduced speeds to ensure your ability to control your vehicle under all driving conditions. Always wear your seat belt.

Difficulty Level

easy ① 2 3 4 5 difficult

Estimated installation: 1-2 hours

Special Tools Required

Large Torque Wrench, able to torque to 405 ft-lbs

30mm Socket and Wrench

Tire/Wheel Fitment

N/A

» PRE-INSTALLATION NOTES

1. Special literature required: OE Service Manual for model/year of vehicle. Refer to manual for proper disassembly/reassembly procedures of OE and related components.
 2. Adhere to recommendations when replacement fasteners, retainers and keepers are called out in the OE manual.
 3. Larger rim and tire combinations may increase leverage on suspension, steering, and related components. When selecting combinations larger than OE, consider the additional stress you could be inducing on the OE and related components.
 4. Post suspension system vehicles may experience drive line vibrations. Angles may require tuning, slider on shaft may require replacement, shafts may need to be lengthened or trued, and U-joints may need to be replaced.
 5. Secure and properly block vehicle prior to installation of Zone Offroad Products. Always wear safety glasses when using power tools.
 6. If installation is to be performed without a hoist, Zone Offroad Products recommends rear alterations first.
 7. Due to payload options and initial ride height variances, the amount of lift is a base figure. Final ride height dimensions may vary in accordance to original vehicle attitude. Always measure the attitude prior to beginning installation.
-

***Important* Verify you have all of the kit components before beginning installation.**

F5252 Kit Contents

Qty	Part
1	Track Bar Bracket
2	Track Bar Cam Plates

Installation Instructions

1. Park the vehicle on a clean, flat surface and block the rear wheels for safety.
2. Disconnect the track bar from the driver's side frame bracket. Retain hardware.

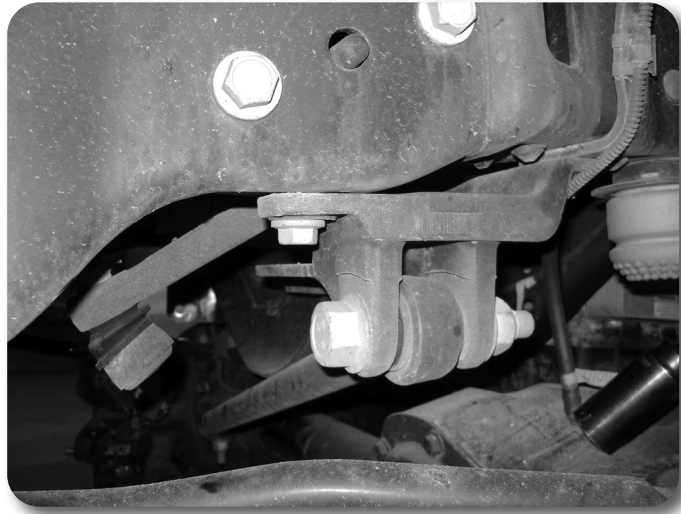

Figure 1

3. Remove the five bolts mounting the track bar bracket to the frame and remove the bracket from the vehicle.



Figure 2

4. Install the new bracket in the vehicle using the five original mounting holes and hardware. Torque mounting hardware to 129 ft-lbs.

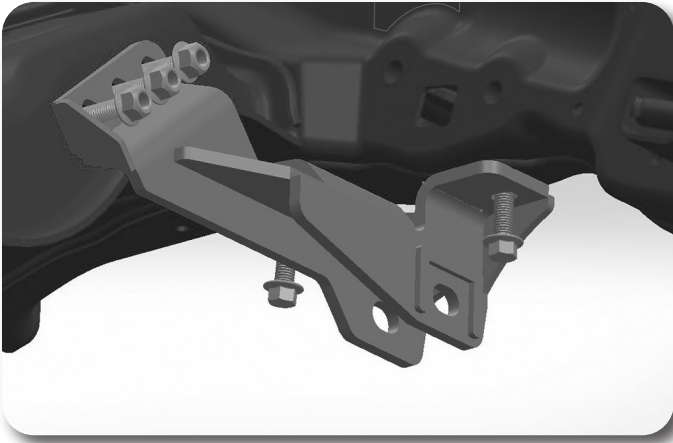

Figure 3

Post-Installation Warnings

1. Check all fasteners for proper torque. Check to ensure for adequate clearance between all rotating, mobile, fixed, and heated members. Verify clearance between exhaust and brake lines, fuel lines, fuel tank, floor boards and wiring harness. Check steering gear for clearance. Test and inspect brake system.

2. Perform steering sweep to ensure front brake hoses have adequate slack and do not contact any rotating, mobile or heated members. Inspect rear brake hoses at full extension for adequate slack. Failure to perform hose check/ replacement may result in component failure.

3. Perform head light check and adjustment.

4. Re-torque all fasteners after 500 miles. Always inspect fasteners and components during routine servicing.

5. Swing the track bar up into the bracket and attach with the original bolt and nut in conjunction with the provided rectangle cam washers.
Note: If installing on a vehicle with 3" of lift, offset the holes in the cams closer to the passenger's side. If installing on 2017-2019 Super Duty with 1-2" of lift, offset the holes in the cams closer to the passenger's side (Fig 4). If installing on 2005-2016 or 2020+ Super Duty with 1-2" of lift, offset the holes in the cams closer to the driver's side (Fig 4)

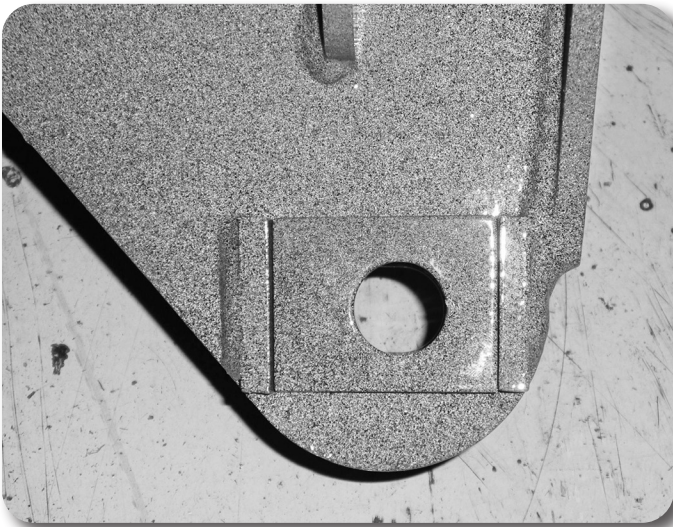

Figure 4 (Driver side installation Shown)

6. Torque the track bar mounting bolt to 405 ft-lbs.
7. Check all hardware for proper torque.
8. Check hardware after 500 miles.