

ELECTRIC COOLING FANS

ZF14S - 14 Inch High Performance Cooling Fan with S Blade

ZFX14S - 14 Inch Standard Cooling Fan with S Blade

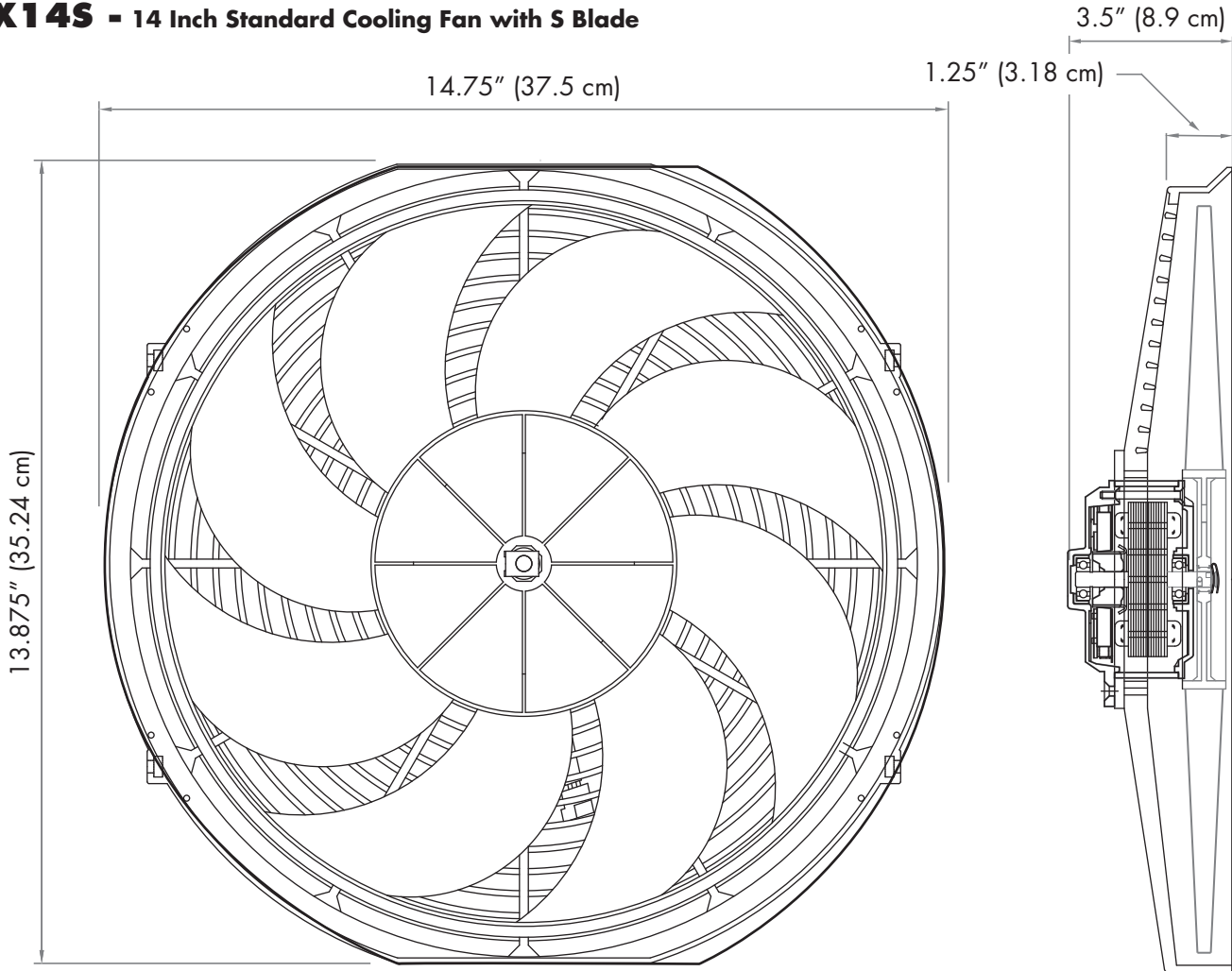

ZF14S	12 Volts	6.5±0.5A	96W	55W Output
ZFX14S	12 Volts	6.5±0.5A	96W	55W Output

CFM SPECIFICATIONS

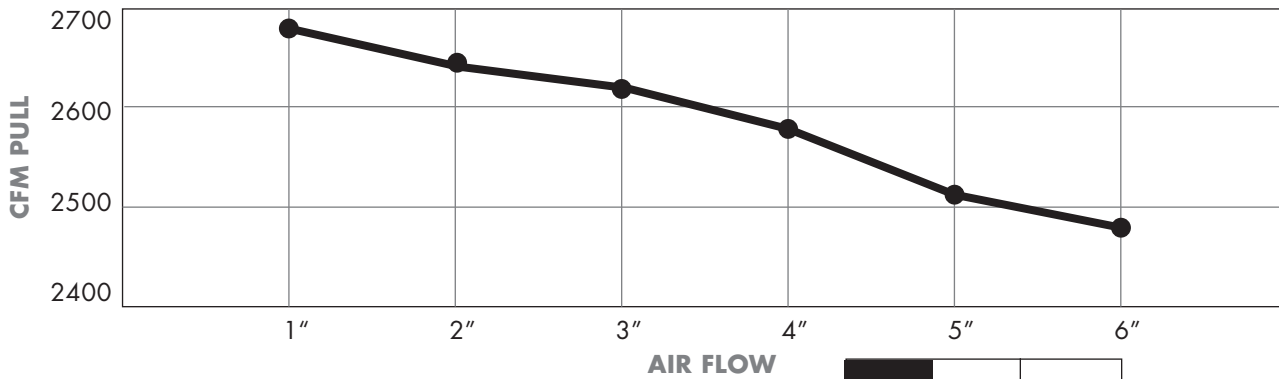

KEY	ZF14S	ZFX14S

Fan Relay Wiring Diagram

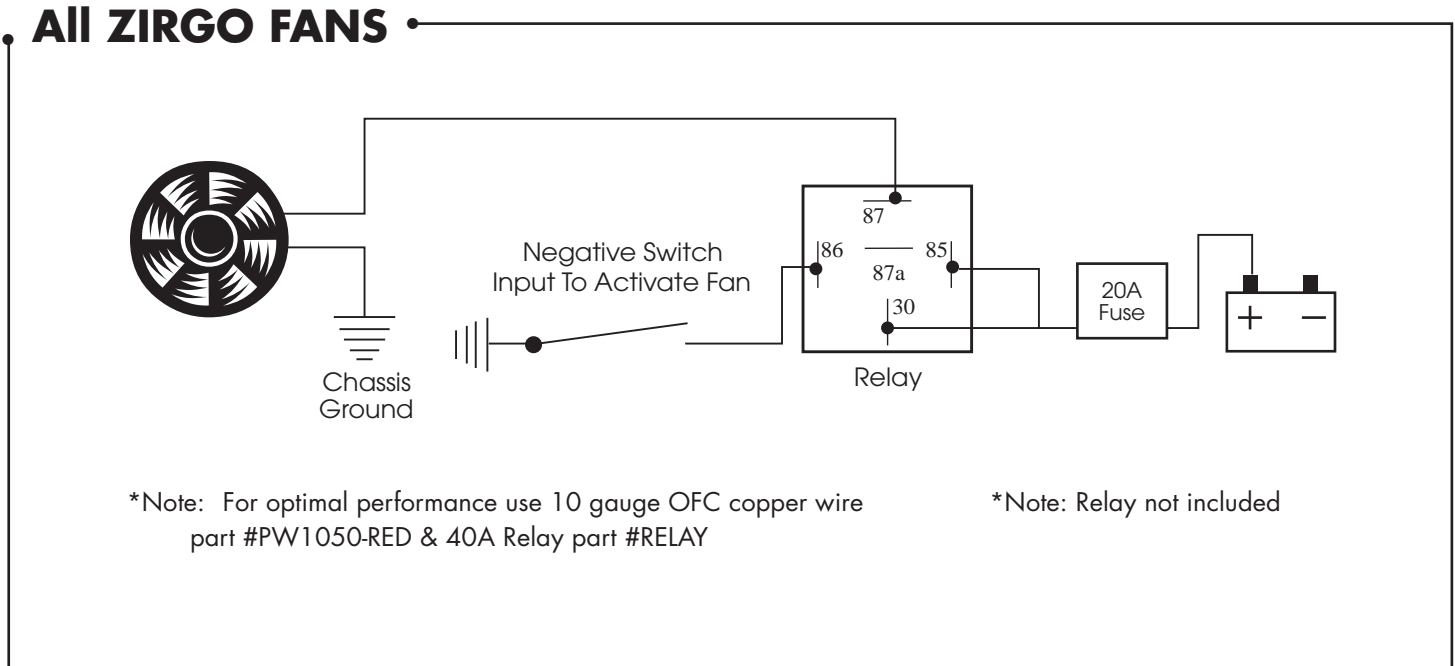

***NOTE: Zirgo Fans Are Designed and Shipped As Pullers.**

CHANGE FAN INTO PUSHER

1. Place the Fan on a table with the motor side down.
2. Remove the metal retaining clip (or bolt depending on model) from the top side of the fan.
3. Remove the fan blade. (figure 1)
4. Flip the fan blade over and reinstall it on the motor shaft.
5. Reinstall the metal retainer clip. (figure 1)
6. Reverse the polarity of the motor. Switch the black and blue wires on the motor making the BLACK 12V "+" AND BLUE Chassis Ground "-".

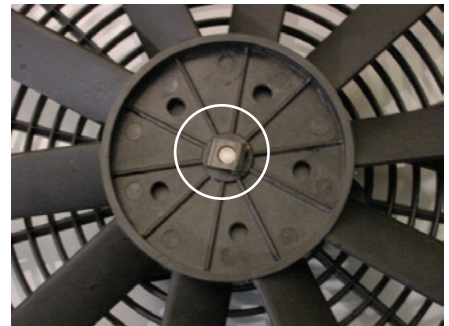

FIG. 1

PULLER WIRING

BLUE WIRE IS POSITIVE +
BLACK WIRE IS NEGATIVE -

PUSHER WIRING*

BLACK WIRE IS POSITIVE +
BLUE WIRE IS NEGATIVE -