



#82040 Perimeter Plate Nitrous System

Thank you for choosing ZEX™ products; we are proud to be your manufacturer of choice.



Why our nitrous system is better:

- Fits all popular square flange 4-barrel intake manifolds. Easy to install.
- Adjustable from 100-300 horsepower. Safe enough for stock engines, powerful enough for racing use.
- Injects at 12 unique points surrounding the intake manifold plenum. Eliminates 30 year-old technology spray bars and optimizes distribution of fuel and nitrous into the engine.
- Cryogenic design flows super-chilled nitrous through the entire plate, before being sprayed into the engine. This creates a cooling “deep freeze” effect on the carburetor and intake manifold for additional power.
- The perimeter injection plate is machined from solid billet aluminum. This ensures precision flow, unlike cast plates and old-technology spray bars the competition uses.

PARTS LIST

Description	Qty.	Description	Qty.
Nitrous Solenoid	1	.083 N20/ Fuel Jet	1
Fuel Solenoid	1	.088 N20/ Fuel Jet	1
12" SS Braid Hose -4AN, w/ -3AN & 1/8 NPT ends	2	.125 N20/ Fuel Jet	1
16' SS Braid Hose -4AN	1	Arming Switch	1
¼ NPT to -4 AN Filter Fitting	1	Throttle Activation Switch	1
¼ NPT to 3/8 NPT Hose Barb Fitting	1	Red 18 GA. Wire	15 ft.
10lb. Nitrous Bottle w/Valve	1	Red 14 GA. Wire	15 ft.
Bottle Bracket (short)	1	30amp Fuse Holder	1
Bottle Bracket (long)	1	30amp Fuse	1
Throttle Switch/Solenoid Bracket	3	Bosch 20amp Mini Relay	1
Perimeter Plate Assembly	1	Extended Carb Studs	4
Carb. Gasket	2	5/16 - 24 Carb Stud Nut	4
.043 N20/Fuel Jet	1	5/16-18 X 1" Bolt for Bottle Bracket	4
.046 N20/ Fuel Jet	1	5/16 - 18 Nut for Bottle Brackets	4
.053 N20/ Fuel Jet	1	5/16 Flat Washers	8
.062 N20/ Fuel Jet	1	Solenoid Bracket Screws	4
.064 N20/ Fuel Jet	1	4-40 X 5/8 Socket Head Cap Screw	2
.072 N20/ Fuel Jet	1	4-40 Nylon Insert Lock-Nut	2
.074 N20/ Fuel Jet	1		

Quick Start Reference Guide:

- **How the ZEX™ Perimeter Plate Nitrous System works:** The ZEX™ Part #82040 nitrous system begins with a connection to a supply cylinder containing pressurized liquid nitrous oxide and a connection to the engine's fuel system. These connections go to the system's nitrous and fuel solenoids, respectively. These solenoids are normally closed but are opened when the nitrous system is armed, and the throttle switch is activated by the carburetor going to wide-open throttle. Once these solenoids open, the nitrous and fuel are delivered to the injection plate via braided stainless steel delivery lines. The amount of nitrous and fuel that is injected through the plate is adjustable by means of metering jets installed in the plate itself. These metering jets allow for easy changes in horsepower settings.
- **What is nitrous oxide?** Nitrous oxide is a gas composed of two nitrogen atoms bonded to one oxygen atom. The scientific abbreviation for one nitrous oxide molecule is N₂O, where N is nitrogen and O is oxygen. This is where the familiar phrase "N-2-0" comes from when people talk about nitrous oxide.
- **How nitrous oxide makes power:** Nitrous oxide kits make large amounts of horsepower by allowing an engine to burn more fuel. Burning more fuel creates higher cylinder pressures that will push down on the piston with greater force. When the nitrous is injected into an engine and the initial combustion takes place, it creates enough heat to separate the nitrous oxide into its

two components, nitrogen and oxygen. Once separated, the additional oxygen is then free to react with additional fuel. To run nitrous successfully and safely, you have to introduce precise amounts of additional fuel with precise amounts of nitrous oxide. All of the extra oxygen provided by the nitrous oxide must have fuel to react, or you may damage your engine severely.

- **All the power comes from the fuel, not the nitrous.** Nitrous oxide is a simple tool that allows you to adjust how much and how quickly the engine burns the fuel. If the fuel isn't there, the power won't be either.
- **Avoid detonation at all times.** Nitrous oxide enhanced detonation is much more damaging than detonation that occurs when naturally aspirated. This is due to the increased amount of fuel available for releasing energy and the fact that more oxygen is present.
- **If, when your system is activated, something doesn't feel or sound right, BACKOFF!** If you hear any detonation or feel anything unusual, get off the throttle. It's a lot easier to check everything over than it is to just try to drive through it and damage expensive parts.
- **Work safely.** Always wear eye protection and gloves when working with lines or hoses that contain pressurized nitrous oxide or fuel. Never transport nitrous cylinders loose in a trunk or the bed of a pick-up truck and especially **NOT** within a vehicle's interior whether the cylinder is empty or full. Always disconnect the ground side of the battery when working any electrical components.
- **Nitrous oxide will not fix problems you already have.** Before you install your nitrous system, be sure your engine is in good mechanical condition. Intermittent wiring problems, etc., can lead to erratic system performance and possible engine damage.
- **Never defeat the operation of the safety relief disc in the nitrous cylinder's valve stem.** It's required by law and is there for your safety. Never drill, machine, weld, deform, scratch, drop, or modify a nitrous oxide cylinder in **ANY** way whatsoever!
- **Never overfill nitrous cylinders.** That little bit extra will put you and others at risk of injury. More often than not, when the cylinder warms up, the pressure goes above the limit of the safety relief disc, and you lose all the nitrous you just paid for.
- **Do not use Teflon sealing tape on any fittings in a ZEX™ nitrous system.** It is easy for Teflon tape to get pulled into the system, causing blockages that can ultimately lead to incorrect nitrous system performance and potentially, engine damage. Only use liquid thread sealer for all NPT type fittings. Do not use any thread sealing compound on AN style fittings.
- **Do not attempt to start your engine if nitrous has been accidentally injected into the engine while it was not running.** Disable the ignition and, with the throttle wide open, turn over the engine for several seconds to clear the nitrous from the engine. Failure to do this before restarting the engine can lead to a dangerous intake system backfire.

- **Do not engage your nitrous system below 2500 rpm.** This ensures that you will not have excessive cylinder pressures that could cause engine damage.
- **Do not run excessive bottle pressures.** Excessive bottle pressures over 1100psi are dangerous to your engine. Your ZEX™ nitrous system is calibrated and optimized to operate from 900-1000psi. Exceeding this will not improve performance. Over 1100psi also runs the danger of locking the nitrous solenoid closed due to excessive pressure working against the valve's plunger. If this happens, you must cool the nitrous bottle down to lower the pressure. This will allow the valve to operate properly.
- **Clear nitrous lines after use.** Close bottle valve. Use purge kit to relieve pressure or open line fitting to let nitrous bleed off.
- **When finished using your nitrous system, close the nitrous bottle valve and relieve the line pressure.** This eliminates the possibility that nitrous could inadvertently accumulate in the intake manifold while the nitrous system is not being used.
- **Start with the lowest horsepower setting and work your way up.** This ensures if you have any tuning issues to work out on your vehicle, they will get sorted out with a smaller shot of nitrous that will be less likely to damage your engine. Once you have the car working well on the smaller shot, you can then safely start to step up your nitrous kit horsepower.
- **Make sure your vehicle has an adequate fuel supply.** Nitrous systems put a large demand on your vehicle's fuel system. Make sure you have a large enough fuel pump to handle the demands of your engine, as well as the nitrous system.
- **Spark plugs and nitrous performance:** Quite often, factory type, wide gap, projected nose spark plugs will produce a detonation condition after a few seconds of nitrous use. The solution to the problem is to install spark plugs that have a colder heat range and proper ground strap design for nitrous use. Consult your preferred spark plug manufacturer to ensure you install the correct plugs for the nitrous level you choose to run.
- **How to adjust power levels.** The ZEX™ Perimeter Plate Nitrous System is designed for multiple power levels. These levels are controlled by metering jets installed in the plate's fuel and nitrous jet fittings. To change the power output, all you need to do is install the appropriate set of jets as shown in Fig. 1. The correct combination of jets is listed on the tune-up sheet on the back of this instruction manual.

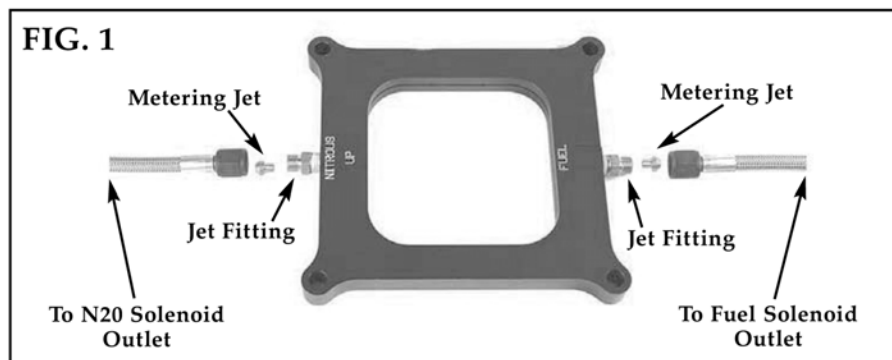

Installation Instructions:

- 1. Decide where to put everything** - Before you start to install the various components of this kit, you'll have to locate the best locations of each component by trial fitment and careful measurement. First, decide where you want to mount the nitrous and fuel solenoids. Remember, the stainless steel braided lines that connect these to the injection plate are 12 inches long. You'll also have to decide where to install the arming switch and the nitrous bottle. The arming switch should be installed in a position convenient to the driver, but not in an area that would increase the chances of unintentionally arming the system. To help you decide where and how you'll mount the nitrous supply bottle, check Fig. 2, 3, 4, and 5 for technical restrictions on bottle mounting locations and positions. Finally, have a reputable performance shop fill your nitrous bottle with automotive grade nitrous oxide before you begin. Do not overfill the nitrous bottle.

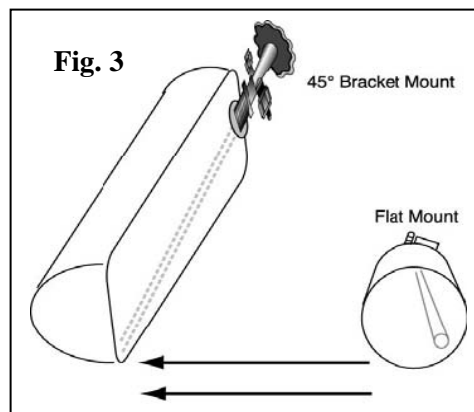
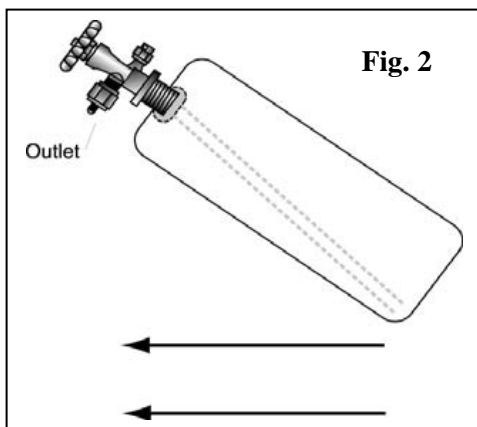

- 2. Mount nitrous supply bottle** - Mount the nitrous supply bottle so that it is separated from the passenger cabin. Fastback style cars that do not have a separate trunk compartments have to be equipped with a safety blowdown tube (Fig. 5). Route the tube from the safety pressure relief cap to the exterior of the car, preferable under the car. Doing so will prevent your car from filling with a cloud of nitrous oxide should the safety pressure relief cap rupture. Always mount the bottle so that as your car accelerates, the liquid flows towards the pick-up tube. ZEX™ nitrous bottles are designed with the bottom of the siphon tube at the bottom of the bottle towards the outlet.

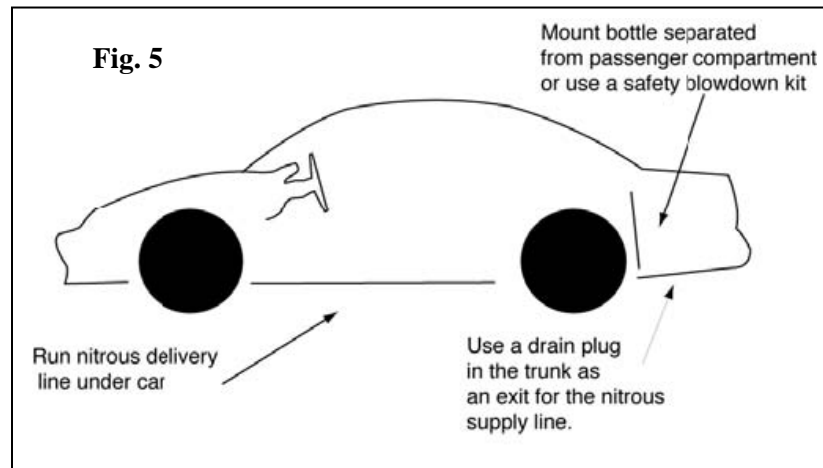

- 3. Mount nitrous delivery line under the car** - When routing the nitrous delivery line under the car, try to use the subframe as a conduit (Fig. 5). This protects the line and eliminates the need to use clamps. The supplied cable ties work if you can run the line higher in the under-body so that it's safe from the road level obstacles such as speed bumps. For the pro-race look, you can use steel loom clamps with rubber sheathing to fasten the line to the body.
- 4. Install injector plate.**
- A. Remove the air cleaner.
 - B. Disconnect the throttle linkage.
 - C. Disconnect the fuel line. Be sure to avoid spilling fuel on the engine.
 - D. Remove the carburetor and old carb gasket, taking special note of all vacuum lines and choke linkages. Place a rag over the opening of the intake manifold to ensure that no debris or loose components get accidentally dropped into the engine during installation.
 - E. Remove the original carb studs, and install the extended studs that are included with the nitrous kit.
 - F. Place one of the carb gaskets that are supplied with the nitrous kit on the manifold's carb flange. Place the nitrous injector plate on top of it, ensuring it is right side up. Place the other carb. gasket on top of the plate.
 - G. Assemble the 12" long, -4AN hose assembly, with the purple anodized nut, to the outlet of the nitrous solenoid. Install one of the -4AN filter fittings into the inlet of the nitrous solenoid. Install one of the solenoid brackets to the bottom of the solenoid using the button head Allen screws included in the kit (see Fig. 6).



- H.** Select the appropriate nitrous jet to be used for the desired horsepower level and insert it into the nitrous jet fitting in the end of the injector plate. Attach the hose that is connected to the nitrous solenoid to the jet fitting (see Fig. 1). Using a backing wrench, tighten the hose to the jet fitting.
- I.** Remove one of the intake manifold bolts and use it to fasten the solenoid bracket to the engine.
- J.** Attach the nitrous delivery line, from the bottle, to the nitrous solenoid. Assemble the 12" long, -4AN hose assembly, with the red anodized nut, to the outlet on the fuel solenoid. Install one of the solenoid brackets to the bottom of the solenoid using the button head Allen screws included in the kit (see Fig.7).
- K.** Select the appropriate fuel jet to be used for the desired horsepower level and insert it into the fuel jet fitting in the end of the injector plate. Attach the hose that is connected to the fuel solenoid to the jet fitting (see Fig. 1). Using a backing wrench, tighten the hose to the jet fitting.
- L.** Remove one of the intake manifold bolts and use it to fasten the solenoid bracket to the engine.
- M.** Connect the fuel solenoid inlet to a filtered source of pressurized fuel. 6psi of flowing fuel pressure is required at the inlet of the fuel solenoid for a correct and safe tune-up. A 3/8 hose barb fitting is provided for connection purposes, if needed.
- N.** Reinstall the carburetor, vacuum lines, and choke linkages.

5. Wiring

- A.** Mount the arming switch in an easily accessible area for the driver.
- B.** Assemble the throttle switch to the throttle switch bracket using the 4-40 bolts and nylon lock nuts (see Fig. 8). Do not over-tighten the bolts as damage to the throttle switch can result.

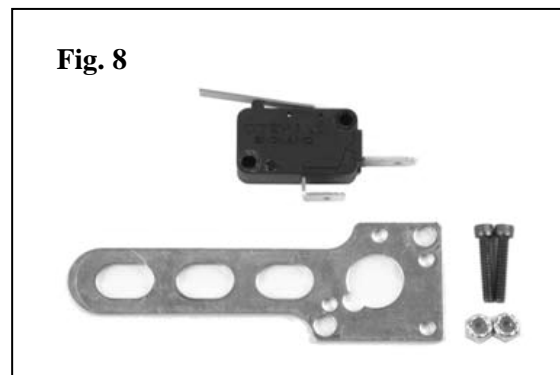

- C.** The throttle switch bracket is made of easily formed material. Attach the end of the bracket to one of the carb studs and bend the bracket in such a way to allow the carburetor's throttle arm to contact and depress the switch arm at wide open throttle.
- D.** Using the supplied electrical connectors and wire, refer to the wiring diagram for proper routing and electrical connections for the nitrous system (see Fig. 9). Always use the supplied fuse for electrical system protection in the event of a short in the system. The best positive (+) power source for the nitrous system is a direct connection to the battery's positive (+) post. Do not splice into the factory wire harness, it will not have the ability to supply the current required by the nitrous and fuel solenoids.

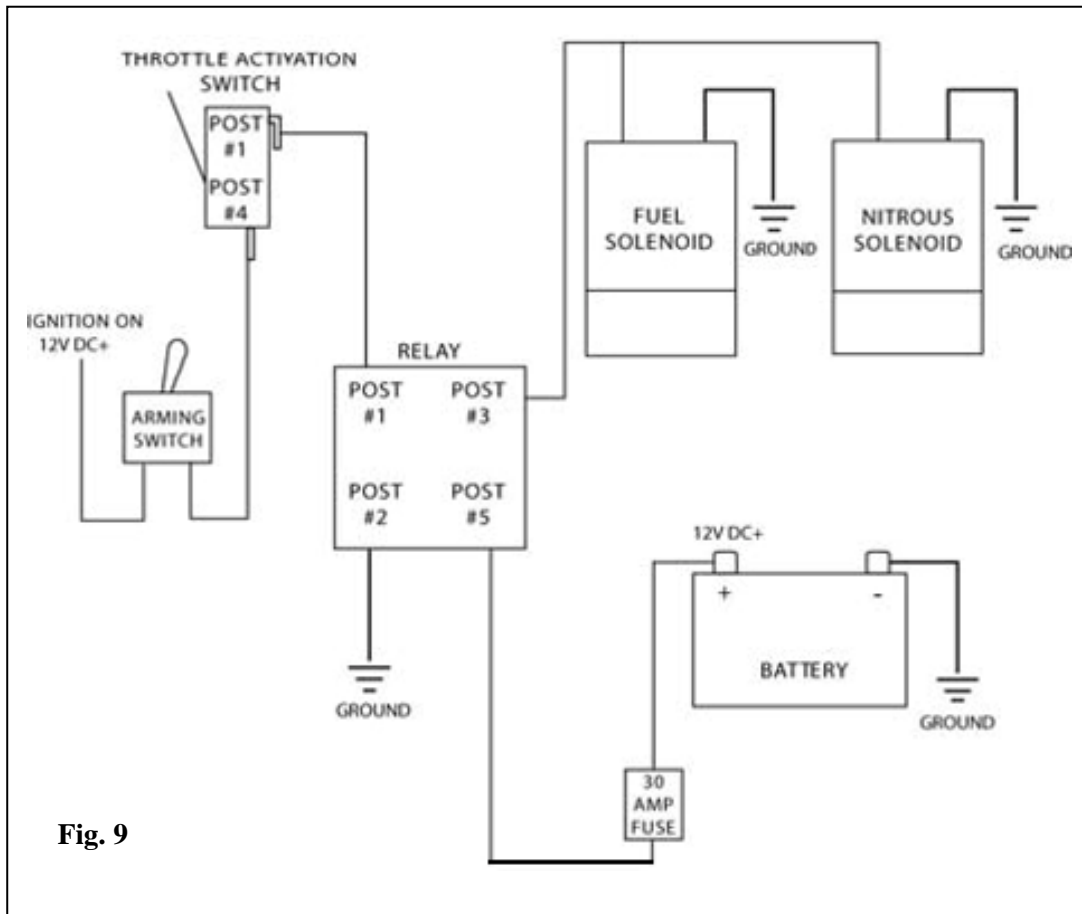

Fig. 9

6. Check fuel and nitrous pressure lines.

- A. Perform a final inspection of all plumbing and electrical connections to ensure that they are correct.
- B. Turn the arming switch to the ON position.
- C. Depress the throttle switch and listen for both solenoids to click. If they both do not click, locate the problem and correct it before proceeding.
- D. Start the engine and observe all fuel connections for any leaks. Fix any fuel leaks before proceeding.
- E. Adjust the fuel pressure going to the inlet of the nitrous system's fuel solenoid to 6 psi flowing. Make sure you use a flowing fuel pressure tool to set the fuel pressure. Setting a "dead-head" style regulator in a non-flowing condition will not give you an accurate fuel pressure setting. Severe engine damage can occur if care is not taken to ensure the correct fuel pressure at the solenoid.
- F. Turn off engine.
- G. Open nitrous bottle valve. Listen carefully for any leaks as your valve is opened. Leaks in the nitrous supply line will be obvious because they will be covered in frost.
- H. If everything checks out, close the nitrous bottle valve and relieve the pressure.

7. Reinstall your air cleaner.

- 8. Check fuel quality & ignition timing.** The last two things to check before enjoying your new ZEX™ nitrous system are the fuel quality and ignition timing. First, the correct fuel is in the fuel tank. Premium fuel for 100-150 and race fuel for 200-300 will ensure the maximum safety and detonation resistance for your engine. Second, make sure the ignition timing is set correctly. All recommended ignition timing retard amounts on the Tune-Up Sheet are calculated off of the base, ignition setting. It is important to set this with a timing light before you use your nitrous system for the first time. Do not assume that it is set properly. If the ignition timing is not set correctly, severe engine damage may occur.

ZEX #82040 Nitrous System Tune-Up Sheet

	100hp	150hp	200hp	250hp	300hp
Nitrous Jet (950psi)	46	62	74	88	125
Fuel Jet (6psi)	43	53	64	72	83
Ignition Retard	4°	6°	8°	10°	12°

For engines less than 10:1 compression ratio, using nitrous system settings of 150 hp or less, pump premium fuel is required for safe operation of your ZEX™ Nitrous System. For engines with 10:1 compression or greater, using nitrous system settings higher than 150 hp, high octane racing fuel is required for safe operation of your ZEX™ nitrous system. Nitrous fuel system pressure must be set at 6psi, flowing, at the inlet of the fuel solenoid.