

YAKIMA KingJoe Pro 2/3

KingJoe Pro (1x)

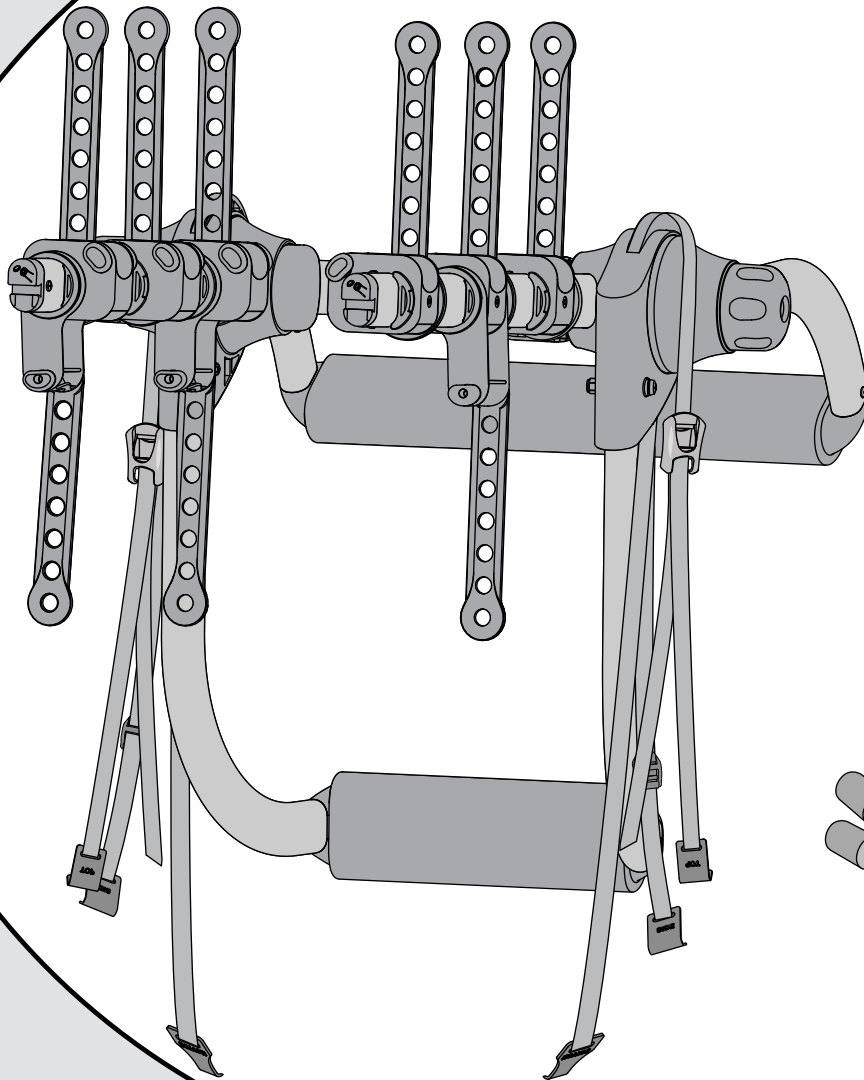

Wheel Strap (1x)

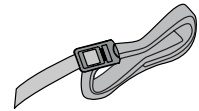

Long Strap (1x)

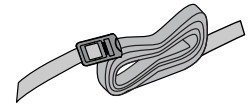

Glass Hatch Adapter (2x)

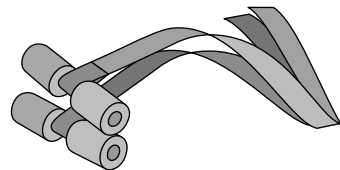

IMPORTANT WARNING

IT IS CRITICAL THAT ALL YAKIMA RACKS AND ACCESSORIES BE PROPERLY AND SECURELY ATTACHED TO YOUR VEHICLE. IMPROPER ATTACHMENT COULD RESULT IN AN AUTOMOBILE ACCIDENT, AND COULD CAUSE SERIOUS BODILY INJURY OR DEATH TO YOU OR TO OTHERS. YOU ARE RESPONSIBLE FOR SECURING THE RACKS AND ACCESSORIES TO YOUR CAR, CHECKING THE ATTACHMENTS PRIOR TO USE, AND PERIODICALLY INSPECTING THE PRODUCTS FOR ADJUSTMENT, WEAR, AND DAMAGE. THEREFORE, YOU MUST READ AND UNDERSTAND ALL OF THE INSTRUCTIONS AND CAUTIONS SUPPLIED WITH YOUR YAKIMA PRODUCT PRIOR TO INSTALLATION OR USE. IF YOU DO NOT UNDERSTAND ALL OF THE INSTRUCTIONS AND CAUTIONS, OR IF YOU HAVE NO MECHANICAL EXPERIENCE AND ARE NOT THOROUGHLY FAMILIAR WITH THE INSTALLATION PROCEDURES, YOU SHOULD HAVE THE PRODUCT INSTALLED BY A PROFESSIONAL INSTALLER.

Part #1033584 Rev.A

1 Set your vehicle specific measurement.

Refer to the Fit Guide on the product carton to find the measurement for your specific vehicle. With both side knobs loosened set the distance between rivets to the measurement for your vehicle, and then tighten both knobs completely. Be sure that the knobs have engaged fully.

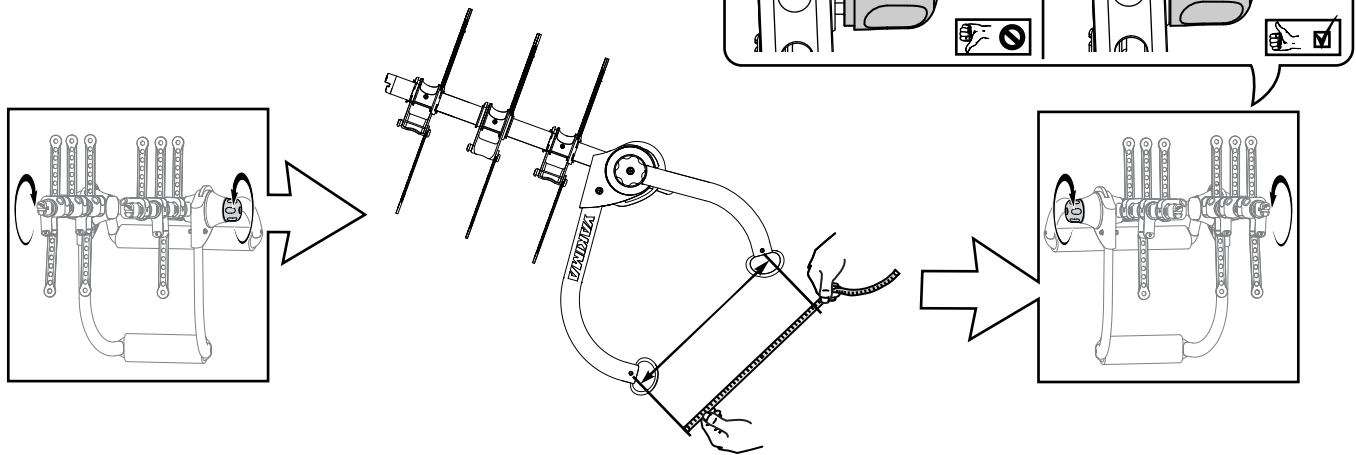

2 Position KingJoe Pro on vehicle.

PLACEMENT WILL VARY DEPENDING ON VEHICLE.

Upper Frame:

- The position is relative to the lower frame and will depend on vehicle shape.

Lower Frame:

- **LOWER SUPPORT FRAME LOCATION IS EXTREMELY IMPORTANT TO THE LOAD!**
- A common location is a well supported license plate depression, just above or below the numbers.
- **Use area with the greatest support.**
- Do not place the lower frame on glass, plastic, or thin metal.
- Some SUV's, vans, and wagons have a large section of poorly supported metal that will dent under weight.



Clean the contact points on the vehicle, and keep the pads free of debris.

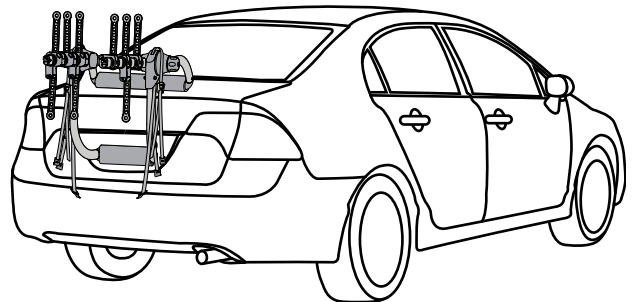
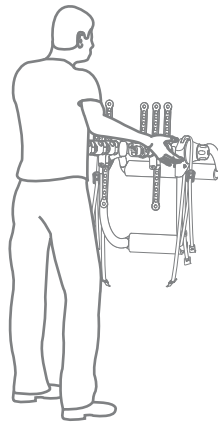

- **Some bumpers and body panels can deform or "tin-can". Do not place in these areas. This can result in vehicle damage, or an insecure fit.**
- **Do not place KingJoe Pro on vehicle's emblem.**

3 Attach top hooks.

Attach both top strap hooks (labeled TOP) around top edge of the trunk lid, hatch lid, or rear door.

They should be parallel, and no wider than the body of the KingJoe Pro. Route the straps over the KingJoe Pro frame. If hooks do not fit into the edge of the hatch or trunk, you can install the Glass Hatch Hooks.

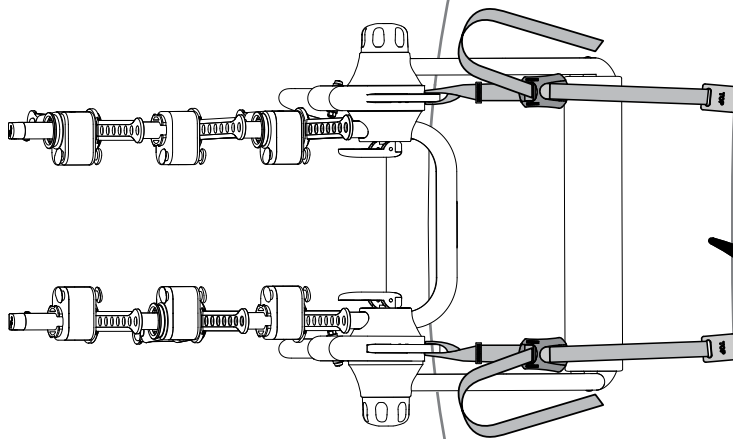

Remove hooks before opening the hatch or trunk. Opening the hatch or trunk with hooks installed could cause damage to the vehicle.

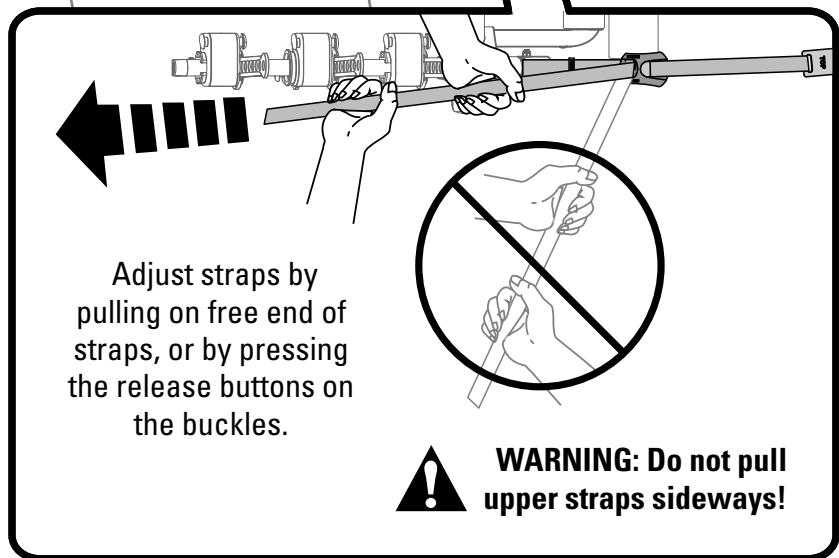

Adjust straps by pulling on free end of straps, or by pressing the release buttons on the buckles.



WARNING: Do not pull upper straps sideways!



WARNING: DO NOT ATTACH THE UPPER HOOKS TO GLASS, PLASTIC, OR SPOILERS! USE THE GLASS HATCH ADAPTERS. USE OF THE GLASS HATCH ADAPTERS WILL LIMIT THE LOAD TO TWO BIKES ONLY.

Follow Glass Hatch Adapter installation instructions on page 5.

4 Attach bottom hooks.

Attach both bottom strap hooks (labeled BOTTOM). Appropriate attachment points will depend on your specific vehicle.

Acceptable attachment points may include the bottom edge of the trunk, hatch lid, or rear door. Or the tie down hooks underneath the vehicle. Or the metal ledge of the bumper. Only attach hooks to areas with sufficient support.



Route the straps over the KingJoe Frame frame as shown.

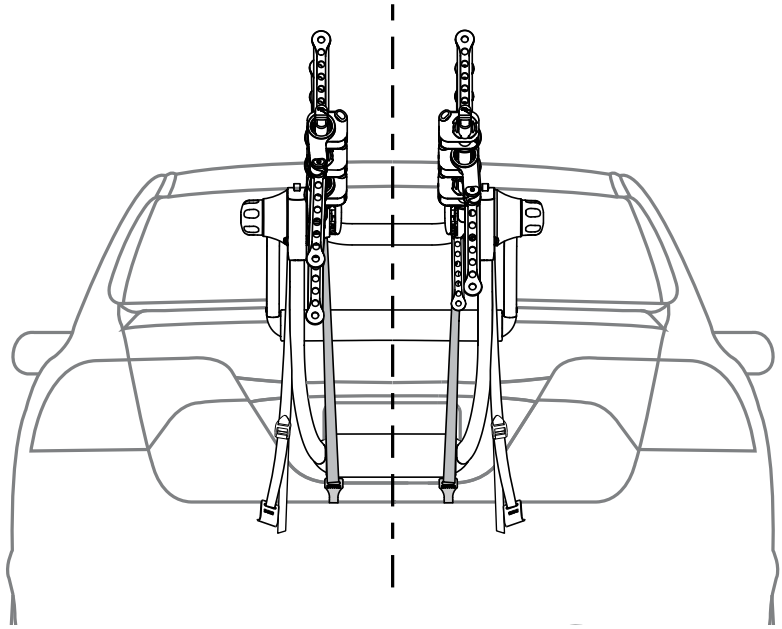

WARNING: DO NOT ATTACH THE LOWER HOOKS TO GLASS, OR PLASTIC! USE THE GLASS HATCH ADAPTERS. USE OF THE GLASS HATCH ADAPTERS WILL LIMIT THE LOAD TO TWO BIKES ONLY.

Follow Glass Hatch Adapter installation instructions on page 6.

5 Attach side hooks.

Adjust straps as necessary to attach side strap hooks (labeled SIDE) to upper side edge of trunk, hatch, rear door, or above, below, or next to the tail lights. Adjust straps by pulling on free end of straps.

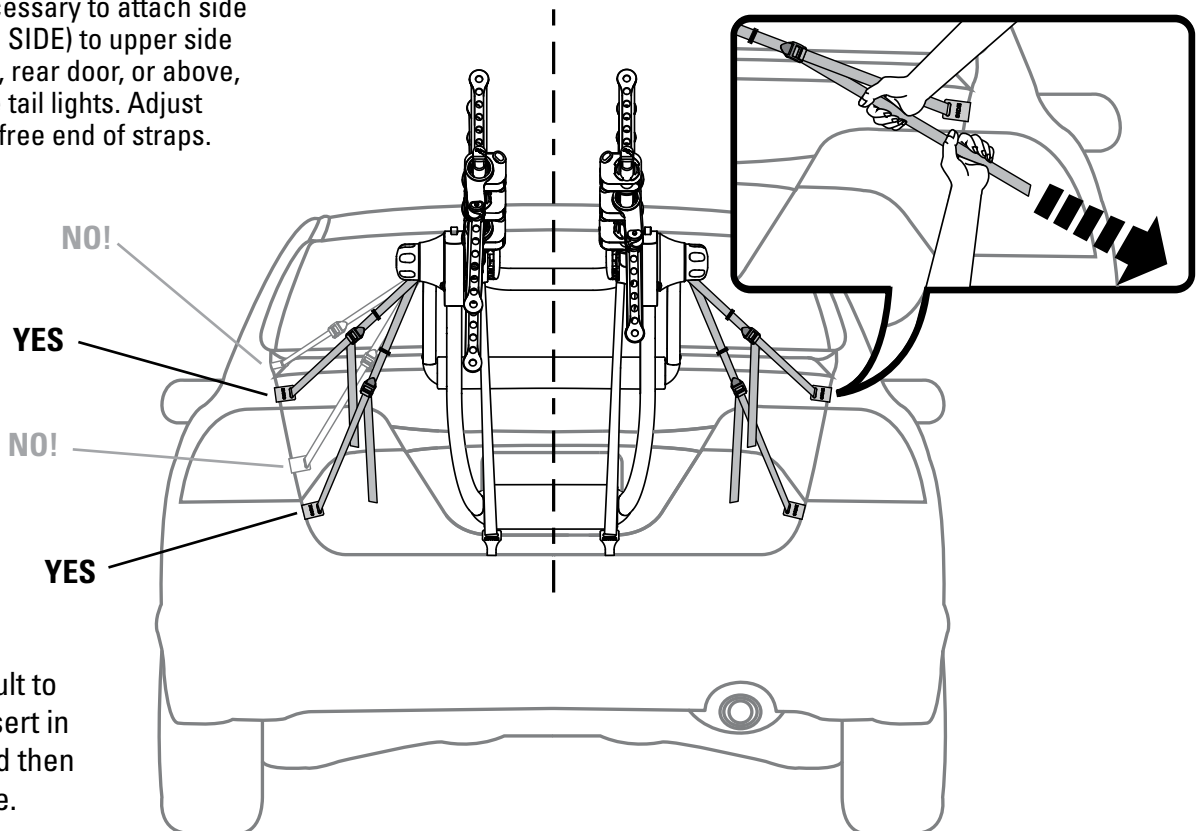

Note: If it is difficult to get the hook in, insert in a wider section and then slide into place.

6 TIGHTEN ALL STRAPS COMPLETELY. DO NOT OVERTIGHTEN.

TOP HOOKS: Glass Hatch Adapter installation instructions



No glass or plastic? You won't need the Glass Hatch Adapters. Skip this page.

A

Remove the upper top strap and top hooks.

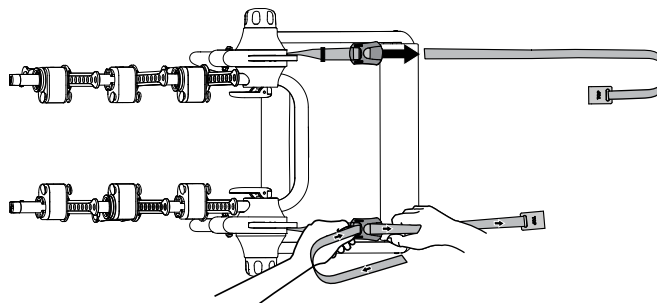

B

OPEN THE HATCH DOOR.

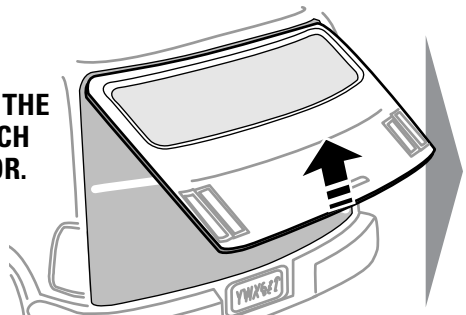

Pass the Glass Hatch Adapter strap ends through the hatch opening from inside the vehicle.



Keep the pads away from the door's edge.

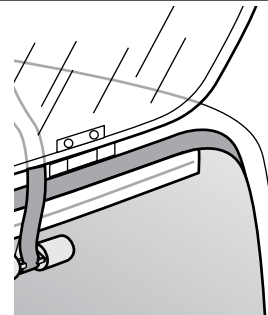

C

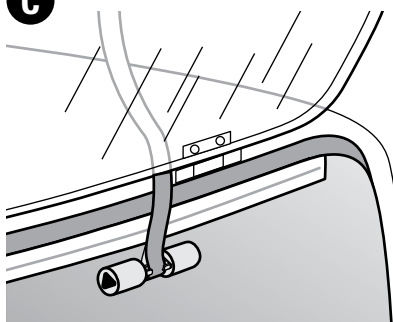

BEFORE CLOSING THE HATCH...

The pads must be free from contact between hatch door and vehicle's frame.

Straps should be parallel with the top buckles.

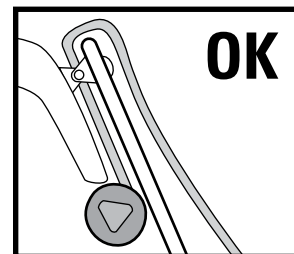
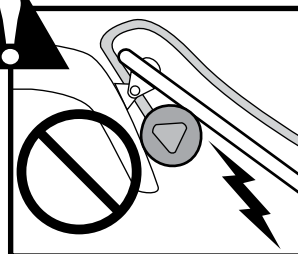

D

CLOSE THE HATCH.

Pull firmly on the straps to seat the pads.

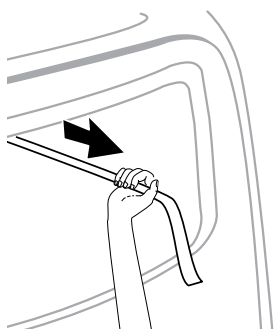

E

THREAD NEW STRAP-ENDS INTO KINGJOE PRO BUCKLES.

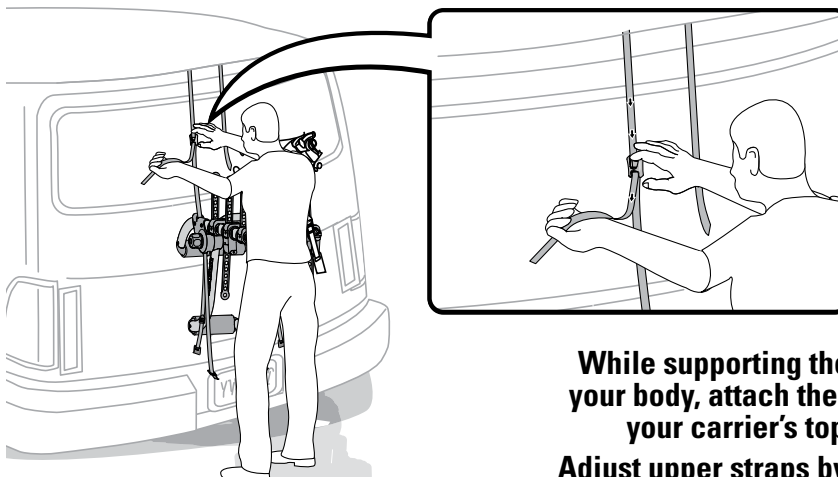

While supporting the carrier with your body, attach the new straps to your carrier's top buckles.

Adjust upper straps by pulling on the ends **TOWARD THE VEHICLE.**

Now that you've installed the glass hatch adapters continue to **STEP 4.**

BOTTOM HOOKS: Glass Hatch Adapter installation instructions



No glass or plastic? You won't need the Glass Hatch Adapters. Skip this page.

A

REMOVE THE CARRIER FROM THE CAR.

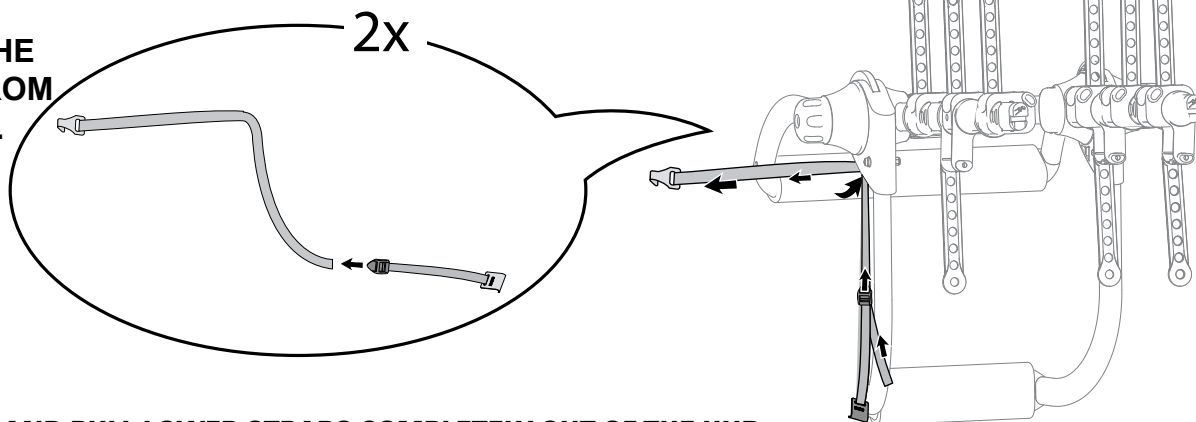

UNBUCKLE AND PULL LOWER STRAPS COMPLETELY OUT OF THE HUB.

B

OPEN THE TRUNK DOOR.

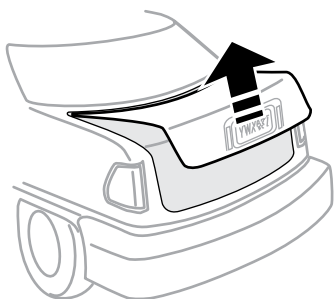

C

Position the pads inside the trunk with the straps hanging free.

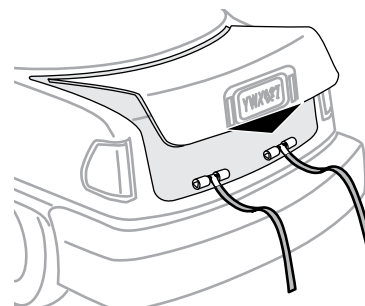

D

BEFORE CLOSING THE TRUNK:

Be sure the pads are free from contact between trunk door and vehicle's frame.

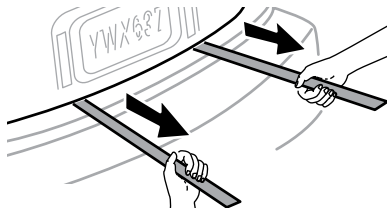

- CLOSE THE TRUNK.
- Pull firmly on the straps to seat the pads.

E

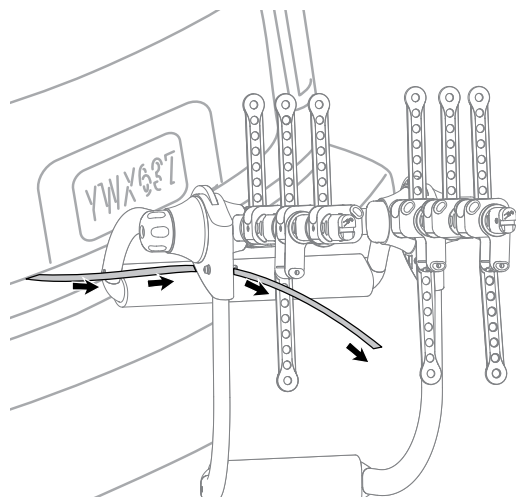

Insert new strap through hub as shown. Thread new strap back through buckle to re-attach side hooks.

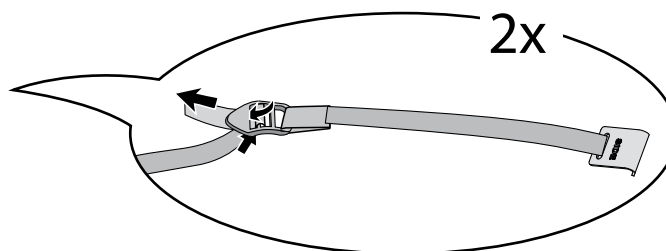

Now that you've installed the bottom glass hatch adapters continue to STEP 5.

7 Secure loose strap ends.

Secure all loose strap ends by bundling them together and tucking them into the flexible bands located on the straps.

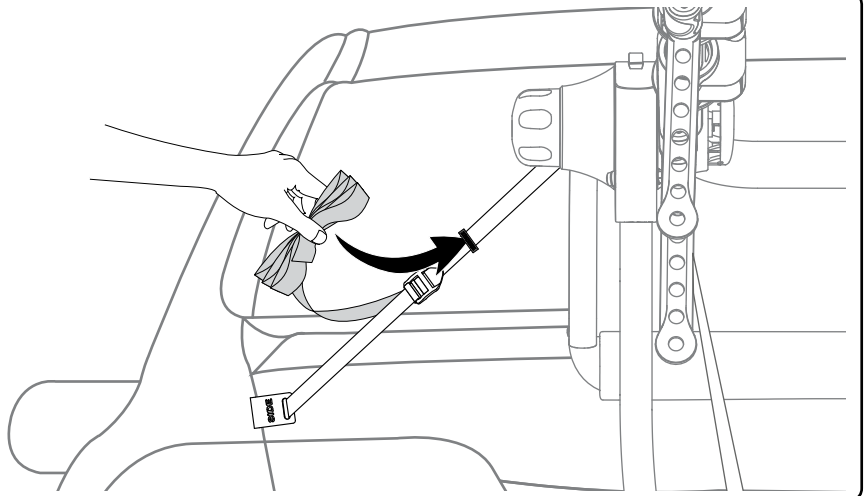

8 Raise support arms.

Open the support arm levers and adjust the support arm so that it angles upward as show. Close support arm levers.



Pull downward on both support arms to ensure they are locked into position.

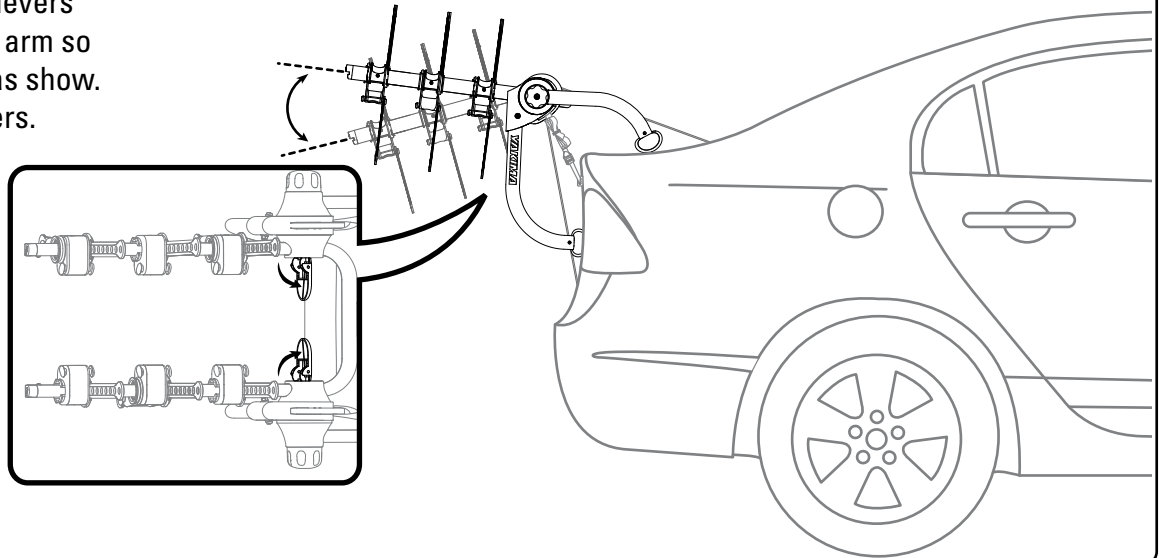

9 Load bike(s).

- Rotate anti-sway cradles out of the way for easier loading.
- Load heaviest bike first.
- Always load first bike with chain away from vehicle.
- Load Bikes starting in spots closest to the vehicle.
- Use Wheel Strap to secure bike's front wheel to its frame.

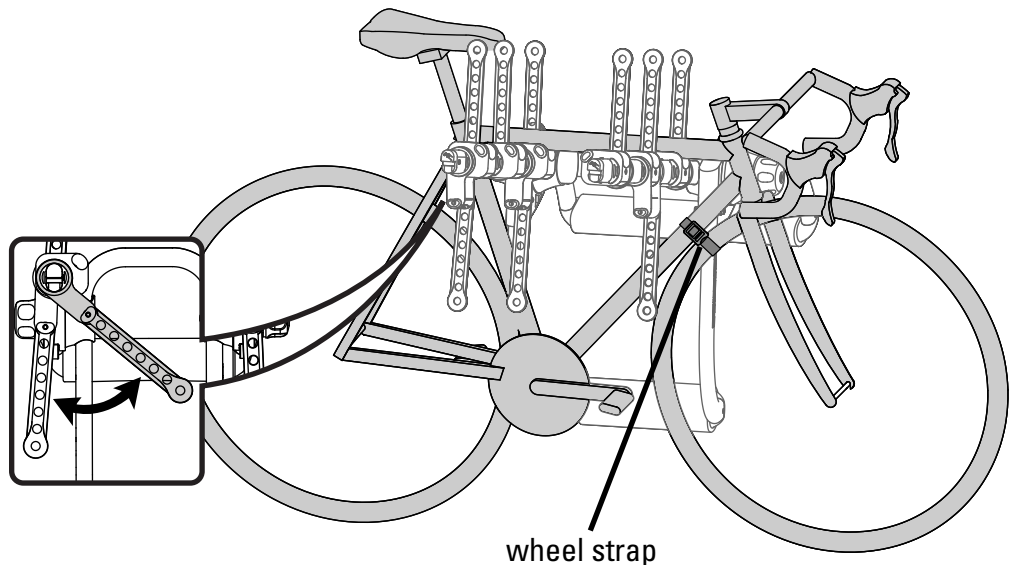

Alternate bike directions to avoid interference.

10 Attach rubber straps.

- Move the stabilizing cradle against the seat tube.
- Pull Rubber Straps tight over frame and hook into place.
- **BE SURE RUBBER STRAPS ARE FULLY ENGAGED!**

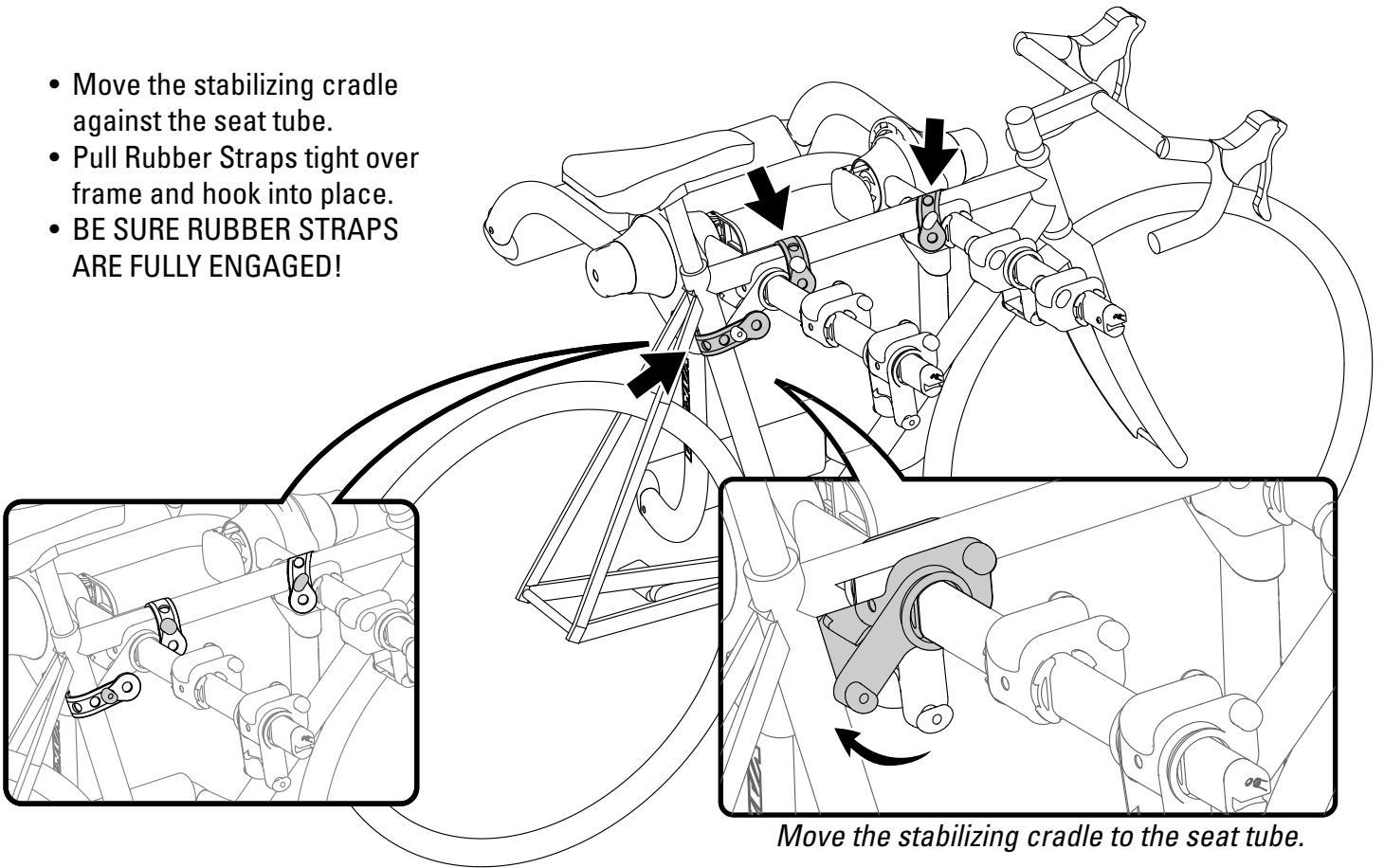

11 Install long strap.

- Use long strap to secure bike frames to KingJoe Pro frame.
- Secure loose strap end.

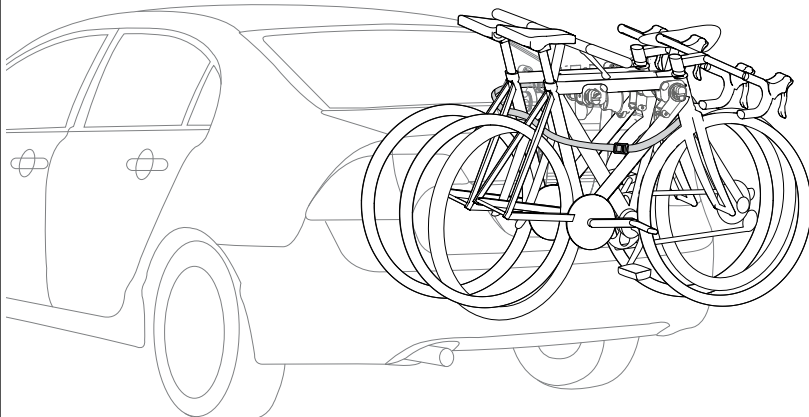

Bottle Opener

Now that you've installed your Yakima KingJoe Pro take a moment to enjoy the beverage of your choice.

Use the built in bottle openers to crack open a cold one!

