

# YAKIMA

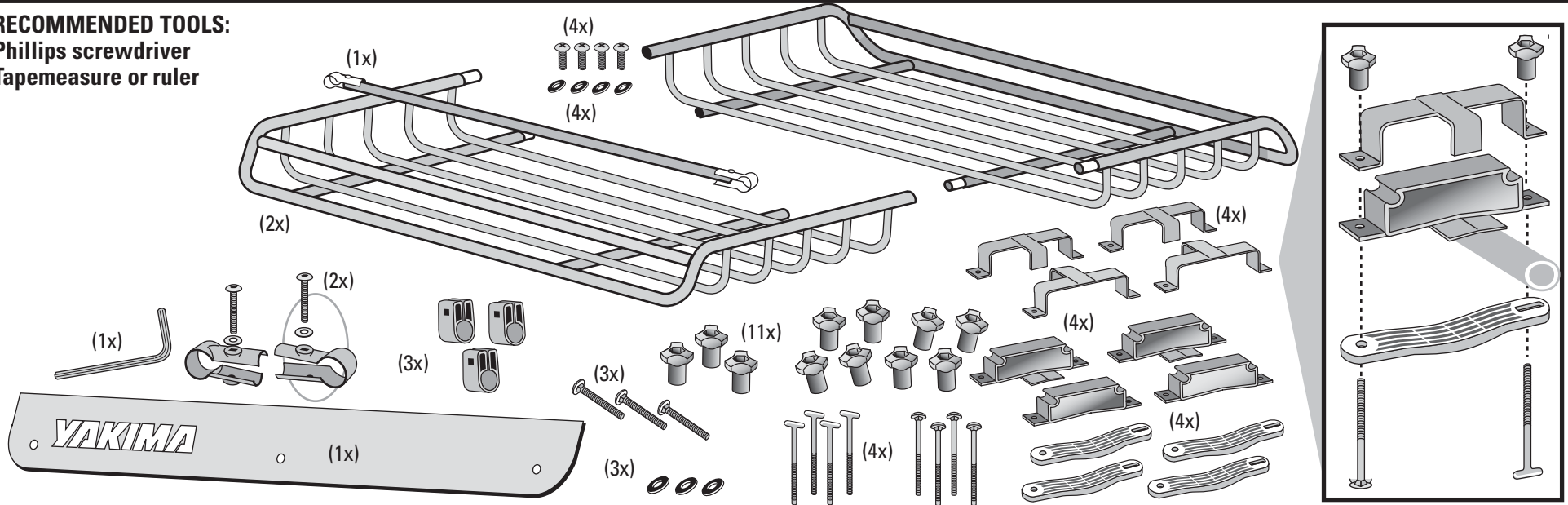

# MEGA WARRIOR

**RECOMMENDED TOOLS:**  
Phillips screwdriver  
Tapemeasure or ruler



**US**  **LOAD LIMITS:**

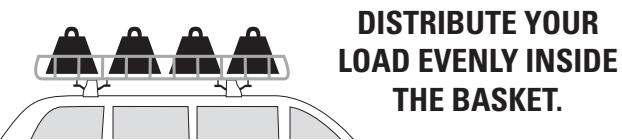
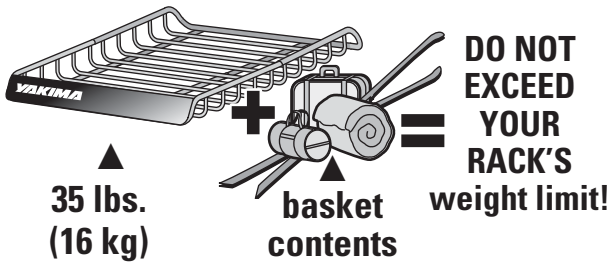

 **DO NOT EXCEED BASKET CONTENT WEIGHT LIMIT: 130 LBS. (60 KG)**

*Always tie down long loads at front and rear.*

•IF YOU HAVE FIXED BARS:

1

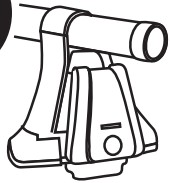

IF YOU HAVE "Q TOWERS"  
OR BARS THAT CANNOT MOVE...  
Continue to STEP 2.



**Q TOWER OWNERS:  
NEVER REPOSITION THE Q TOWERS!**

•IF YOUR BARS MOVE:

IF YOU HAVE BARS THAT CAN BE MOVED...  
Move the bars to minimum 30" (76cm) apart.



**TIGHTEN YOUR CROSSBARS  
IF YOU LOOSENED THEM.**

2 ASSEMBLE THE BASKET.

• Remove the machine screws from the ends of the LoadWarrior tubes.

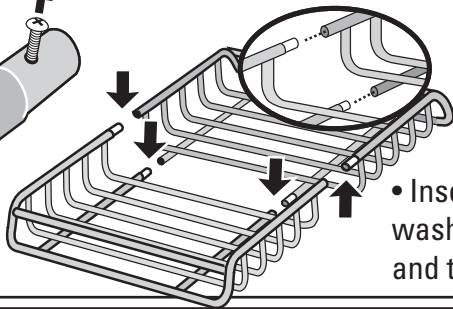
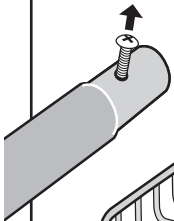

• Insert screws with washers into each joint and tighten them.



3 ATTACH FAIRING TO EITHER END OF BASKET.

Pry open the SnapArounds, attach them to the LOWER FRONT BAR.

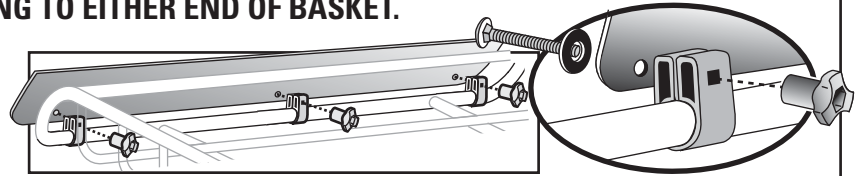
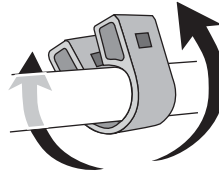

- Insert bolts through washers, fairing and SnapArounds.
- Attach knobs and TIGHTEN.

NOTE: The fairing can fold down when carrying accessories and long loads.

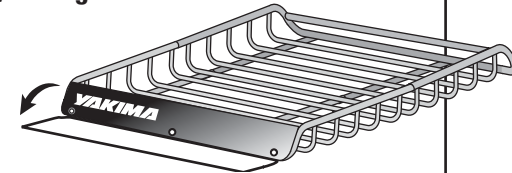

4 LOAD BASKET ONTO RACKS.  
Center basket over your rack's crossbars.

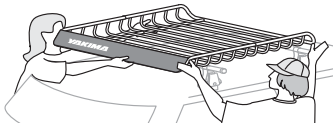

*A friend would make this easier.*



DO NOT ATTACH BRACKETS TO UNSTABLE POINTS.



Do not attach brackets at these locations.

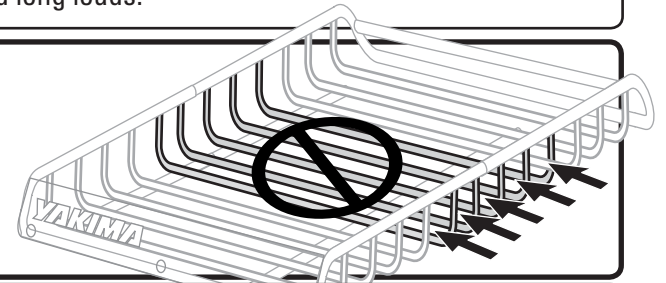

5 Position the support brackets above your vehicle's crossbars.

- Place the brackets OUTSIDE of the basket frame.
- Tabs on brackets face INBOARD.

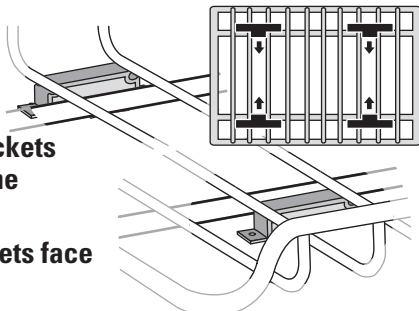

KEEP BAR BELOW TAB!

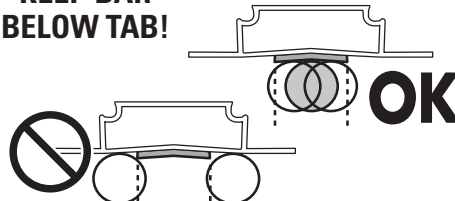

It may be necessary to move the bracket to a new position, or to adjust the basket position.

6 POSITION THE COVER BRACKETS.  
Position cover bracket onto installed support brackets.

Hooked tab should cover the larger support bar.

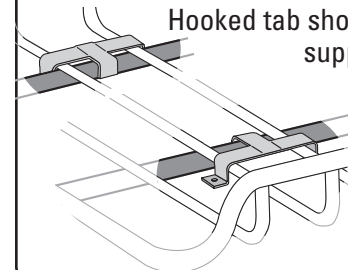

*Arrow points inboard to center of vehicle.*

**7 ATTACH BOLTS.**  
Insert bolt into round hole, and T-bolt into slotted hole.

**8 ATTACH THE KNOBS:**  
Engage the threads of the bolts.

**9 SECURE THE BASKET TO THE BARS.**  
Lock the T-Bolts.

**T-BOLT IS LOCKED** when the "T" of the bolt is turned inside the hole:

90°

**10 TIGHTEN THE KNOBS.**

**11 ATTACH LOAD BAR.**  
With a washer on the bolt, align the end clamps to the hole in the bar. Thread the bolts into the embedded nuts.

**DO NOT COVER JOINT SCREWS WITH END CLAMPS.**

**12 REFER TO THE DRAWINGS BELOW FOR BAR PLACEMENT, or to determine if the bar is required.**

**13** Tighten bolts while pushing the end clamps together.

**14 ACCESSORIES MUST BE ATTACHED TO THE FRONT OF THE BASKET (FRONT OF VEHICLE).**

<p><b>BIKES</b></p> <ul style="list-style-type: none"> <li>• Attach carrier at front of basket and to load bar.</li> <li>• Adjust the bar for load stability.</li> </ul>	<p><b>BOATS</b></p> <ul style="list-style-type: none"> <li>• For shorter boats, attach accessory at front of basket and to load bar.</li> <li>• Longer loads, such as canoes or sea kayaks, require the load bar to be removed.</li> </ul> <p><i>Long loads may interfere with LoadBar.</i></p>	<p><b>SKIS</b></p> <ul style="list-style-type: none"> <li>• Attach accessory at front of basket and to load bar.</li> </ul>
--	---	---

**15 CHECK INSTALLATION:**  
Make sure installation is secure by tugging at basket.

The basket should NOT SLIDE on the bars.

Tighten knobs.

**TO REMOVE THE BASKET, DO NOT DISASSEMBLE THE HARDWARE.**

- Loosen the knobs until barely attached.
- Unlock the T-bolts and let curved brackets swing freely.
- Remove basket.

**USE CAUTION WHEN OPENING YOUR HATCH.**

On some vehicles, hatch interference is unavoidable.

**Always tie down long loads to front and rear of vehicle.**