

YAKIMA *S.U.P. Brah Tie-Downs*

S.U.P. (1X)

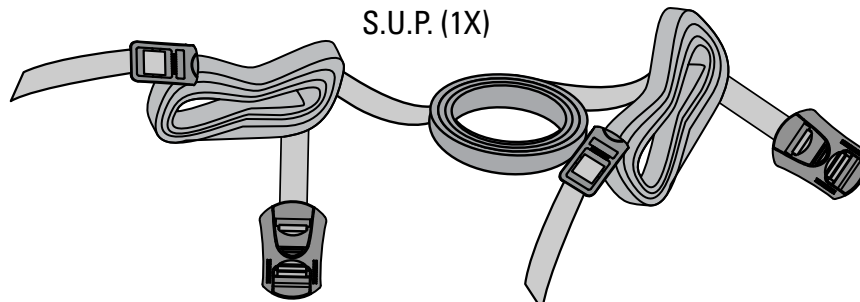

HOOK (2X)

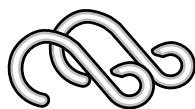

NOSE/TAIL STRAP (2X)

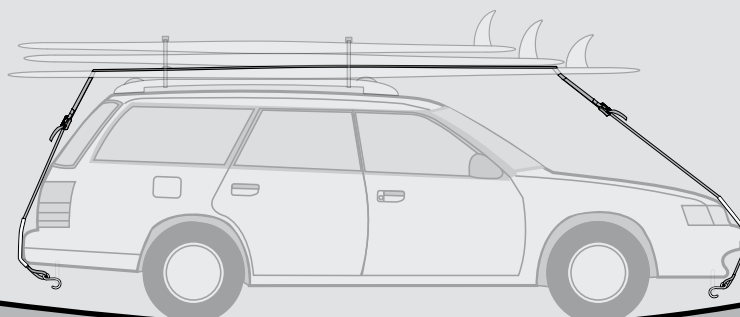
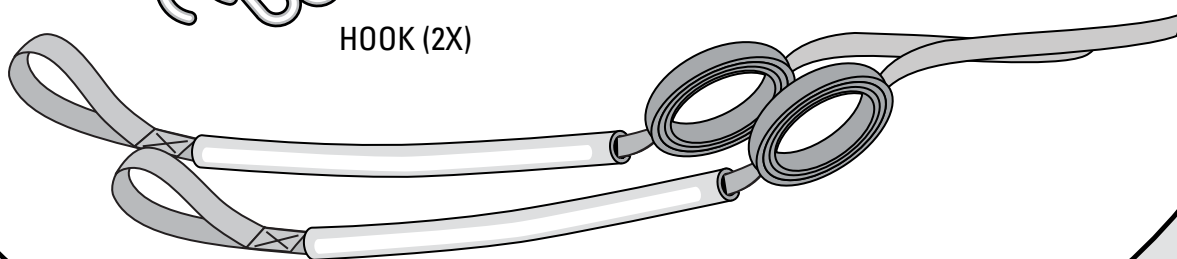

IMPORTANT WARNING

IT IS CRITICAL THAT ALL YAKIMA RACKS AND ACCESSORIES BE PROPERLY AND SECURELY ATTACHED TO YOUR VEHICLE. IMPROPER ATTACHMENT COULD RESULT IN AN AUTOMOBILE ACCIDENT, AND COULD CAUSE SERIOUS BODILY INJURY OR DEATH TO YOU OR TO OTHERS. YOU ARE RESPONSIBLE FOR SECURING THE RACKS AND ACCESSORIES TO YOUR CAR, CHECKING THE ATTACHMENTS PRIOR TO USE, AND PERIODICALLY INSPECTING THE PRODUCTS FOR ADJUSTMENT, WEAR, AND DAMAGE. THEREFORE, YOU MUST READ AND UNDERSTAND ALL OF THE INSTRUCTIONS AND CAUTIONS SUPPLIED WITH YOUR YAKIMA PRODUCT PRIOR TO INSTALLATION OR USE. IF YOU DO NOT UNDERSTAND ALL OF THE INSTRUCTIONS AND CAUTIONS, OR IF YOU HAVE NO MECHANICAL EXPERIENCE AND ARE NOT THOROUGHLY FAMILIAR WITH THE INSTALLATION PROCEDURES, YOU SHOULD HAVE THE PRODUCT INSTALLED BY A PROFESSIONAL INSTALLER.

1 Install S.U.P. Brah assembly to longest board.

Place Short red Tie-Down Loop around nose of board.

NOTE: Be sure flat side of buckle faces downward.

Place Long red Tie-Down Loop around tail of board.



If your board has fins be sure the loops clear the fins to avoid damaging them.



If your vehicle has an adjustable crossbar system, you must use the maximum possible crossbar spread when carrying long loads. Do not move your Q-Towers!

2 Tighten S.U.P. Brah assembly.

Pull strap taught to secure Tie-Down Loops to board. Secure strap end if necessary.

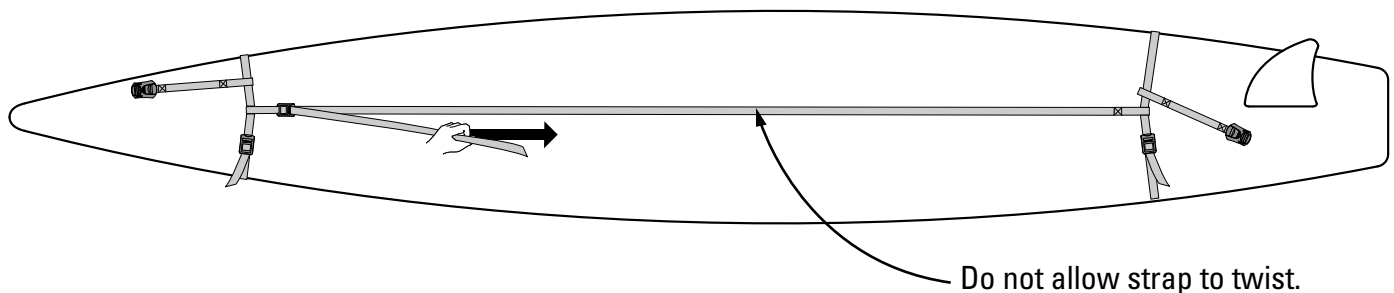

3 Center your board(s) on rack.

- Maximum capacity is three boards.
- Boards must be stacked. DO NOT INSTALL BOARDS SIDE BY SIDE.
- If multiple boards are carried use padding between boards to protect them.
- Boards can be loaded while in protective surfboard bags.
- Longest board must be on bottom and shortest board must be on top.
- Stack boards fins up and toward front of vehicle.

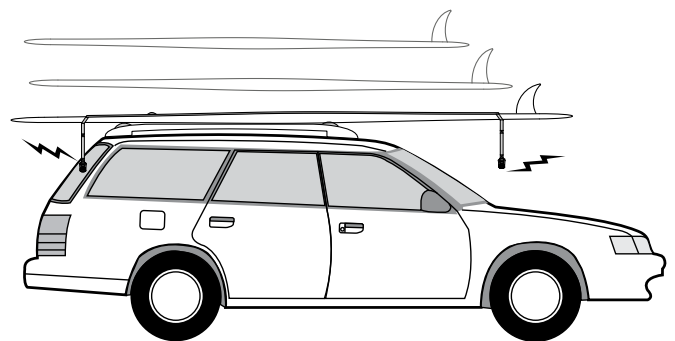

DO NOT ALLOW BUCKLES TO SLAM INTO YOUR VEHICLE!



MAXIMUM WEIGHT CANNOT EXCEED THE LOAD RATING OF THE ROOF RACK.

4 Move buckles to underside of board.

The buckles must be oriented underneath the board. If the buckles are not already underneath the board slide them around and underneath now.

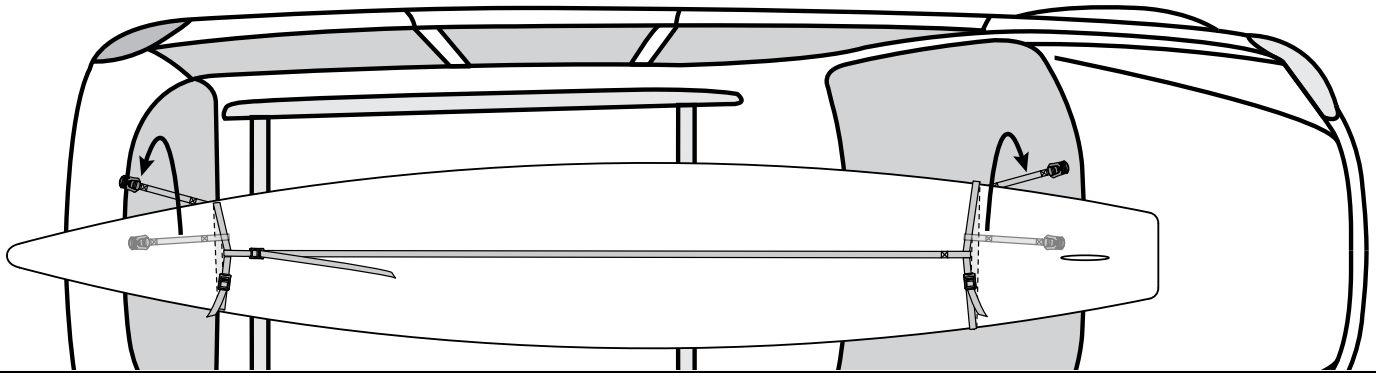

5 Attach nose/tail Straps.

Attach straps by threading the strap ends through the buckles. Be sure button is on top of buckle. Thread straps up through bottom of buckles.

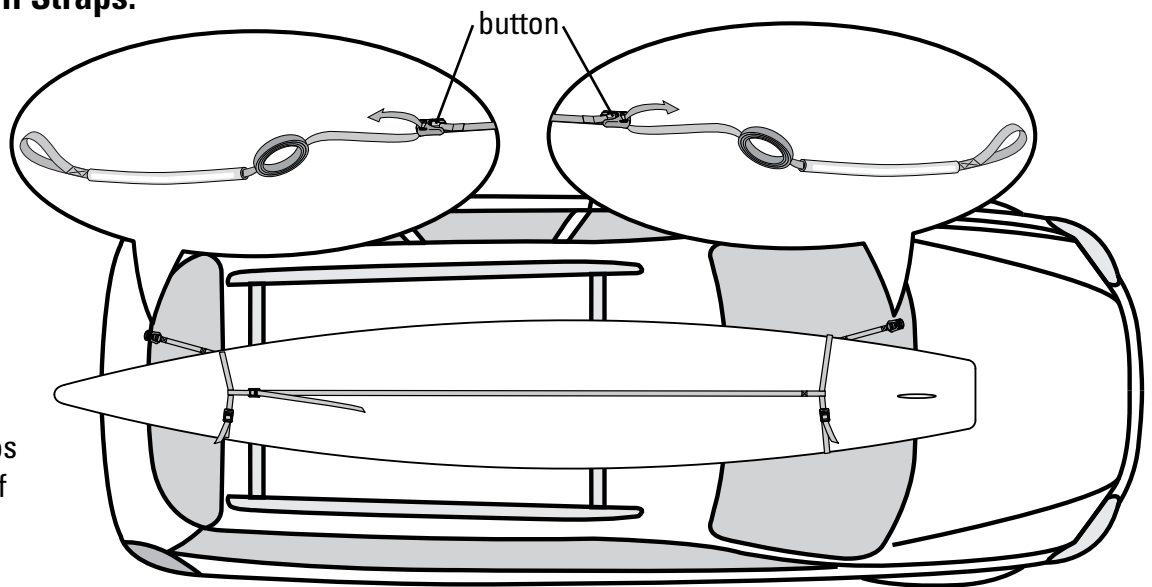

6 Attach metal hooks to nose/tail Strap.

Attach hooks to loops at end of nose/tail straps.

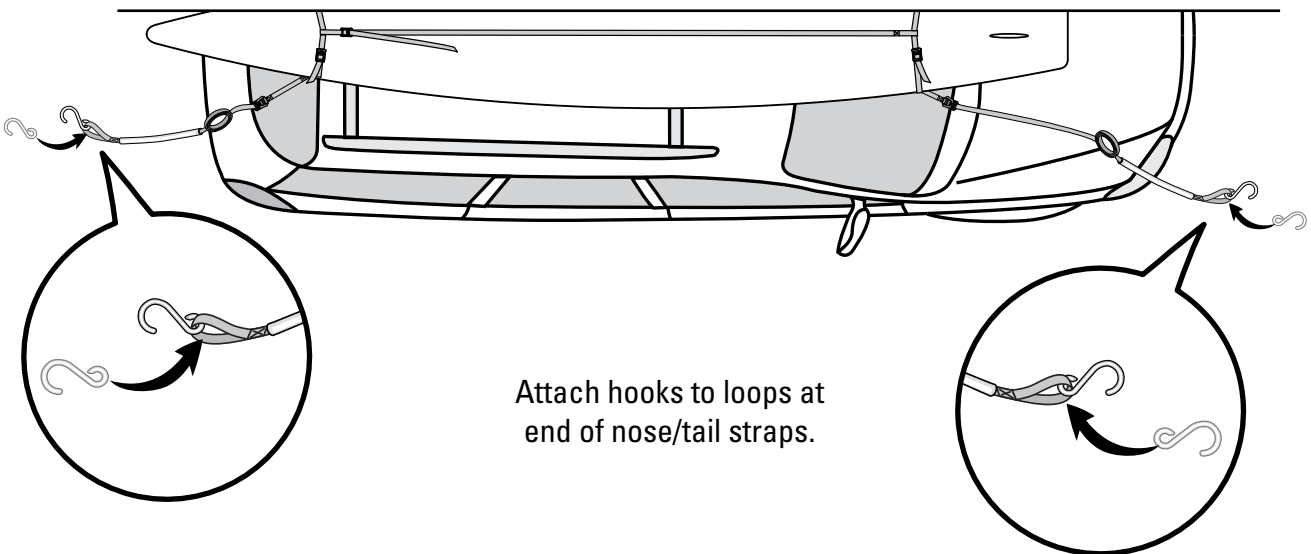

7 Attach metal hooks to Vehicle.

Attach hooks to tow loop or other metal surface of vehicle's frame.



DO NOT PULL STRAPS TIGHT YET. FINAL TIGHTENING IN STEP 8.

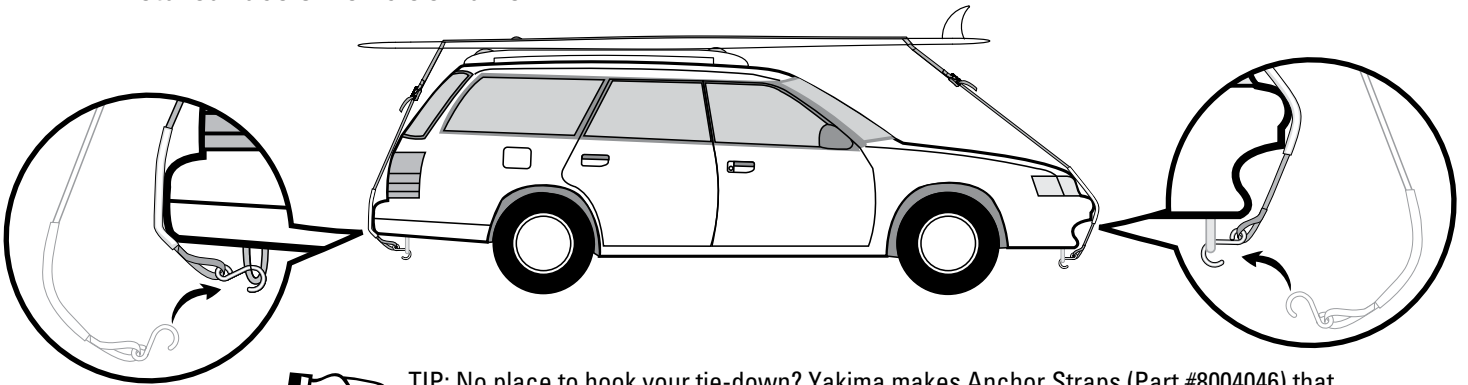

TIP: No place to hook your tie-down? Yakima makes Anchor Straps (Part #8004046) that allow you a tie-down point.



YOU MUST TIE-DOWN (NOT INCLUDED) YOUR LOAD TO THE RACK BEFORE PROCEEDING TO THE NEXT STEP.

RECOMMENDED TIE-DOWN PRODUCTS

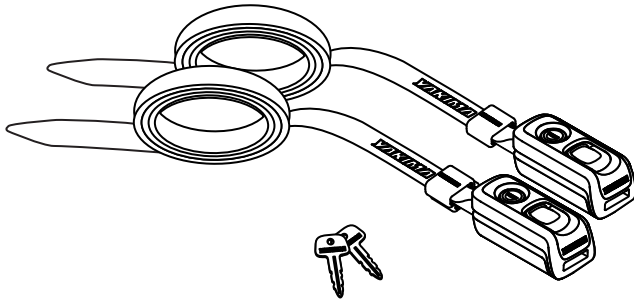

RipCord (part #8004048)

Secures and locks your boards to your rack.

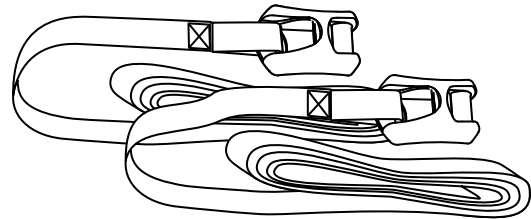

Heavy Duty Strap (part #8005006)

Secures your boards to your rack.

8 Adjust protector tubes, tighten nose/tail Straps.

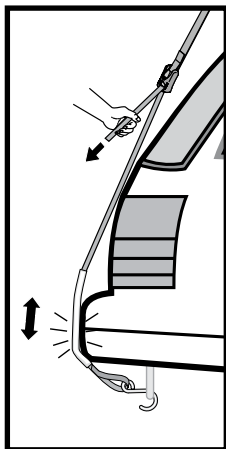

To avoid damage to your vehicle's finish slide plastic tube to cover areas where strap comes in contact with vehicle.

Pull strap ends to tighten. Secure extra strap if necessary.

