

**Install Universal
MightyMounts opening to
the front of the vehicle.**

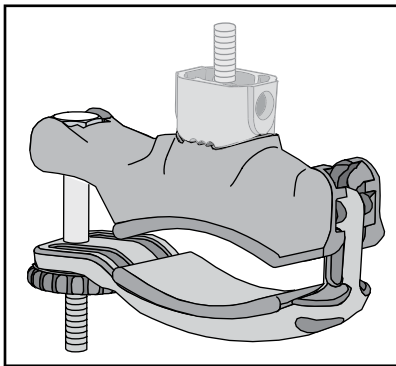
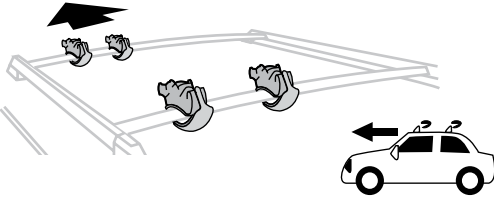

(shown for accessory, Cobra bike carrier)

- Follow the Fitting Process on the next page to match the size of your factory or square bars.
- Do not install KayakStackers (single-post style), HullRaisers, or AnkleBiters. They will not work with this product.

4 EACH:

Kit contains 4 of each piece of hardware (excluding the wrench).

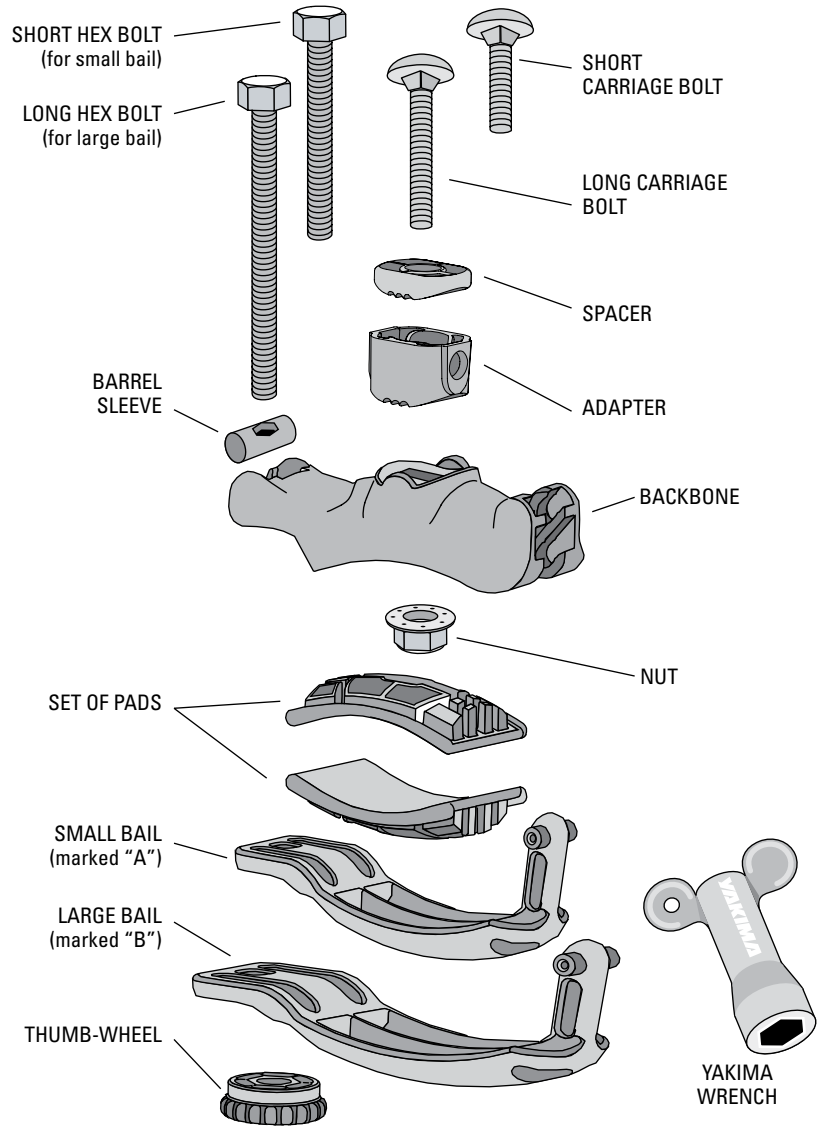

IMPORTANT WARNING!

IT IS CRITICAL THAT ALL YAKIMA RACKS AND ACCESSORIES BE PROPERLY AND SECURELY ATTACHED TO YOUR VEHICLE. IMPROPER ATTACHMENT COULD RESULT IN AN AUTOMOBILE ACCIDENT, AND COULD CAUSE SERIOUS BODILY INJURY OR DEATH TO YOU OR TO OTHERS. YOU ARE RESPONSIBLE FOR SECURING THE RACKS AND ACCESSORIES TO YOUR CAR, CHECKING THE ATTACHMENTS PRIOR TO USE, AND PERIODICALLY INSPECTING THE PRODUCTS FOR ADJUSTMENT, WEAR, AND DAMAGE. THEREFORE, YOU MUST READ AND UNDERSTAND ALL OF THE INSTRUCTIONS AND CAUTIONS SUPPLIED WITH YOUR YAKIMA PRODUCT PRIOR TO INSTALLATION OR USE. IF YOU DO NOT UNDERSTAND ALL OF THE INSTRUCTIONS AND CAUTIONS, OR IF YOU HAVE NO MECHANICAL EXPERIENCE AND ARE NOT THOROUGHLY FAMILIAR WITH THE INSTALLATION PROCEDURES, YOU SHOULD HAVE THE PRODUCT INSTALLED BY A PROFESSIONAL INSTALLER SUCH AS A QUALIFIED GARAGE OR AUTO BODY SHOP.

FITTING PROCESS (Find the parts that fit your crossbars.)

1 INSTALL PADS TO ONE SET OF MOUNTS.

Press a pad into the smaller bail (marked "A").

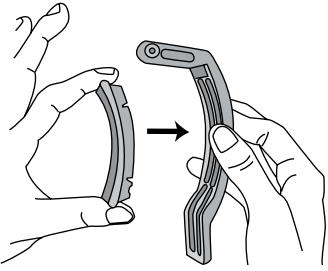

Press a pad into the backbone. (You may need to rotate the pad to fit correctly.)

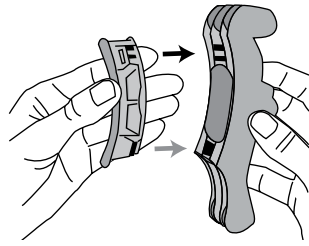

2 ATTACH SMALL BAIL TO BACKBONE.

Use the upper hinge slot on the backbone.

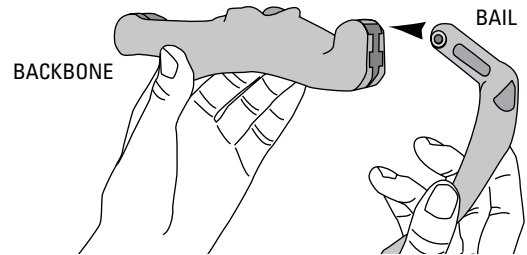

3 Place the mount onto the bar, opening toward the front of the car.

- Close and compress the mount around the bar.
- Insert a short hex bolt into the hex opening in the barrel sleeve, and insert into mount.

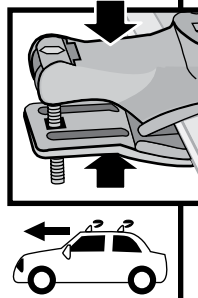
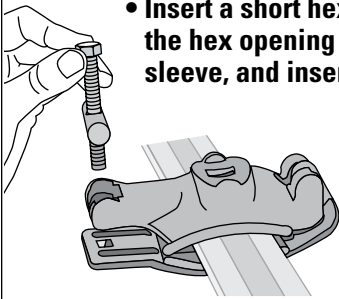

Bolt threads MUST extend below the closed bail.

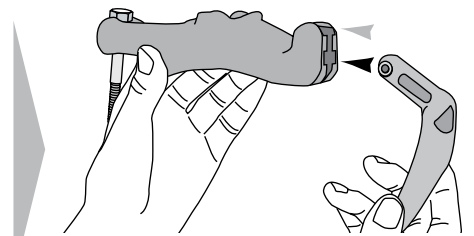

IF THE BOLT DOES NOT EXTEND, remove the bail, and set the end into the lower slot.

Always use the **SHORT** bolt with **SMALL** bail — and **LONG** bolt with **LARGE** bail.

4 IF THE BOLT THREADS STILL DO NOT EXTEND BELOW THE CLOSED BAIL:

- Use the larger bail (marked "B") with longer bolt.
- Repeat step 2 and 3.

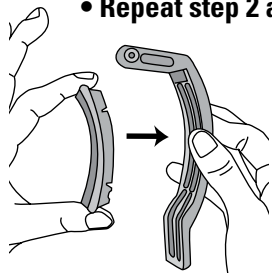

Always install the pad on the bail for this fitting process.

5 ATTACH THE THUMB-WHEEL:

If there is any looseness, or the mounts can slide on the bar, follow the fitting process again.



Repeat the fitting process until the MightyMount conforms to the size of your crossbars when the wheel is tightened.

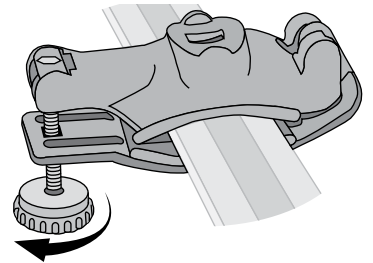

6 REMOVE THE FITTED MOUNT FROM THE BAR.

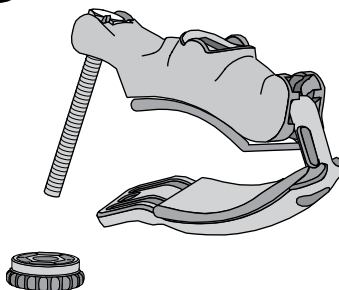

- Assemble the remaining mounts, and carefully set them aside.
- Do not discard the unused parts (you may use them on future vehicles).

7

USE THE ACCESSORY CHART ON THE FOLLOWING PAGES.

- Determine which carriage bolt you will need, and whether adapter or spacer will be used.
- Some parts may replace your accessory hardware. Follow the diagrams in the chart.

ACCESSORY CHART

1. Find your accessory, and follow the diagram.
2. Install the spacer or the adapter depending on your accessory.

SNOW*

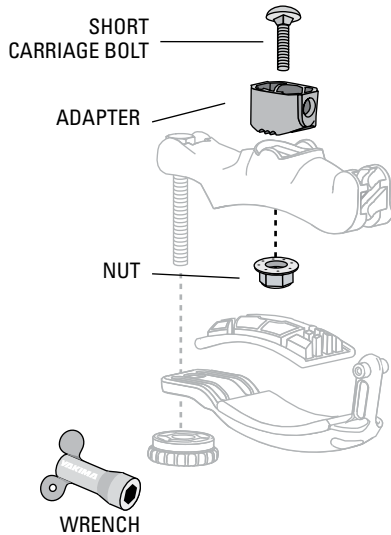

REMOVE THE UPPER PAD BEFORE CONTINUING.

1. Insert the short carriage bolt into the adapter and attach to the accessory using the accessory's hardware.
2. Secure the adapter and accessory to the backbone using the wrench.
3. Reattach the pad.
4. Attach to crossbar, secure with bail and wheel.
5. Read warnings on final page!

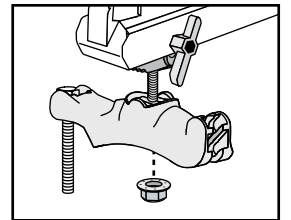
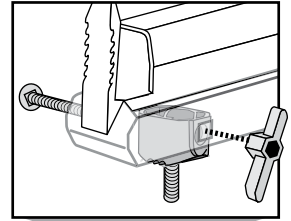

ADAPTER POSITION:

If your factory bars are angled, and the adapter is not flat against the accessory, loosen the carriage bolt and rotate the adapter on the MightyMount.

You will need to remove the pad; be sure to replace it once the bolt is tightened.

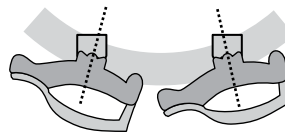

SNOW*

with added binding clearance



*** DO NOT INSTALL WITH SNOW ACCESSORIES ONTO ROUND BARS.**
This product cannot support ski/snowboard accessories when installed onto symmetrically rounded crossbars.

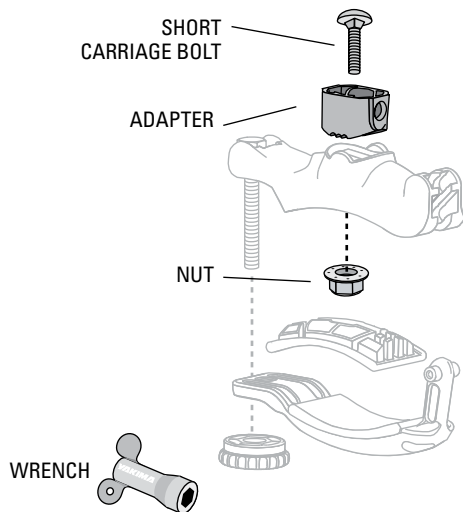

REMOVE THE UPPER PAD BEFORE CONTINUING.

1. Insert the short carriage bolt into the adapter and attach to the accessory using the accessory's hardware.
2. Secure the adapter and accessory to the backbone using the wrench.
3. Reattach the pad.
4. Attach to crossbar, secure with bail and wheel.
5. Read warnings on final page!

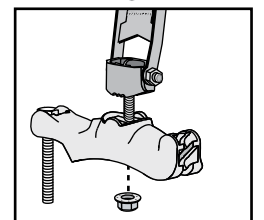
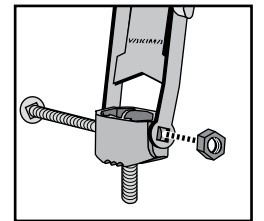

ADAPTER POSITION:

If your factory bars are angled, and the adapter is not flat against the accessory, loosen the carriage bolt and rotate the adapter on the MightyMount.

You will need to remove the pad; be sure to replace it once the bolt is tightened.

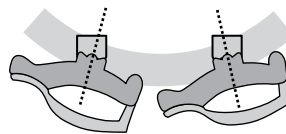

ACCESSORY CHART

1. Find your accessory, and follow the diagram.
2. Install the spacer or the adapter depending on your accessory.

WHEELFORK for use with Forklift

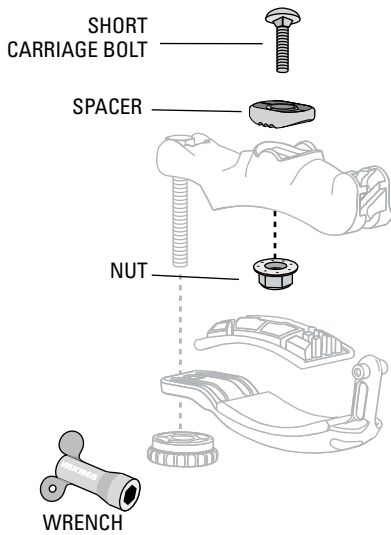

ANTI-SPIN PAD

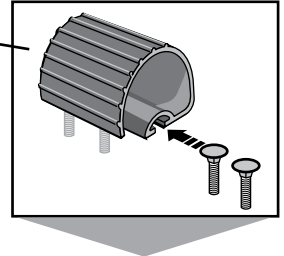

REMOVE THE UPPER PAD BEFORE CONTINUING.

1. Insert the short carriage bolts into the anti-spin pad and through the Wheelfork, spacer, and into the MightyMounts.
2. Secure the spacer and accessory to the backbone using the wrench.
3. Reattach the pad.
4. Attach to crossbar, secure with bail and wheel.
5. Read warnings on final page!

WHEELFORK

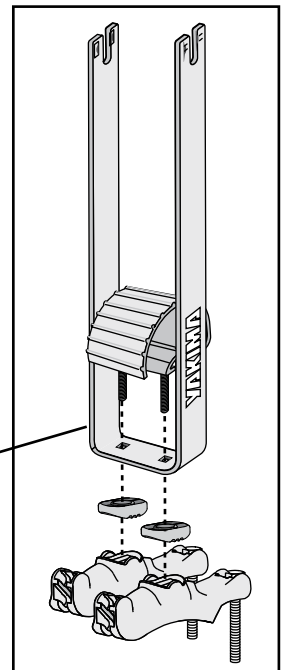

ADAPTER POSITION:

If your factory bars are angled, and the spacer is not flat against the accessory, loosen the carriage bolt and rotate the spacer on the MightyMount.

You will need to remove the pad; be sure to replace it once the bolt is tightened.

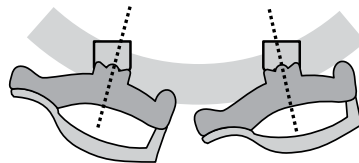

WATER* and UPRIGHT BIKES**



***KAYAK STACKERS (single-post style) will not work with this product.**

****HULLRAISERS will not work with this product.**

****ANKLEBITERS will not work with this product.**

****COBRA CARRIERS SEE BELOW.**

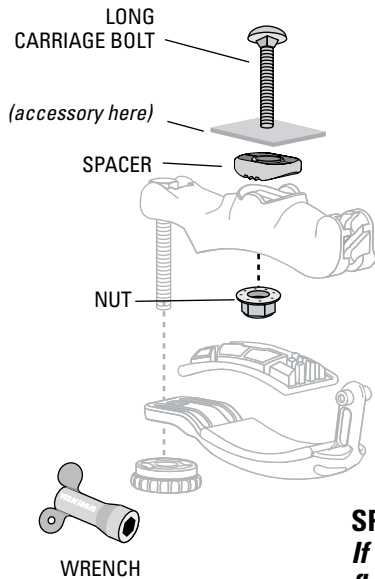

REMOVE THE UPPER PAD BEFORE CONTINUING.

1. Insert the long carriage bolt through the accessory and into the spacer (your accessory may look different).
2. Secure the spacer and accessory to the backbone using the nut. Tighten with wrench.
3. Reattach the pad.
4. Attach to crossbar, secure with bail and wheel.
5. Read warnings on final page!

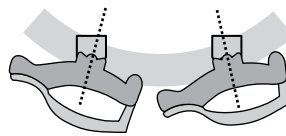
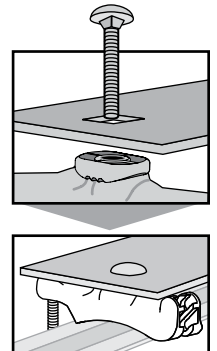

SPACER POSITION:

If your factory bars are angled, and the spacer is not flat against the accessory, loosen the carriage bolt and rotate the spacer on the MightyMount.

You will need to remove the pad; be sure to replace it once the bolt is tightened.



BIKE WHEEL TRAY:
Use the short carriage bolt from this kit.

Cobra and KingCobra

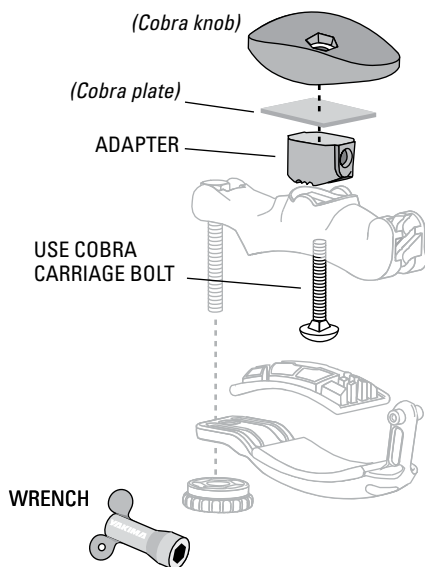

REMOVE THE UPPER PAD BEFORE CONTINUING.

1. Insert the carriage bolt from your Cobra carrier, through the adapter and the Cobra plate.
2. Secure the adapter and Cobra plate to the backbone using the Cobra knob.
3. Reattach the pad.
4. Attach to crossbar, secure with bail and wheel.
5. Read warnings on final page!

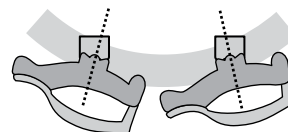
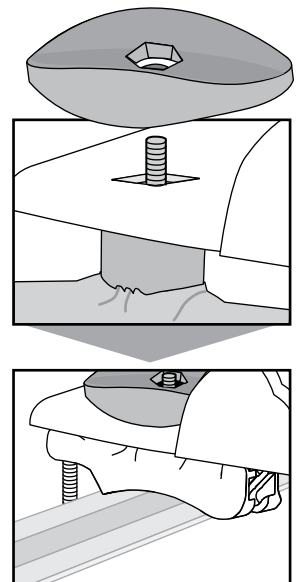

ADAPTER POSITION:

If your factory bars are angled, and the adapter is not flat against the accessory, loosen the carriage bolt and rotate the adapter on the MightyMount.

You will need to remove the pad; be sure to replace it once the bolt is tightened.

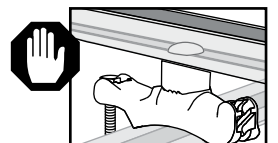

COBRA WHEEL TRAY:
Use the long carriage bolt from this kit.

HighRoller

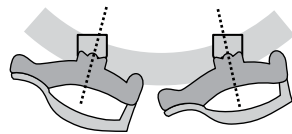
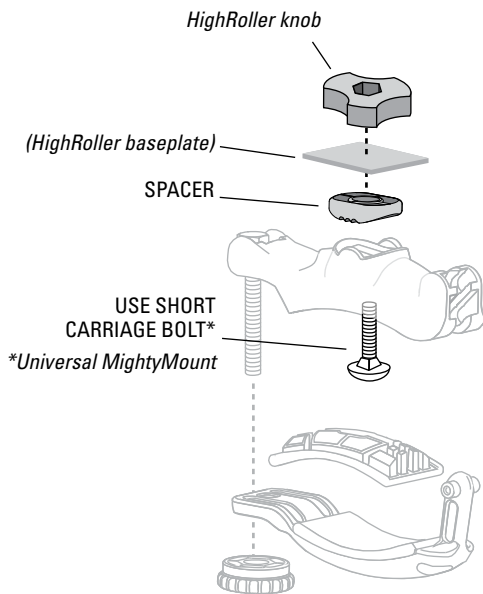

REMOVE THE UPPER PAD BEFORE CONTINUING.

1. Insert the short carriage bolt (from Universal MightyMount), through the spacer and the HighRoller baseplate.
2. Secure the spacer and baseplate to the backbone using the HighRoller knob.
3. Reattach the pad.
4. Attach to crossbar, secure with bail and wheel.
5. Read warnings on final page!

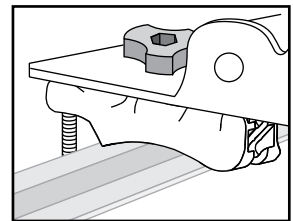
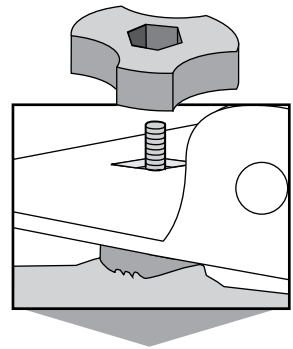

SPACER POSITION:

If your factory bars are angled, and the spacer is not flat against the accessory, loosen the carriage bolt and rotate the spacer on the MightyMount.

You will need to remove the pad; be sure to replace it once the bolt is tightened.

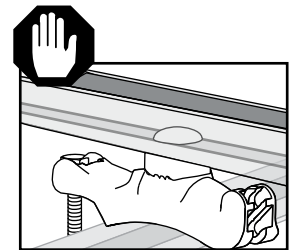

HIGHROLLER WHEEL TRAY:
Use the short carriage bolt and spacer from this kit.

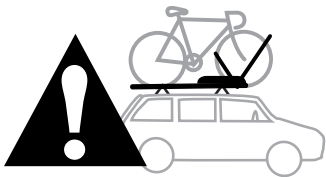

BIKE WEIGHT LIMIT:
MAXIMUM BIKE WEIGHT IS 30 LBS. (14 KG).

BASKET CASE (cargo):

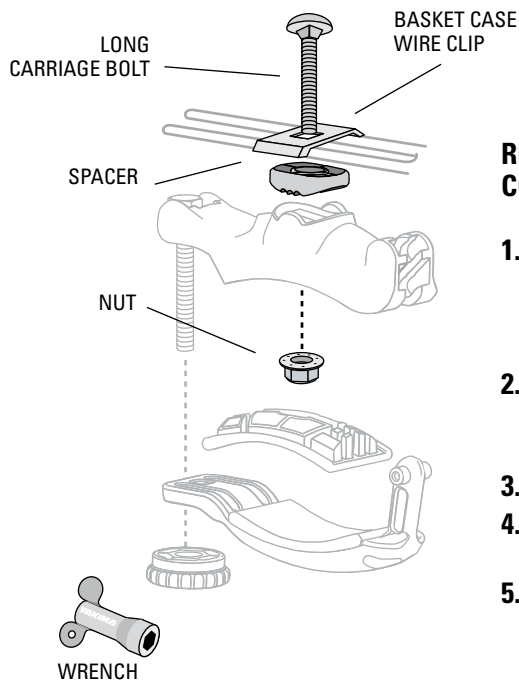

REMOVE THE UPPER PAD BEFORE CONTINUING.

1. Insert the long carriage bolt through the wire-clip and basket loops, into the spacer and backbone.
2. Secure the spacer and basket to the backbone using the nut. Tighten with wrench.
3. Reattach the pad.
4. Attach to crossbar, secure with bail and wheel.
5. Read warnings on final page!

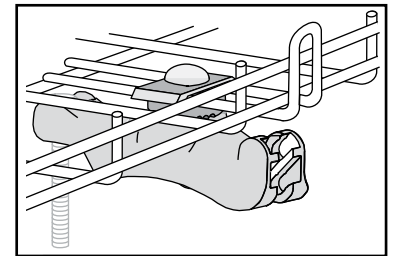

Be sure the bolts pass through the wire loops on the *BOTTOM* of the basket.

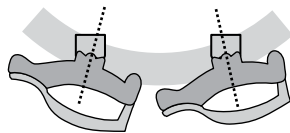

SPACER POSITIONING:

If your factory bars are angled, and the spacer is not flat against the accessory, loosen the carriage bolt and rotate the spacer on the MightyMount.

You will need to remove the pad, be sure to replace it once the bolt is tightened.

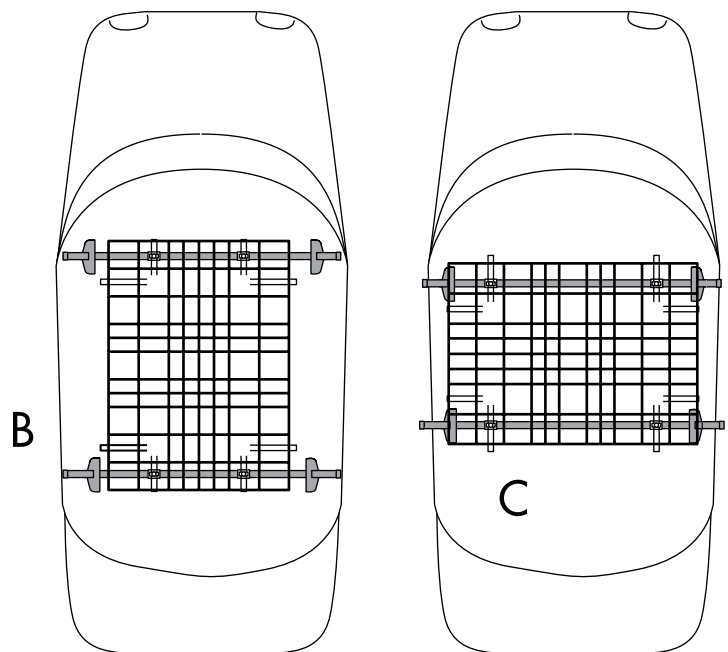

Basket will sit above bars as in option B and C (BasketCase instructions).

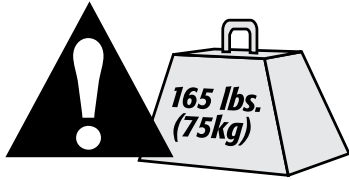

WEIGHT LIMITS

Follow the YAKIMA Fit List for your rack's weight limit.

DO NOT EXCEED THE WEIGHT LIMIT OF YOUR VEHICLE'S RACKS.

Maximum weight is 165 lbs. (75 kg) unless otherwise noted.

REMOVING YOUR ACCESSORY

Unscrew the wheels, carefully remove your accessory from the car.

RE-INSTALLING ACCESSORY

- Carefully tighten the thumb-wheels after reinstallation.
- **FOLLOW SAFETY CHECKS IN ACCESSORY INSTRUCTIONS EVERY INSTALLATION.**



ACCESSORY LOCKS CAN LOCK THE MOUNTS TO THE RACKS

(lock housings purchased separately)

- There must be adequate clearance for installing accessory locks.
- If the accessory lock housing comes in contact with the vehicle, even after loading the rack, do not install them.

TIE DOWN LONG LOADS.

Always tie down both ends of long loads to vehicle. Failure to do so can result in property damage, personal injury, or death.

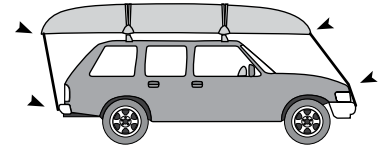

REAR HATCH

Some longer loads may prevent the rear hatch from fully opening.

ALWAYS USE CAUTION WHEN OPENING YOUR HATCH.

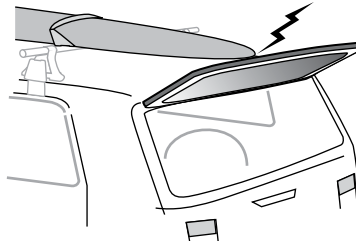

ANTENNA

Antenna on the roof may need to be removed to prevent interference with long loads.

WARNING: BE SURE ALL HARDWARE IS SECURED ACCORDING TO INSTRUCTIONS. ATTACHMENT HARDWARE CAN LOOSEN OVER TIME. CHECK BEFORE EACH USE, AND TIGHTEN IF NECESSARY.

MAINTENANCE

Use non-water soluble lubricant on screws. Use a soft cloth with water and mild detergent to clean plastic parts.

REMOVE ACCESSORY BEFORE ENTERING AN AUTOMATIC CAR WASH.



KEEP THESE INSTRUCTIONS!