

YAKIMA *Glass Hatch Hooks* ADAPTERS



**READ THE JOE INSTRUCTIONS BEFORE
INSTALLING THESE ADAPTERS**

and



*Find your vehicle in the Joe Fit Sheet, read the notes to
determine if the TOP STRAP HOOKS or LOWER STRAP
HOOKS should be replaced.*

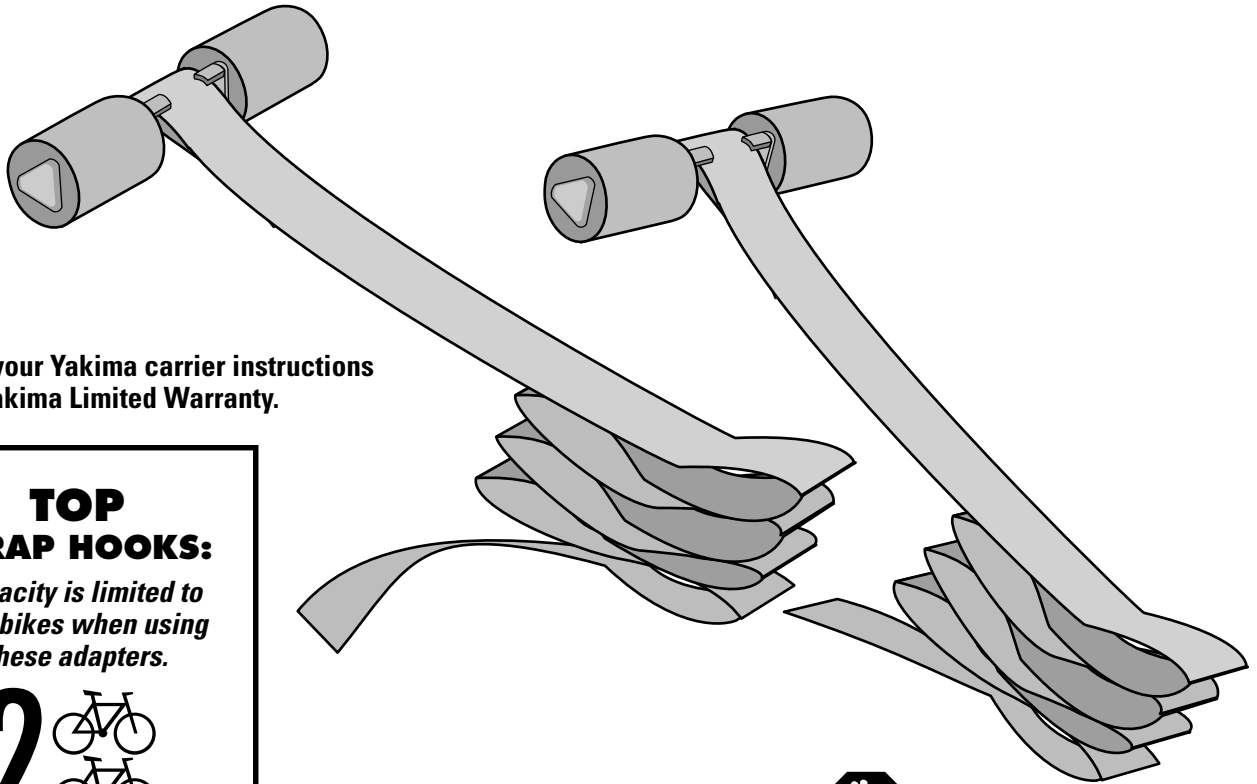

Refer to your Yakima carrier instructions
for the Yakima Limited Warranty.

TOP STRAP HOOKS:

*Capacity is limited to
two bikes when using
these adapters.*



NOTICE!

**If you have been advised to use these adapters,
failure to do so will result in damage to your vehicle.**



IMPORTANT WARNING

IT IS CRITICAL THAT ALL YAKIMA RACKS AND ACCESSORIES BE PROPERLY AND SECURELY ATTACHED TO YOUR VEHICLE. IMPROPER ATTACHMENT COULD RESULT IN AN AUTOMOBILE ACCIDENT, AND COULD CAUSE SERIOUS BODILY INJURY OR DEATH TO YOU OR TO OTHERS. YOU ARE RESPONSIBLE FOR SECURING THE RACKS AND ACCESSORIES TO YOUR CAR, CHECKING THE ATTACHMENTS PRIOR TO USE, AND PERIODICALLY INSPECTING THE PRODUCTS FOR ADJUSTMENT, WEAR, AND DAMAGE. THEREFORE, YOU MUST READ AND UNDERSTAND ALL OF THE INSTRUCTIONS AND CAUTIONS SUPPLIED WITH YOUR YAKIMA PRODUCT PRIOR TO INSTALLATION OR USE. IF YOU DO NOT UNDERSTAND ALL OF THE INSTRUCTIONS AND CAUTIONS, OR IF YOU HAVE NO MECHANICAL EXPERIENCE AND ARE NOT THOROUGHLY FAMILIAR WITH THE INSTALLATION PROCEDURES, YOU SHOULD HAVE THE PRODUCT INSTALLED BY A PROFESSIONAL INSTALLER SUCH AS A QUALIFIED GARAGE OR AUTO BODY SHOP.

1

Find your vehicle in the Joe Fit Sheet and read the notes to determine if the **TOP STRAP HOOKS** or **LOWER STRAP HOOKS** should be replaced.



Replacing TOP STRAP HOOKS:

2

REMOVE THE CARRIER FROM THE CAR.

Pull straps completely out of the buckles.

BUCKLE STYLES:

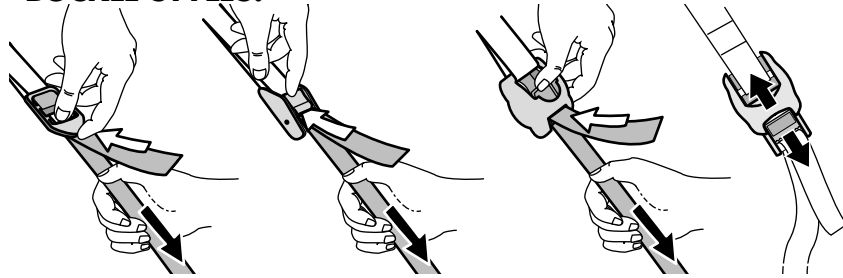

If you cannot access the buckle, you may need to slide back the rubber cover.

3

Open the hatch door.

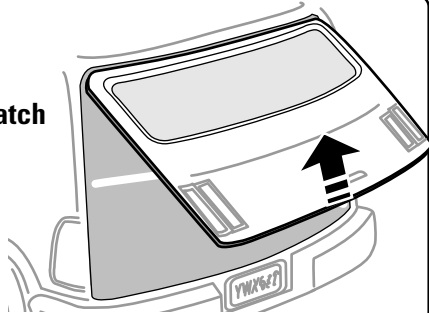

4

Pass the strap ends through the hatch opening from inside the vehicle.

Keep the pads away from the door's edge.

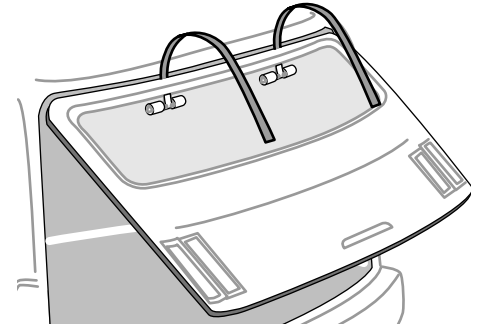

5

BEFORE CLOSING THE HATCH...

The pads must be free from contact between hatch door and vehicle's frame.

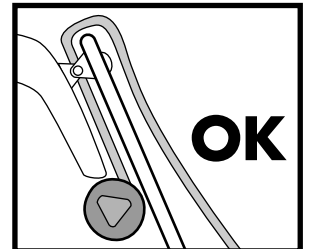
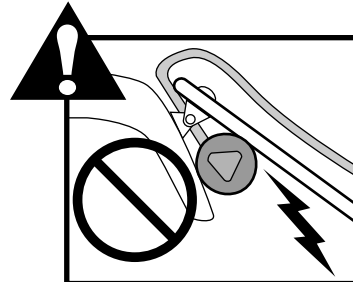
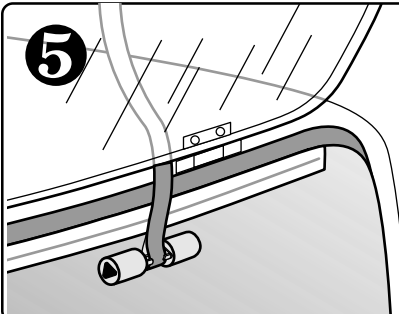

6

Close the hatch.

Pull firmly on the straps to seat the pads.

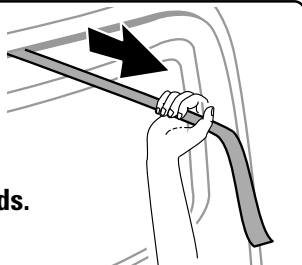

7

While supporting the carrier with your body, attach the adapter straps to your carrier's top straps.

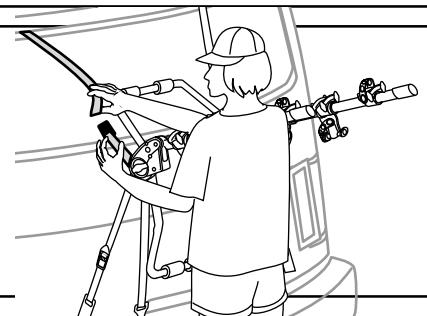

8

THREAD NEW STRAP-END BACK INTO BUCKLE.

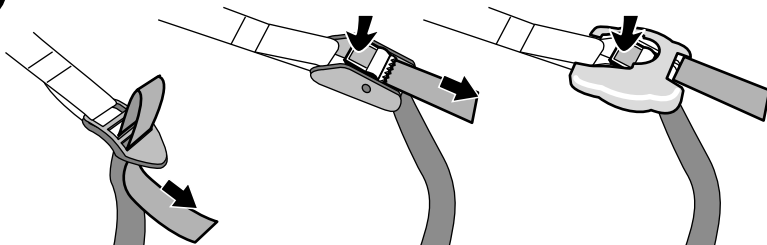

If you cannot access the buckle, you may need to slide back the rubber cover.

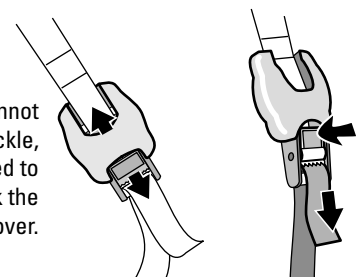

9

Continue with your Joe instructions to secure the carrier to your vehicle.



Find your vehicle in the Joe Fit Sheet and read the notes to determine if the **TOP STRAP HOOKS** or **LOWER STRAP HOOKS** should be replaced.

Replacing **LOWER STRAP HOOKS**:

10 REMOVE THE CARRIER FROM THE CAR.
Pull lower straps completely out of the hub.

BUCKLE STYLES:

If you cannot access the buckle, you may need to slide back the rubber cover.

11 OPEN THE TRUNK DOOR.

12 Position the pads inside the trunk with the straps hanging free. Keep the pads away from the door's edge.

13 BEFORE CLOSING THE TRUNK, be sure the pads are free from contact between trunk door and vehicle's frame.

- CLOSE THE TRUNK.
- Pull firmly on the straps to seat the pads.

14

- Insert the new straps from inside the hubs, behind the red triggers.
- Attach the ends to the side hook buckles.

15 Attach the Top Strap Hooks to hold the carrier as you continue.

16 THREAD NEW STRAP-END BACK INTO BUCKLE.

If you cannot access the buckle, you may need to slide back the rubber cover.

17 Continue with your Joe instructions to secure the carrier to your vehicle.