

YAKIMA Landing Pad #8

Refer to YAKIMA Control Tower instructions for important warning and load limitations, and YAKIMA's limited warranty.

RECOMMENDED TOOLS:
5mm Allen wrench

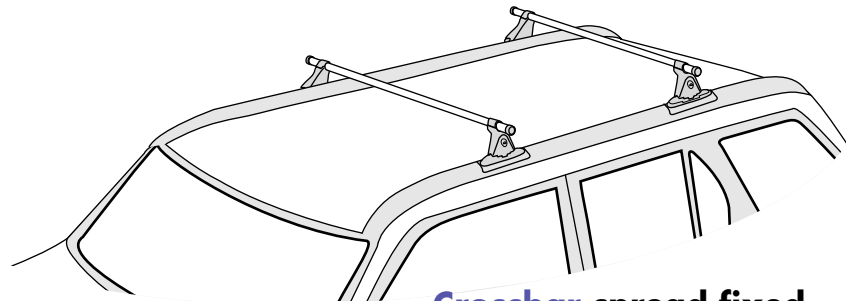

Crossbar spread fixed at 33 inches

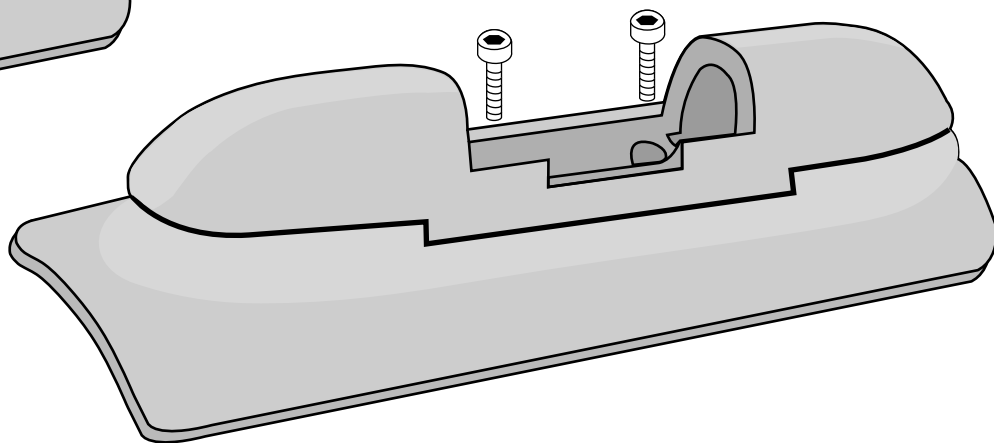
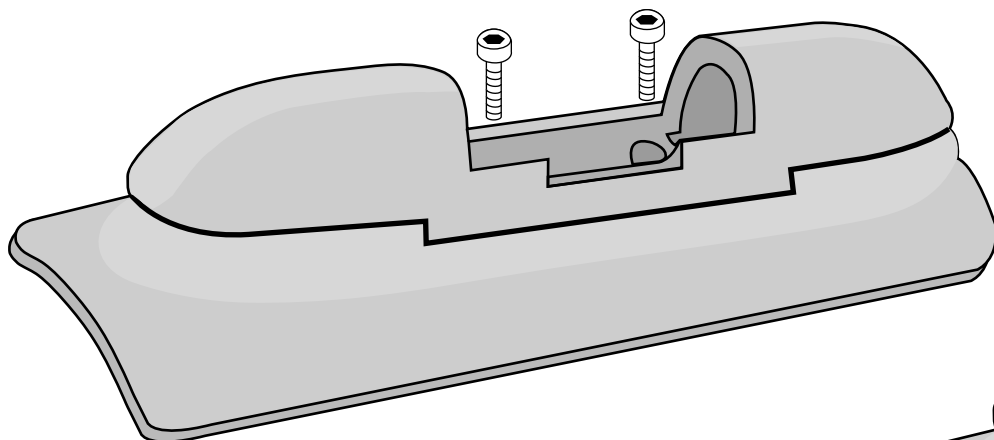

1

If your vehicle has factory crossbars, remove them now.

2

REMOVE TRIM COVER PLATES.

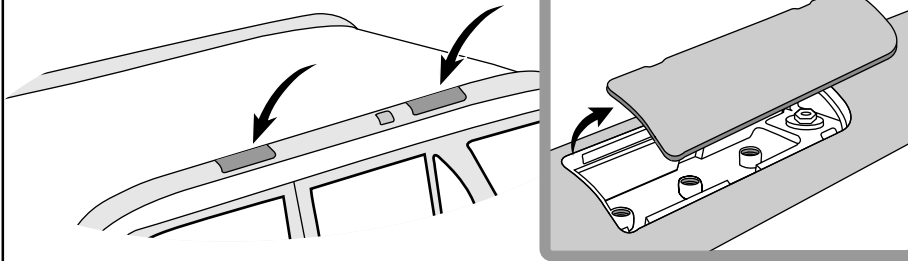

3

Prepare holes for installation by pre-installing screws. Install and remove until holes are free of debris.

Use the 2 holes closest to the rear of the vehicle.

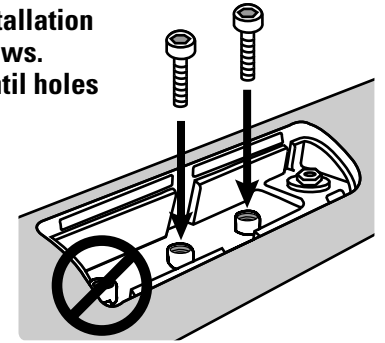

4

Remove cover from Landing Pad.

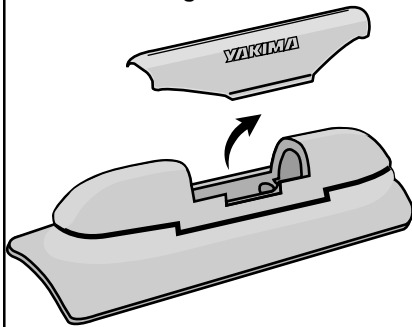

5

LUBRICATE THE BOLTS.
Apply a water-insoluble lubricant to bolts.

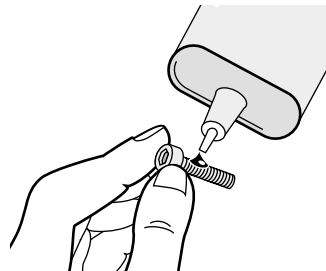

6

Align base with 2 rear holes.

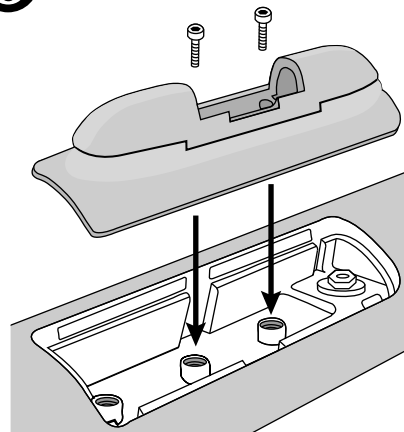

7

Hold Landing Pad firmly against rail while tightening. TIGHTEN COMPLETELY.

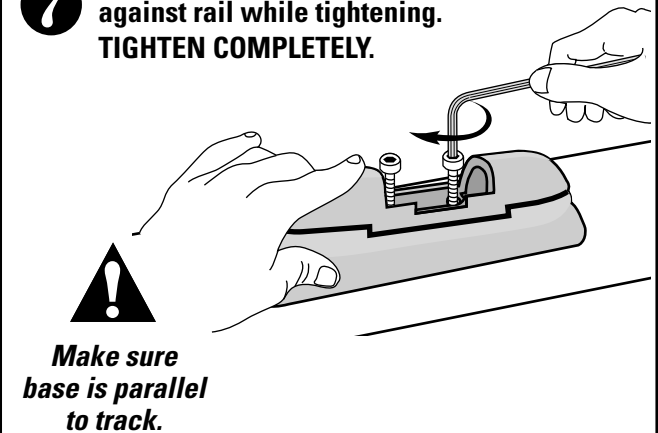

Make sure base is parallel to track.

READ THESE WARNINGS!



ATTACHMENT HARDWARE CAN LOOSEN OVER TIME. CHECK AND TIGHTEN IF NECESSARY, BEFORE EACH USE.

Be sure all hardware is secured according to instructions. Failure to perform safety checks before driving away can result in property damage, personal injury, or death.



- Consult your local dealer or fit list to see load limitations for accessories.
- Do not exceed your factory rack limitation.

Remove your YAKIMA rack and accessories before entering automatic car washes.

YOU ARE NOW READY TO PROCEED TO CONTROL TOWER INSTRUCTIONS.