

YAKIMA Landing Pad #6

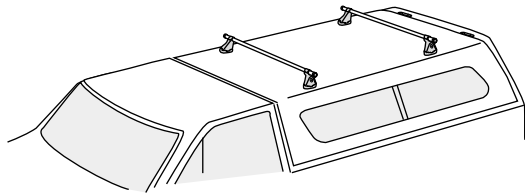

Weight & load limits are determined by the customer/installer and will vary depending upon the placement of the Landing Pads and the strength & construction of the material they are attached to.

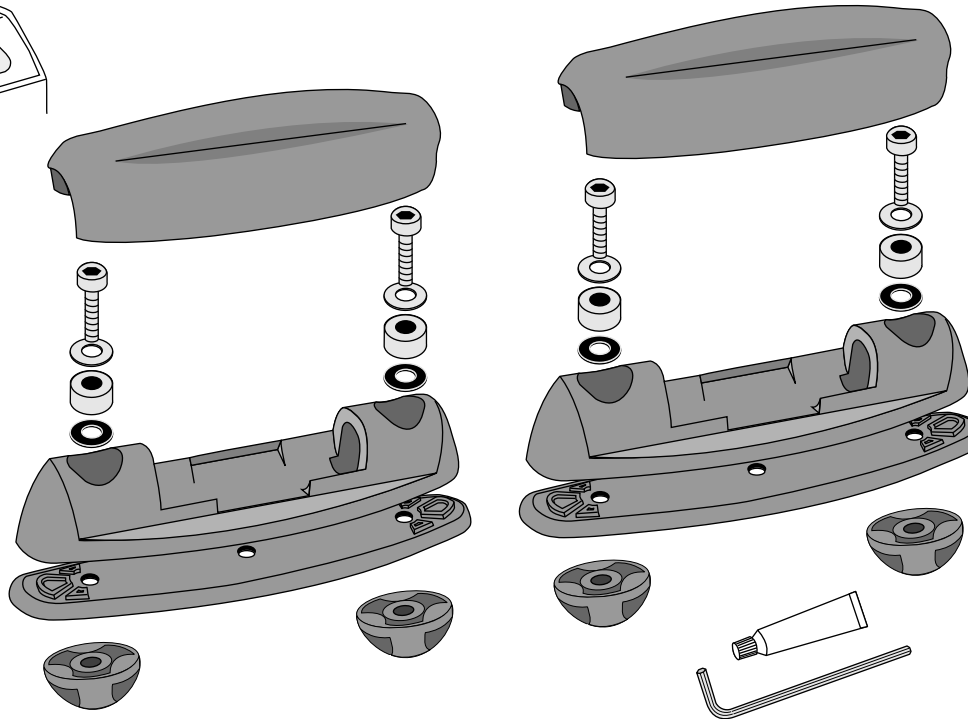

RECOMMENDED TOOLS:

Tape measure, #2 pencil, drill, 1/8" drill bit, 1/4" drill bit, punch and eye protection.

TO BEGIN, ASSEMBLE THE CONTROL TOWERS ONTO THE CROSSBARS:

1 Open Control Towers

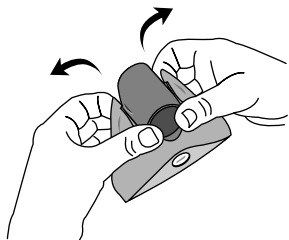

2 Using the wrench provided in the Control Tower carton, loosen towers.

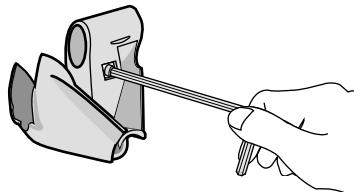

3 Slide two towers onto each crossbar. Do not tighten.

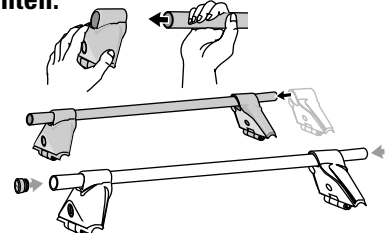

Be careful to keep the bars horizontal; the loose towers could slide from the bar and fall.

IMPORTANT WARNING!

IT IS CRITICAL THAT ALL YAKIMA RACKS AND ACCESSORIES BE PROPERLY AND SECURELY ATTACHED TO YOUR VEHICLE. IMPROPER ATTACHMENT COULD RESULT IN AN AUTOMOBILE ACCIDENT, AND COULD CAUSE SERIOUS BODILY INJURY OR DEATH TO YOU OR TO OTHERS. YOU ARE RESPONSIBLE FOR SECURING THE RACKS AND ACCESSORIES TO YOUR CAR, CHECKING THE ATTACHMENTS PRIOR TO USE, AND PERIODICALLY INSPECTING THE PRODUCTS FOR ADJUSTMENT, WEAR, AND DAMAGE. THEREFORE, YOU MUST READ AND UNDERSTAND ALL OF THE INSTRUCTIONS AND CAUTIONS SUPPLIED WITH YOUR YAKIMA PRODUCT PRIOR TO INSTALLATION OR USE. IF YOU DO NOT UNDERSTAND ALL OF THE INSTRUCTIONS AND CAUTIONS, OR IF YOU HAVE NO MECHANICAL EXPERIENCE AND ARE NOT THOROUGHLY FAMILIAR WITH THE INSTALLATION PROCEDURES, YOU SHOULD HAVE THE PRODUCT INSTALLED BY A PROFESSIONAL INSTALLER SUCH AS A QUALIFIED GARAGE OR AUTO BODY SHOP.

4 Remove cover from Landing Pad.

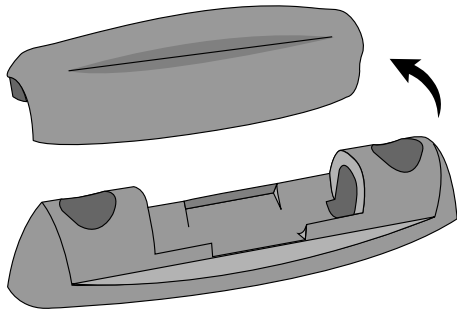

5 Attach Control Tower to Landing Pad

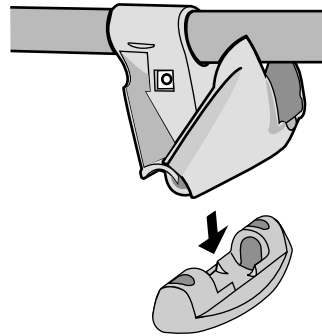

6 Close cover.

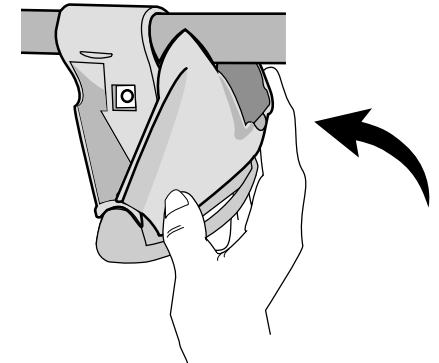

7 Use assembled to determine placement on vehicle.

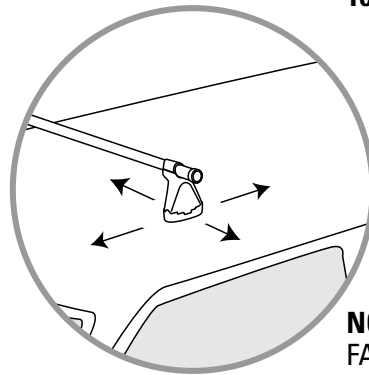
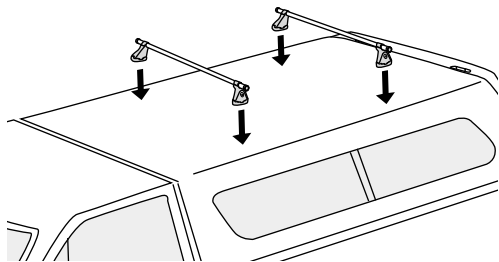

Arrange Towers on canopy from front to back and side to side. Place Towers considering the following:

- Design and strength of construction of vehicle.
- Compatibility of accessories and crossbar spread requirements. (See side bar).
- Easy access to loaded accessories.

NOTE: IF YOU HAVE NO MECHANICAL EXPERIENCE AND ARE NOT THOROUGHLY FAMILIAR WITH THE INSTALLATION PROCEDURES, YOU SHOULD HAVE THE PRODUCT INSTALLED BY A PROFESSIONAL INSTALLER SUCH AS A QUALIFIED GARAGE OR AUTO BODY SHOP.

CROSSBAR REQUIREMENTS:

The distance between the Yakima crossbars is determined by the accessories you wish to carry.

Refer to the instructions for the accessory to determine how much crossbar spread your accessories require.

8 With the Control Tower cover open, mark the outline of the holes on the vehicle roof with a #2 pencil.

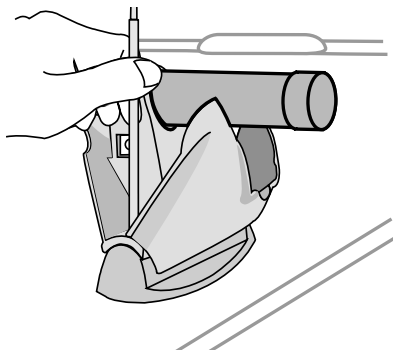

Use eye protection!



9 Center punch the holes.

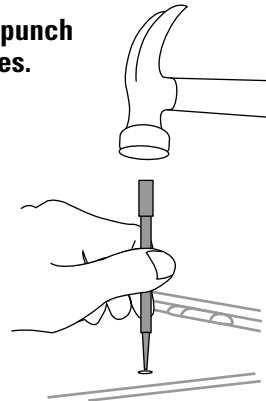

10 Drill 1/8" pilot holes.

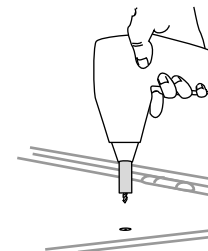

- Drill final hole size with 1/4" drill bits.

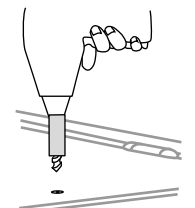

Do not drill through Landing Pads.

11 Carefully blow away debris.

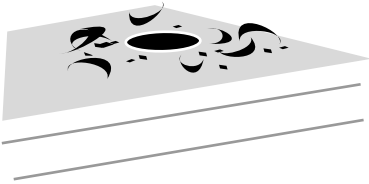

12 Apply a silicone bead around the holes.



WARNING: Direct contact of uncured sealant irritates eyes and may irritate skin. Overexposure to vapor may irritate eyes, nose and throat. Avoid eye and skin contact. Use with adequate ventilation. Do not handle contact lenses with sealant on hands. In case of eye contact, flush with water for 15 minutes. Obtain medical attention. In case of skin contact, remove from skin and flush with water. Sealant releases acetic acid (vinegar-like odor) during cure.

13 Take off Towers and assemble Landing Pads.

- Attach rubber pads.

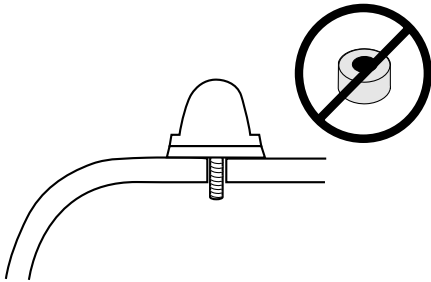
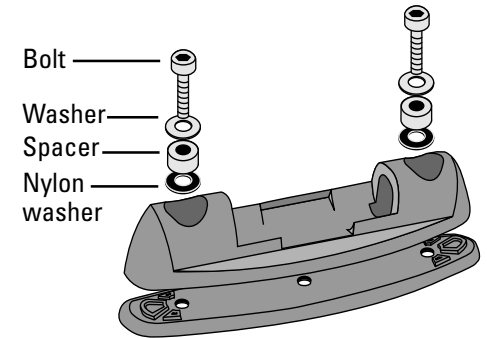

NOTE:

Due to manufacturing variances, shell thickness can differ considerably. You may need to eliminate spacer or obtain longer bolts from your local hardware store. Use a stainless steel, sockethead 10-32 bolt in the desired length).

14 Install assembled Landing Pads into holes.

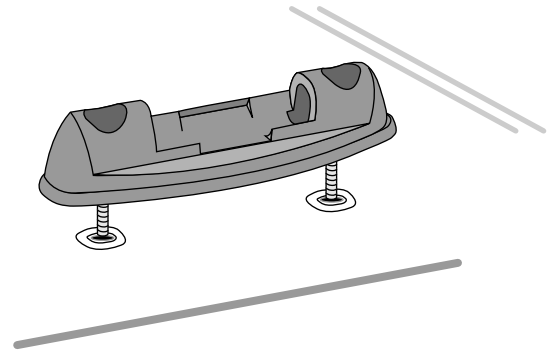

15 Engage cap with screw. Do not tighten fully.

A helpful friend will make this easier.

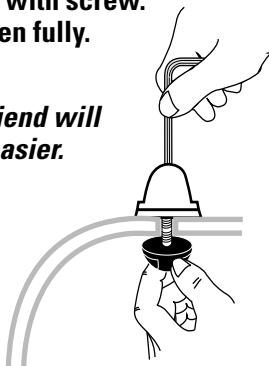

16 Attach Control Towers and finish tightening bolts.

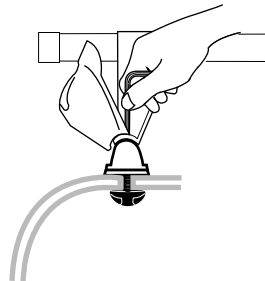

17 Push down and fully tighten Towers.

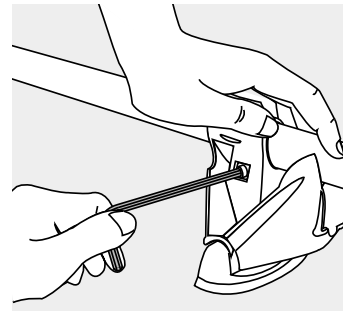

18 Firmly close covers until both sides snap.

"SNAP"

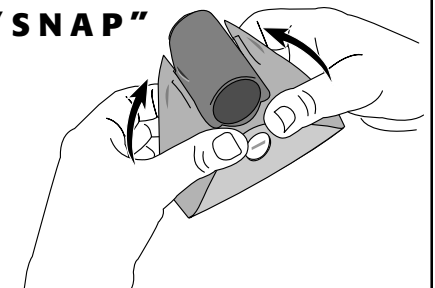

BEFORE DRIVING AWAY:



Test the Installation:
Push up on bar end to test installation. Grab the bar near the towers and pull back and forth.

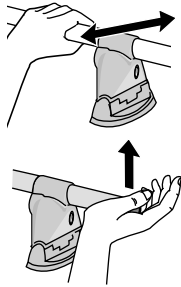

SKS® Lock Cores are optional.

Refer to Lock Core instructions for installation.

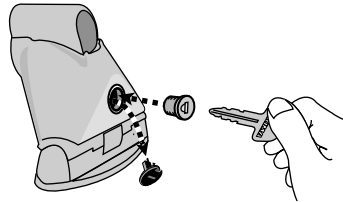

Use the Landing Pad cover when the Control Tower is not in use.

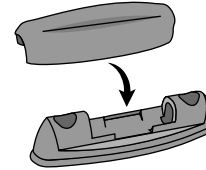

READ THESE WARNINGS!

Weight & load limits are determined by the customer/installer and will vary depending upon the placement of the Landing Pads and the strength & construction of the material they are attached to.



REMOVE YOUR YAKIMA RACK AND ACCESSORIES BEFORE ENTERING AUTOMATIC CAR WASHES.



ATTACHMENT HARDWARE CAN LOOSEN OVER TIME. CHECK AND TIGHTEN IF NECESSARY, BEFORE EACH USE.

BEFORE DRIVING AWAY:

SECURE FRONT AND REAR OF LONG LOADS (I.E. BOATS) TO ENDS OF VEHICLE FOR SAFE TRANSPORT. FAILURE TO PERFORM SAFETY CHECKS BEFORE DRIVING AWAY CAN RESULT IN PROPERTY DAMAGE, PERSONAL INJURY, OR DEATH.

OFF-ROAD DRIVING is not recommended and could result in damage to your vehicle or your gear.

KEEP THESE INSTRUCTIONS!