

YAKIMA Landing Pad #4

Refer to YAKIMA Control Tower instructions for important warning and load limitations, and YAKIMA's limited warranty.

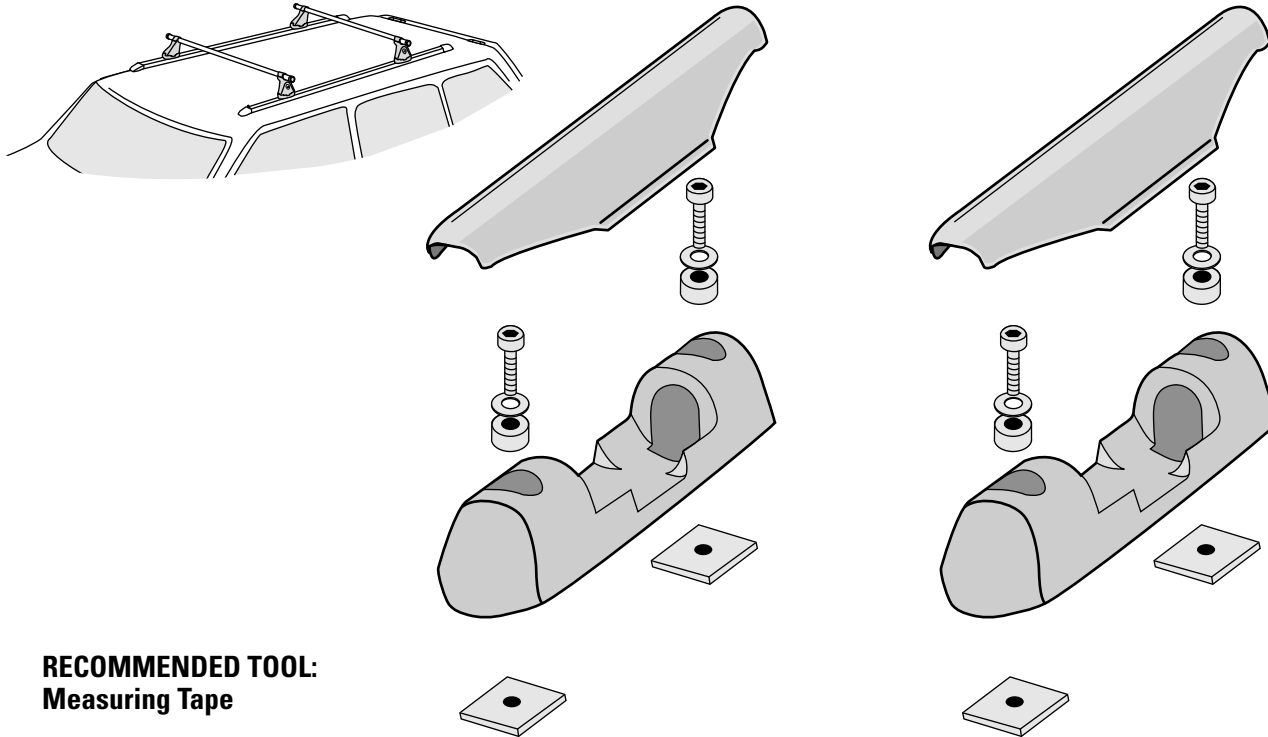

RECOMMENDED TOOL:
Measuring Tape



You may need to remove your vehicle's factory crossbars and slats. Check to see if Landing Pad location will cause interference. Refer to your vehicle's owner's manual for details on factory rack removal.

1 Remove covers from Landing Pads.

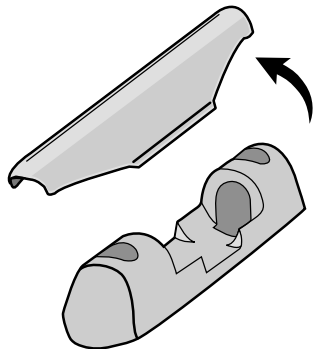

2 Use existing nut-plates when possible. Four per track are required.

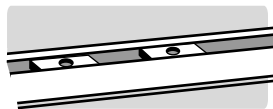

- Factory crossbars or accessories may need to be removed.
- IF THERE ARE FEWER than 4 plates per track, install additional plates.

3 Remove end cap from track.

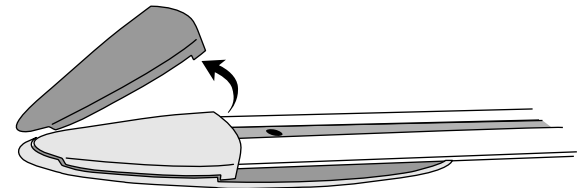

NOTE: Refer to vehicle owner's manual for details on factory rack removal.

4 Position the plates for best fit inside the tracks.

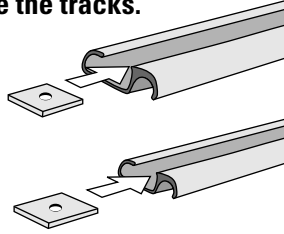

or

5 Replace end caps.

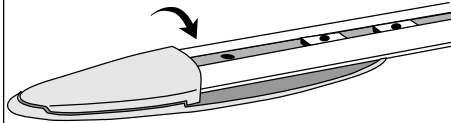

6 Install screw with spacer and washer into pad.

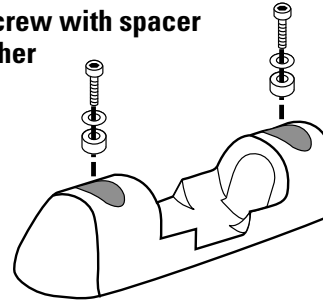

7 Align screws in Landing Pads with plates.

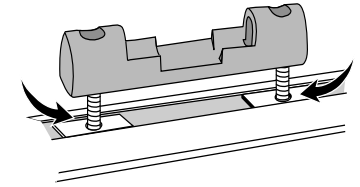

NOTE:

If screws seem too short and are not engaging the plate, take out screw, remove plastic spacer, use washer only.

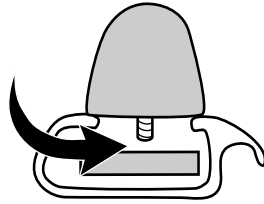

In some cases, it may be easier to assemble plates, screws, and bases before sliding onto tracks.

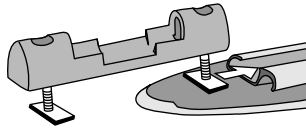

8 Engage the screw with wrench supplied. Do not fully tighten.

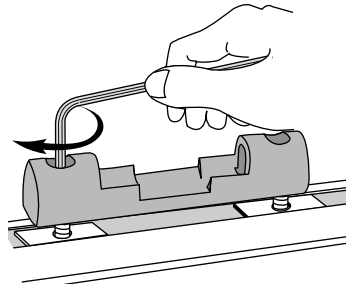

9 Arrange Landing Pads on the tracks in the approximate positions where the Control Towers will be attached.

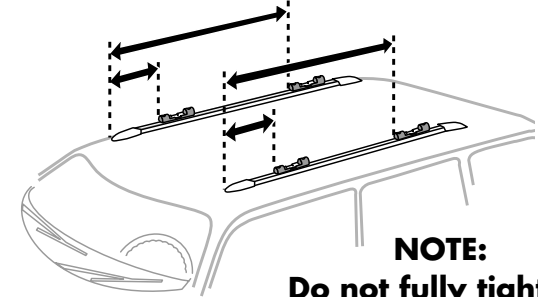

NOTE:
Do not fully tighten. Final adjustments will be made after Control Tower is installed.

10 Installation Tips:

CROSSBAR SPREAD:

The distance between the Yakima crossbars is determined by the accessories you wish to carry.

The Crossbar Spread Table (Fit List or Catalog) will tell you how much crossbar spread your accessories require.

LOAD LOCATION:

For ease of loading, consider where the most convenient placement of your load would be before completing the installation.



USE CAUTION WHEN OPENING YOUR HATCH.

On some vehicles, hatch interference with accessories is unavoidable.

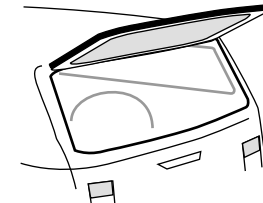

YOU ARE NOW READY TO PROCEED TO CONTROL TOWER INSTRUCTIONS