

YAKIMA

SkyBox

NO PRE-ASSEMBLY REQUIRED

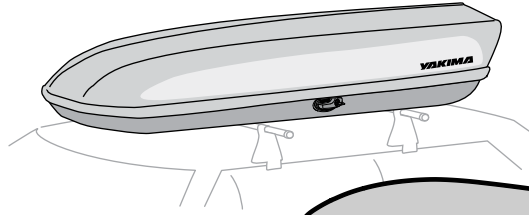

SKYBOX (1X)

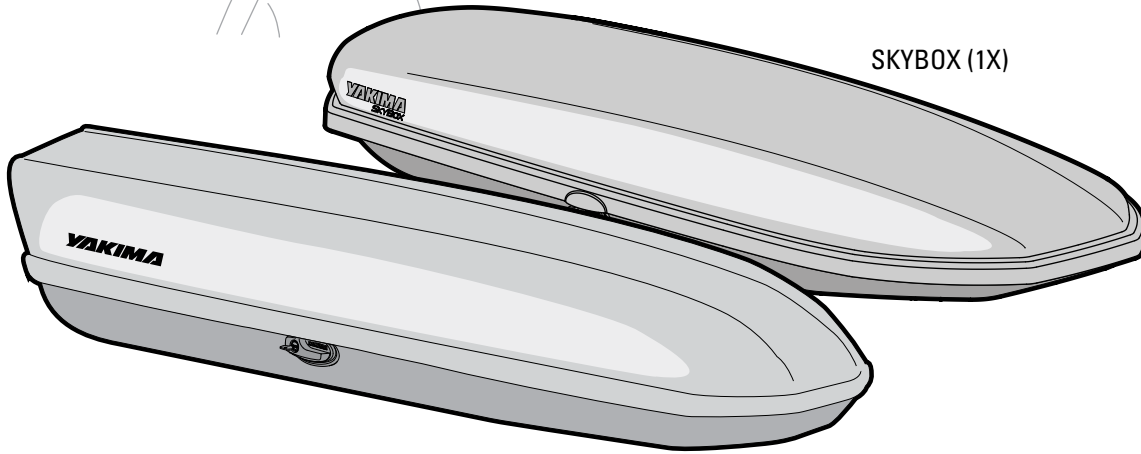

You may need a measuring tape or ruler.

MAXIMUM LOAD LIMITS:

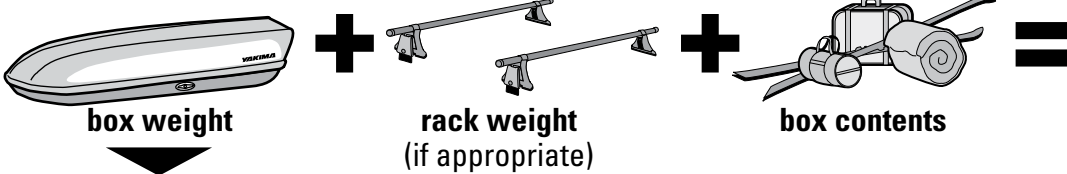

SkyBox 12.....	41 lbs. / 19 kg
SkyBox 16.....	47 lbs. / 21 kg
SkyBox 18.....	52 lbs. / 24 kg
SkyBox Lo.....	52 lbs. / 24 kg
SkyBox 21.....	62 lbs. / 28 kg

IMPORTANT WARNING!

IT IS CRITICAL THAT ALL YAKIMA RACKS AND ACCESSORIES BE PROPERLY AND SECURELY ATTACHED TO YOUR VEHICLE. IMPROPER ATTACHMENT COULD RESULT IN AN AUTOMOBILE ACCIDENT, AND COULD CAUSE SERIOUS BODILY INJURY OR DEATH TO YOU OR TO OTHERS. YOU ARE RESPONSIBLE FOR SECURING THE RACKS AND ACCESSORIES TO YOUR CAR, CHECKING THE ATTACHMENTS PRIOR TO USE, AND PERIODICALLY INSPECTING THE PRODUCTS FOR ADJUSTMENT, WEAR, AND DAMAGE. THEREFORE, YOU MUST READ AND UNDERSTAND ALL OF THE INSTRUCTIONS AND CAUTIONS SUPPLIED WITH YOUR YAKIMA PRODUCT PRIOR TO INSTALLATION OR USE. IF YOU DO NOT UNDERSTAND ALL OF THE INSTRUCTIONS AND CAUTIONS, OR IF YOU HAVE NO MECHANICAL EXPERIENCE AND ARE NOT THOROUGHLY FAMILIAR WITH THE INSTALLATION PROCEDURES, YOU SHOULD HAVE THE PRODUCT INSTALLED BY A PROFESSIONAL INSTALLER.

1

OPEN GEAR BOX.

- Insert key. Turn counter clock-wise to unlock.
- Rotate handle (handle will not rotate if box is locked).
- Lift to open.

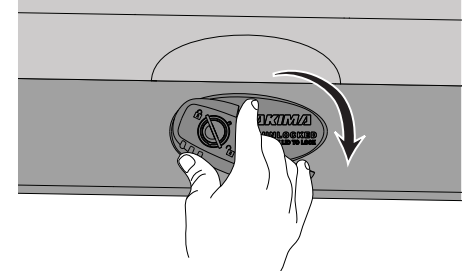
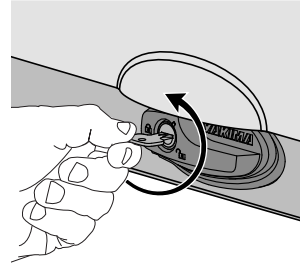

2

Lid will open both ways for ease of installation.

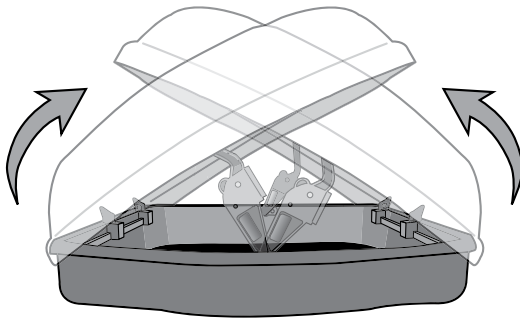

- Latches must be engaged before opening other side.
- Box should only be opened one side at a time.

INSIDE THE BOX:

3

Open levers all the way to lower clamps.

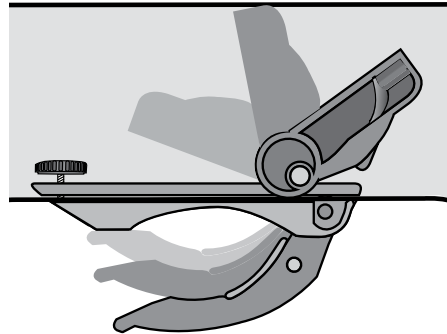

4

Loosen track thumb wheel 1/2 turn. Do not remove wheel.

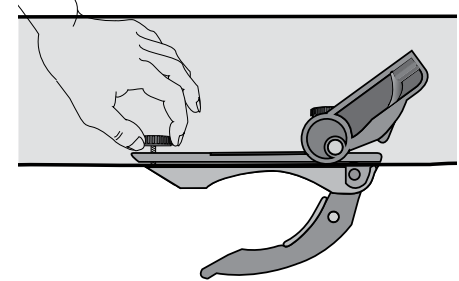

REMOVING THUMBWHEELS WILL CAUSE DISASSEMBLY OF LEVER/CLAMP MECHANISM.

LOAD CARGO BOX ONTO VEHICLE:



If your vehicle has a fairing, you must remove it if there is any interference.

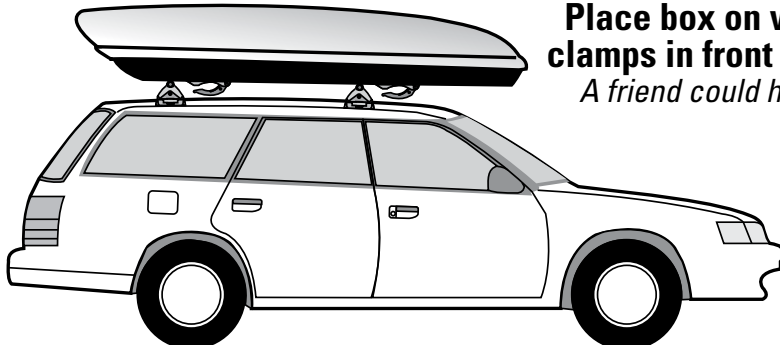

5

Place box on vehicle with clamps in front of crossbars.
A friend could help with this.

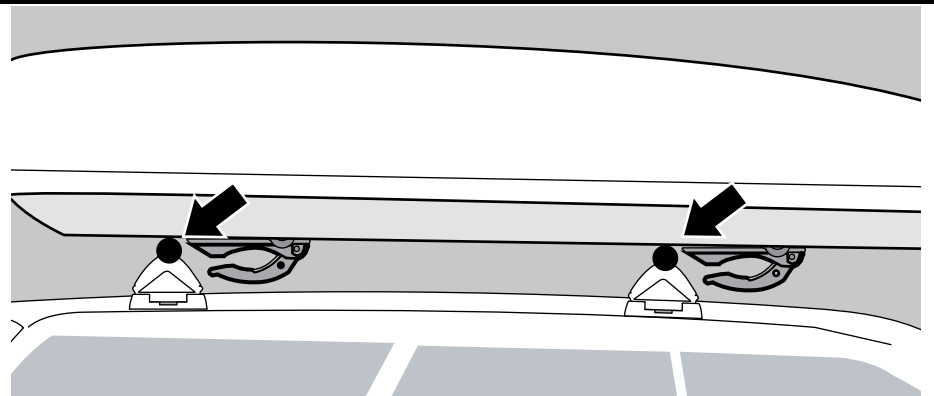

6 Open lid to gain access to levers.

Slide clamps along tracks (inside box) to engage crossbars.

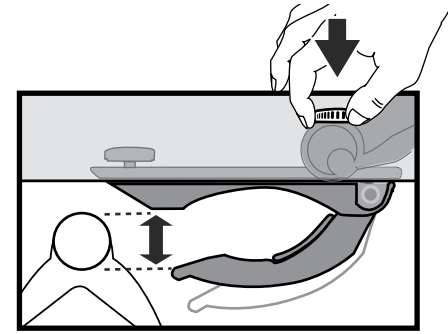
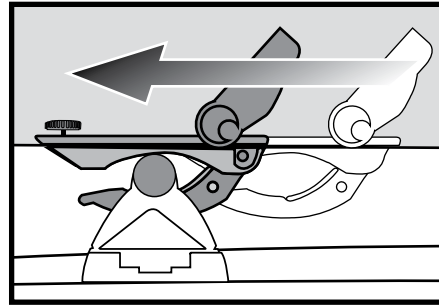
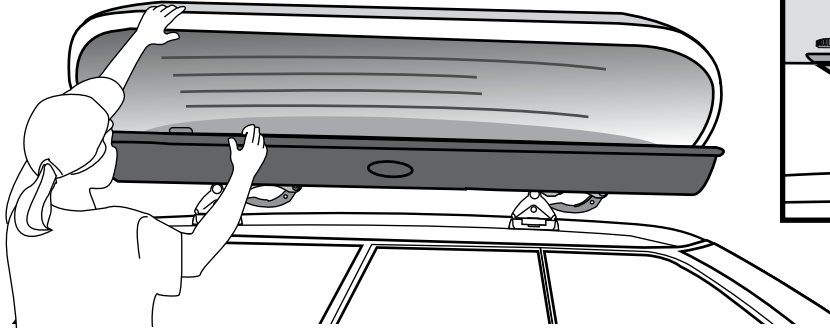

- Check clamp opening for crossbar clearance.
- Loosen clamp thumb wheel if necessary.

7 Adjust box position, checking for good alignment.

Always position box to avoid interference with rear hatch or sunroof.

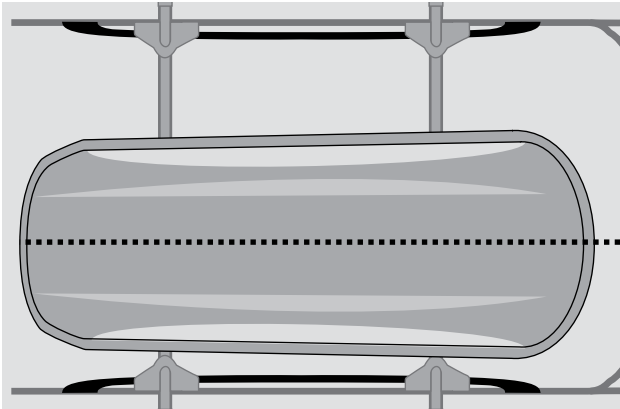

On some vehicles, hatch interference is unavoidable. Use caution when opening your hatch.



8

Close levers to engage clamps.

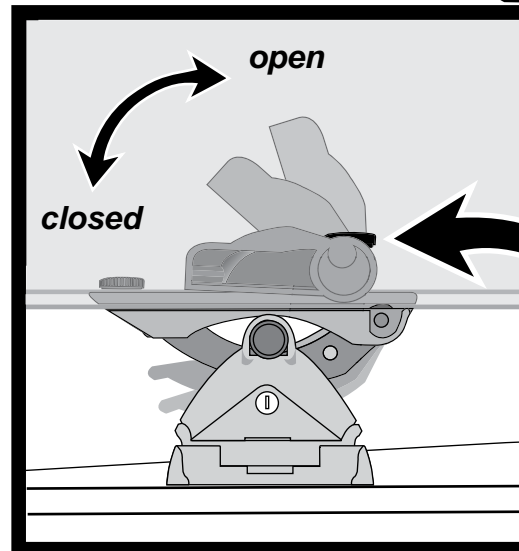

Tighten clamp thumb wheels until the levers close with firm resistance.

9

TIGHTEN ALL THUMB WHEELS.

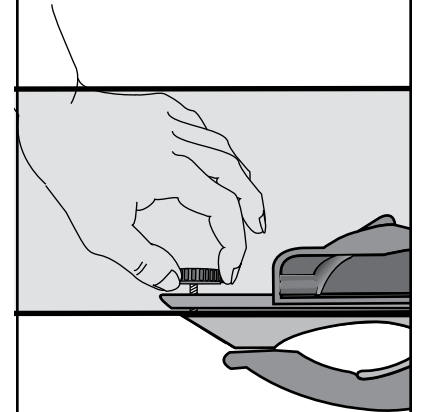

10 Close the box...

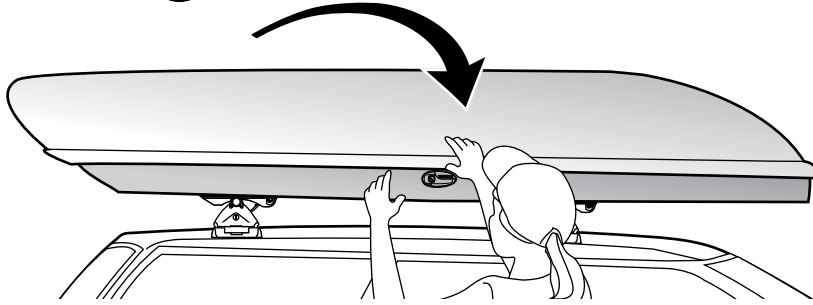

Push the lid down until the handle returns to a horizontal position.



Handle must return to the horizontal position to lock box and remove key.

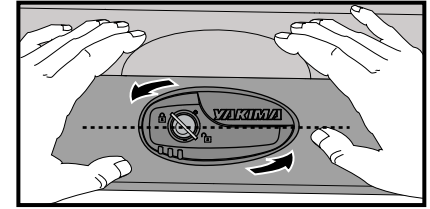
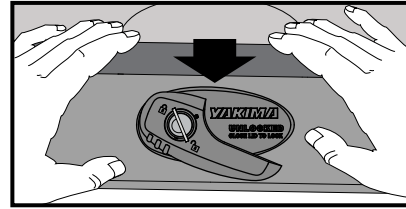

11 CHECK THE CLOSURE—PUSH UP ON LID.

Check that box is closed by
LIFTING UP AT BOTH ENDS.

CAUTION:
*Overstuffing the box
may prevent a secure closure.*

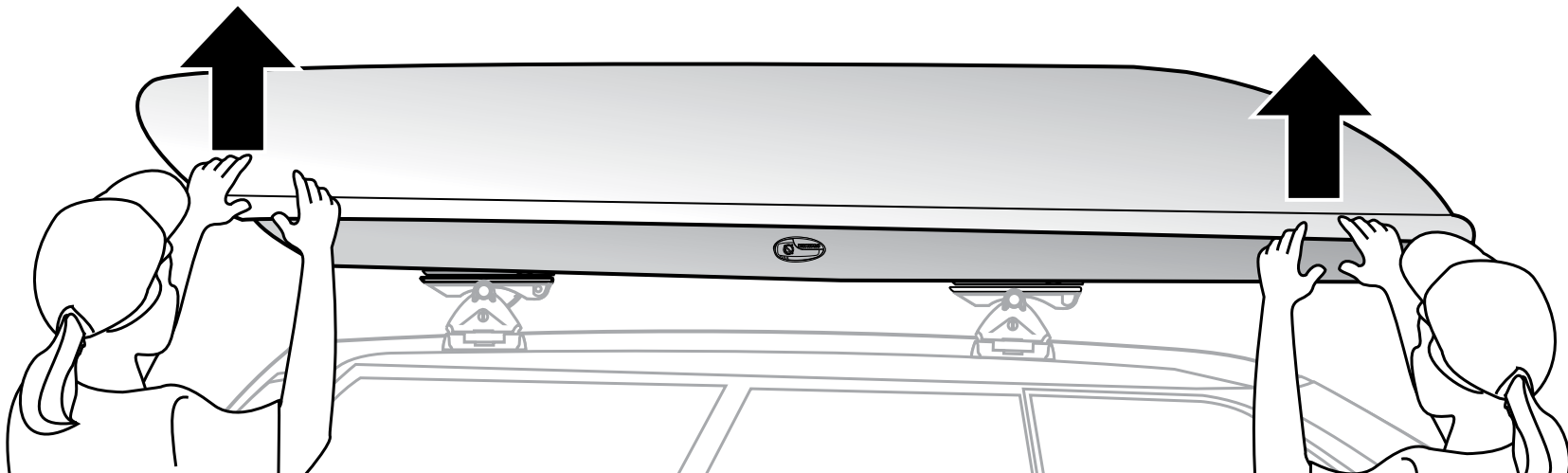

13 CHECK INSTALLATION BEFORE DRIVING AWAY

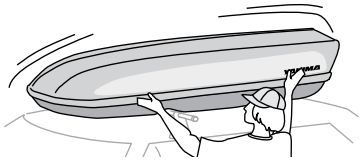

Make sure installation is secure by tugging at box.

- The box should not slide on the bars.
- Open the box and tighten levers if necessary.

CENTER HEAVIER LOADS IN THE CENTER OF THE BOX.

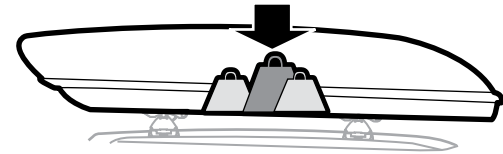

ALWAYS SECURE THE LOAD INSIDE THE BOX.

Use tie-down locations in rails.

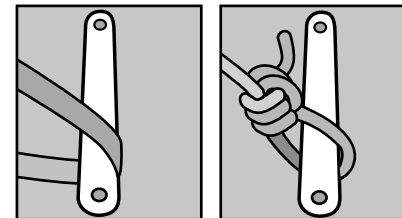

To lock...

- Turn key clockwise.
- To unlock, insert key and turn key counterclockwise.

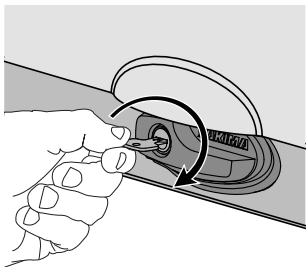

NOTE: Box must be closed and handle in horizontal position in order to lock box and remove key.

To replace lock core...

- Close box.
- Insert key and turn it to 45° counter clockwise. Remove key.

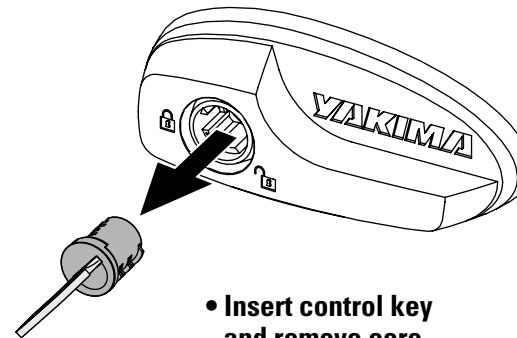
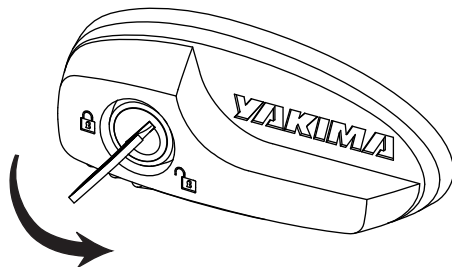

- Insert control key and remove core with control key.

- Install new lock core. Follow instructions that came with your lock core purchase.

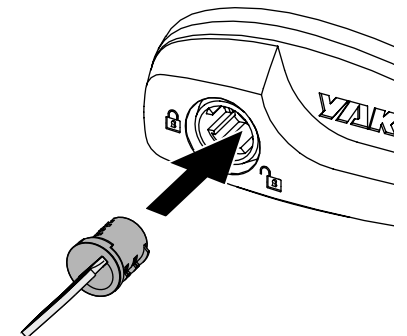

TO REMOVE CARGO BOX:

- Do not remove or adjust thumb wheels.
- Simply raise levers and remove box from crossbars.

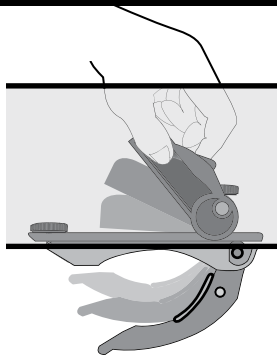

TO REINSTALL:

- With gear box adjusted to your vehicle, simply reload onto car, close levers and check for tightness.



To retain the adjustments for your vehicle, leave thumb wheels tightened.

REMOVING THUMBWHEELS WILL CAUSE DISASSEMBLY OF LEVER/CLAMP MECHANISM.

CARE AND MAINTENANCE

YAKIMA cargo boxes should be cared for and maintained, especially in extreme weather conditions.

- To clean, use only mild detergents. Harsh detergents could damage the gear box surface.
- Protect your gear box from extreme temperatures, (heat or cold) during prolonged storage.
- Remove gear box before entering automatic car wash.
- Hardware such as locks should be lubricated with graphite or other dry lubricant.

CAUTION

IF YOUR VEHICLE HAS A REAR HATCH:

On some vehicles, hatch interference is unavoidable.

Use caution when opening your hatch.

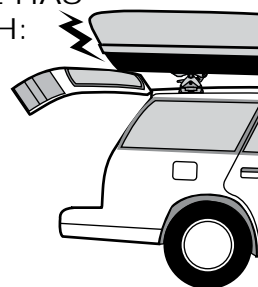

If your vehicle has a fairing, you must remove it if there is any interference.

READ THESE WARNINGS!

Periodically check the levers inside the box and tighten if necessary.

ATTACHMENT HARDWARE CAN LOOSEN OVER TIME. CHECK AND TIGHTEN IF NECESSARY, BEFORE EACH USE.

BE SURE ALL HARDWARE IS SECURED ACCORDING TO INSTRUCTIONS. FAILURE TO PERFORM SAFETY CHECKS BEFORE DRIVING AWAY CAN RESULT IN PROPERTY DAMAGE, PERSONAL INJURY, OR DEATH.

KEEP THESE INSTRUCTIONS