

LoadWarrior Extension

YAKIMA

Carry gear in the basket, and attach accessories directly to the LoadWarrior (using accessory instructions).

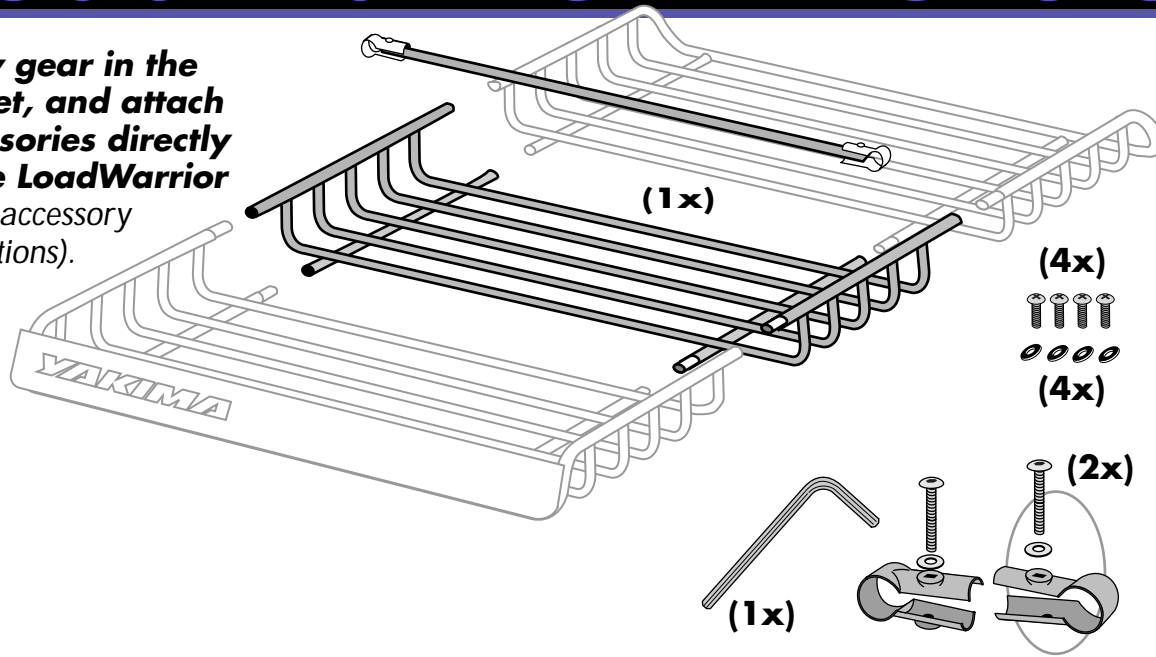

US

LOAD LIMITS:

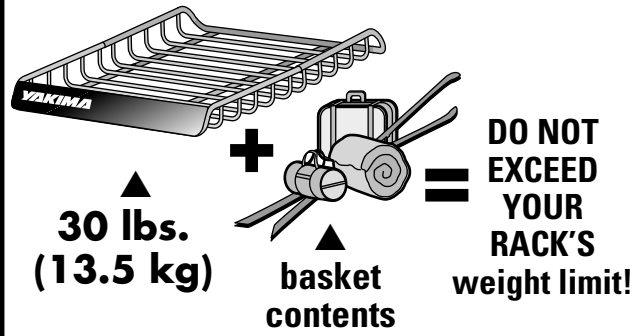

DO NOT EXCEED BASKET CONTENT WEIGHT LIMIT: 140 LBS. (63 KG)

1 IF YOU ALREADY HAVE A LOADWARRIOR INSTALLED:

- Remove it from your car.
- Disassemble the brackets and set them aside.
- Separate the two basket halves by removing the screws at the joints.

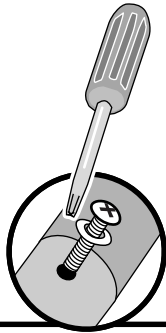

2 Remove the machine screws from the ends of the Extension tubes. • Insert the LoadWarrior Extension.

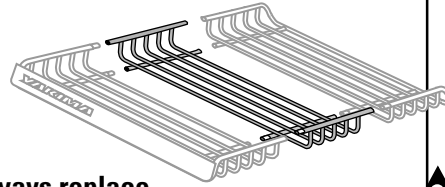
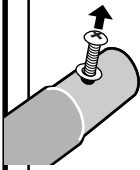

NOTE: Always replace machine screws (from Extension) into same holes when reassembling.



You may find tapered screws with your LoadWarrior.

MACHINE SCREWS



TAPERED SCREWS



DO NOT insert the tapered screws from LoadWarrior into your Extension's holes.

3

Insert correct screws into each of the joints and tighten them.

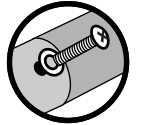

4 • IF YOU HAVE FIXED BARS:

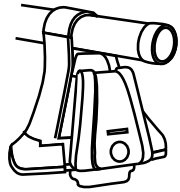

IF YOU HAVE "Q TOWERS"
OR BARS THAT CANNOT MOVE...

Continue to STEP 5.

- IF YOUR BARS MOVE:
IF YOU HAVE BARS THAT CAN BE MOVED...
Move the bars apart to a range of 30" to 50".

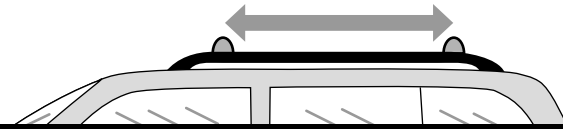

**Q TOWER OWNERS:
NEVER REPOSITION THE Q TOWERS!**



**TIGHTEN YOUR CROSSBARS
IF YOU LOOSENED THEM.**

5 LOAD BASKET ONTO RACKS. Center basket over your rack's crossbars.

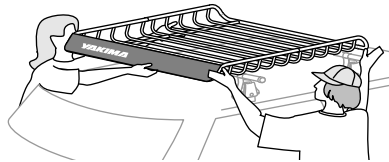

A friend would make this easier.

6 ATTACH BRACKETS TO BASKET SECTIONS ONLY. For first time bracket installation, refer to LoadWarrior instructions.

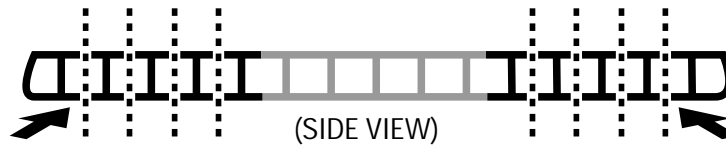

(SIDE VIEW)

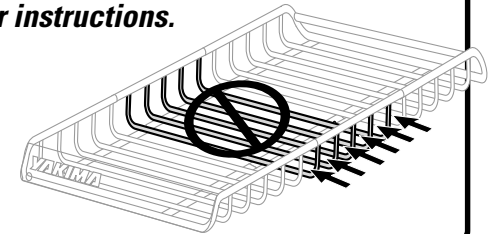

7 ATTACH BOLTS AND KNOBS. Insert bolts, engage the knobs.

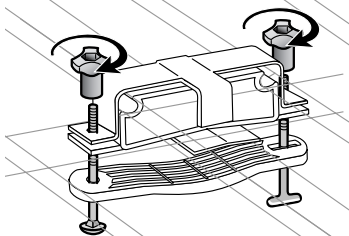

8 SECURE THE BASKET TO THE BARS. Lock the T-Bolts.

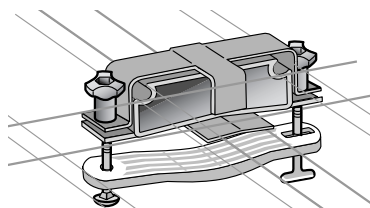

T-BOLT IS LOCKED when the "T" of the bolt is turned inside the hole:

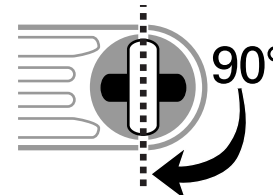

9 TIGHTEN THE KNOBS.

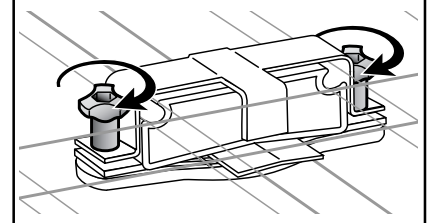

10 ATTACH LOAD BAR WITH END CLAMPS.

With a washer on the bolt, align the end clamps to the hole in the bar. Thread the bolts into the embedded nuts.

DO NOT COVER JOINT SCREWS WITH END CLAMPS.

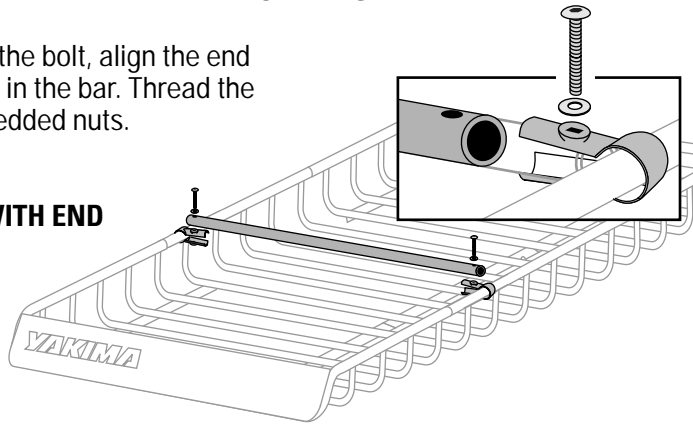
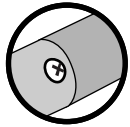

11 REFER TO THE DRAWINGS BELOW FOR BAR PLACEMENT, or to determine if the bar is required.

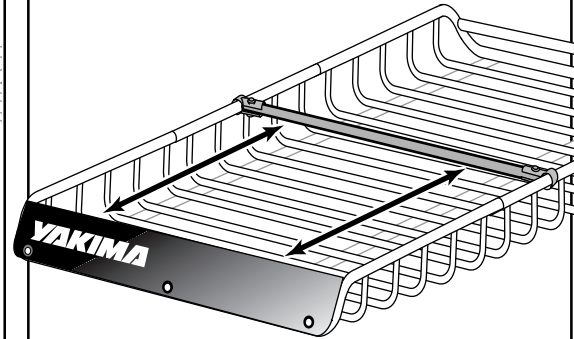

12 Tighten bolts while pushing the end clamps together.

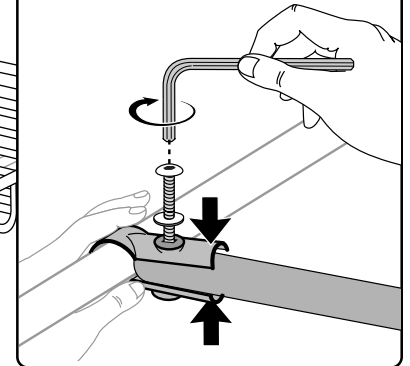

13 ACCESSORIES MUST BE ATTACHED TO THE FRONT OF THE BASKET (FRONT OF VEHICLE).

BIKES

- Attach carrier at front of basket and to load bar.
- Adjust the bar for load stability.

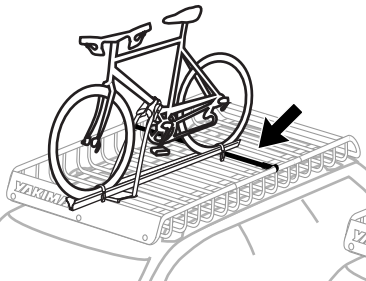

Upright carrier utilizing LoadBar

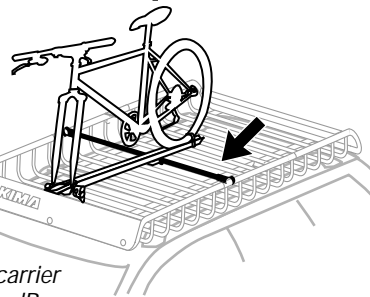

Fork style carrier utilizing LoadBar

BOATS

- For shorter boats, attach accessory at front of basket and to load bar.
- Longer loads, such as canoes or sea kayaks, require the load bar to be removed.

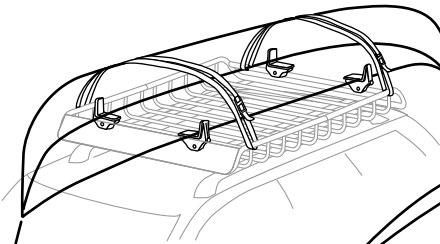

Long loads may interfere with LoadBar

SKIS

- Attach accessory at front of basket and to load bar.

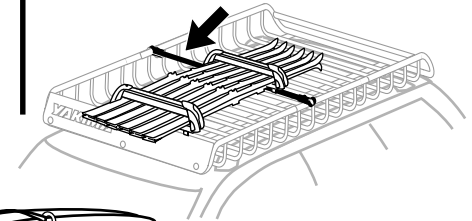

Short boat utilizing LoadBar

14 ALWAYS TIE DOWN LONG LOADS TO FRONT AND REAR OF VEHICLE.

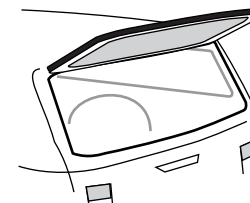
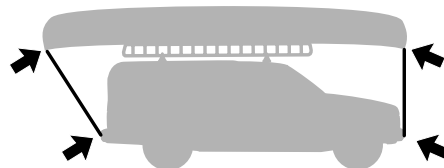

USE CAUTION WHEN OPENING YOUR HATCH.

On some vehicles, hatch interference is unavoidable.