

YAKIMA

SkyRise

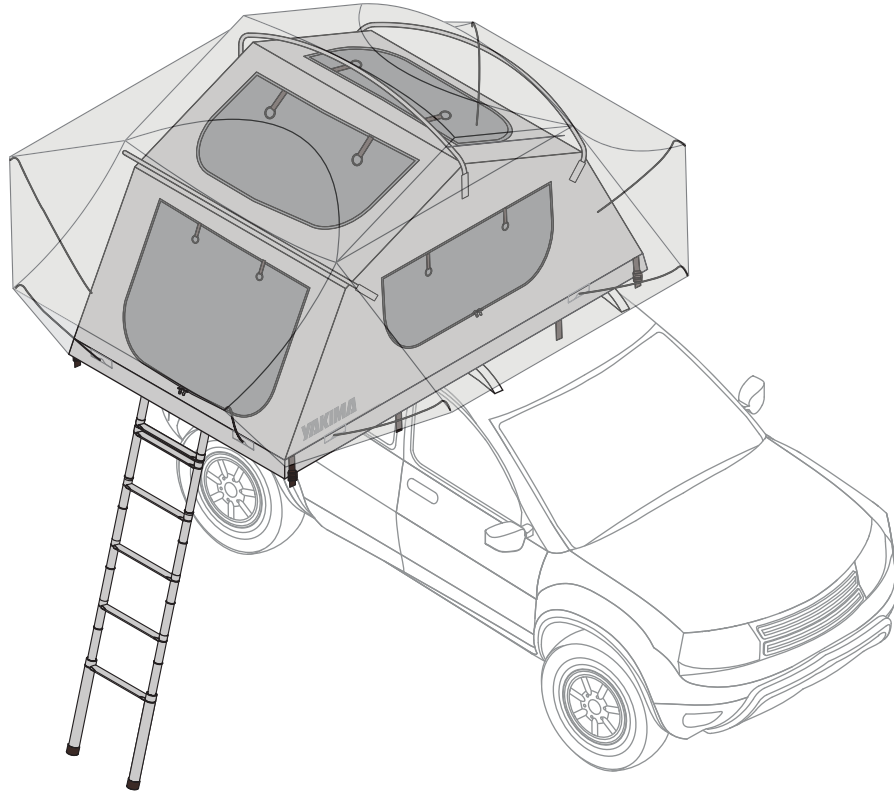

CONTENTS

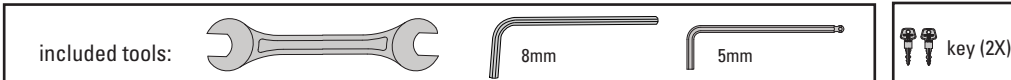
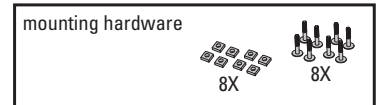
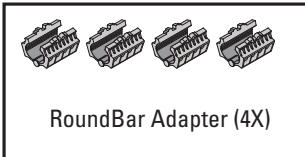
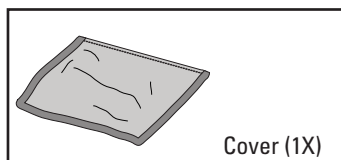
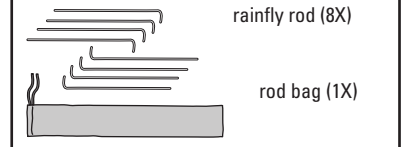
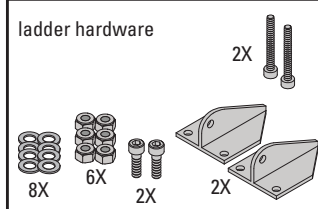
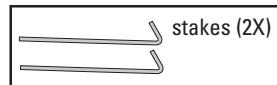
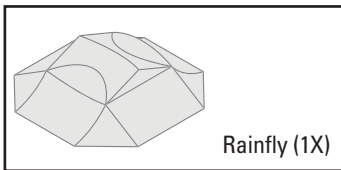
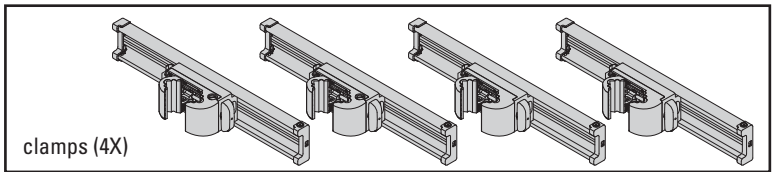
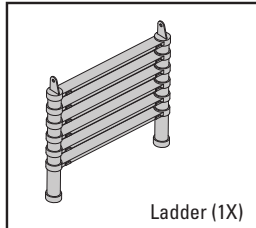
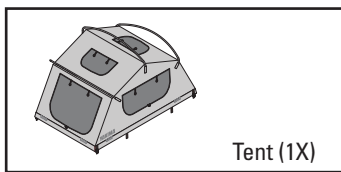

contents not to scale

READ ME FIRST!

FIRST OFF, THANKS!

Welcome to the Yakima family. We appreciate your support and are confident that you'll get years of solid performance from your new Yakima product. Below are a few helpful hints to make sure that you have a great ownership experience. Please keep these instructions.

WATCH
FOR
THESE
SYMBOLS!



=

SAFETY – Keep safe by reading the important safety warnings included in the product instructions! Safety warnings are identified with this symbol.

=

STOP – Please read all important product notes in the product instructions to ensure proper installation or fit information. These notes are identified with this symbol.

SOME DO'S AND DON'TS

(additional warnings are contained in these instructions)

- Do have a friend or dealer help with installation.
- Do use tent when parked on level ground.
- Do remove tent when not in use.
- Do dry tent before storage.
- Do use tent on level ground.
- Do close tent cover fully before driving away.
- Do assist children on the ladder.
- Do close and secure cover before driving.
- Do not climb on your vehicle's roof.
- Do not use tent unless ladder is securely in place.
- Do not allow more than one adult on the ladder at a time.
- Do not use tent in high winds or heavy snow.
- Do not transport anything on top of closed tent.
- Do not use open flame nor cook inside tent.

IMPORTANT FIT INFORMATION

WARNING - DO NOT USE THIS PRODUCT ON A VEHICLE THAT IS INDICATED AS "NO-FIT"

The Yakima Fit List now includes approved SkyRise fits for many popular vehicles. Updates and additions to the Yakima Fit List for rooftop tents are being made continually.

Vehicles that we have seen and tested are designated as "FIT" or "NO-FIT" for SkyRise. Fits for SkyRise are different than for other Yakima products. **Please note that virtually all factory crossbars are too flexible for rooftop tents. So vehicles approved in the Fit List will still require a Yakima roof rack system.** If we have not tested your particular vehicle and rack system, you can use the checklist below to evaluate whether your vehicle and rack system may support a SkyRise.

Remember: The checklist below is designed to be a guideline only and any installation not on our approved Fit list is at the sole risk and responsibility of the owner / installer.

- Vehicle and rack system have a minimum load carrying capacity of 165 lbs.
- The following Yakima towers are being used: TimberLine, SkyLine, RidgeLine, RailGrab (med. or large claw), ControlTower, LowRider, 1A RainGutter, BedRock, and Outdoorsman.
- Use with Yakima RoundBar, CoreBar, or JetStream bars
- For factory tracks or fixed points (see figure 1), ensure roof does not deform when heavy loads are applied
- For vehicles with raised rails, position crossbars as close as possible to rail supports
- Crossbar spread is between 26" and 40.5"
- Do not use rooftop tent with any clamp type towers (including Q-Tower and BaseLine) or RailGrab Towers with Small Claw or Pin Adapter.
- Do not use with factory crossbars, they are too flexible
- Do not position mounting hardware more than 1" outside of Tower (see figure 2).
- Max distance from top of crossbar to top of ground; SkyRise Small = 86", SkyRise Medium = 98"
- Do not install on cantilever rails, or rails without sufficient support (see figure 3).

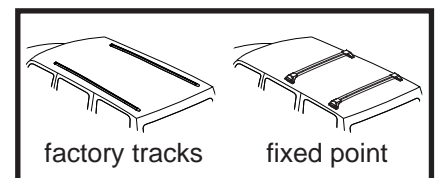

fig. 1

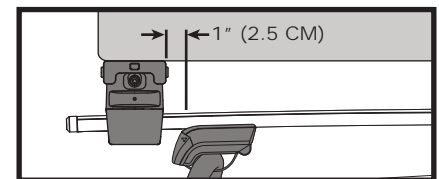

fig. 2

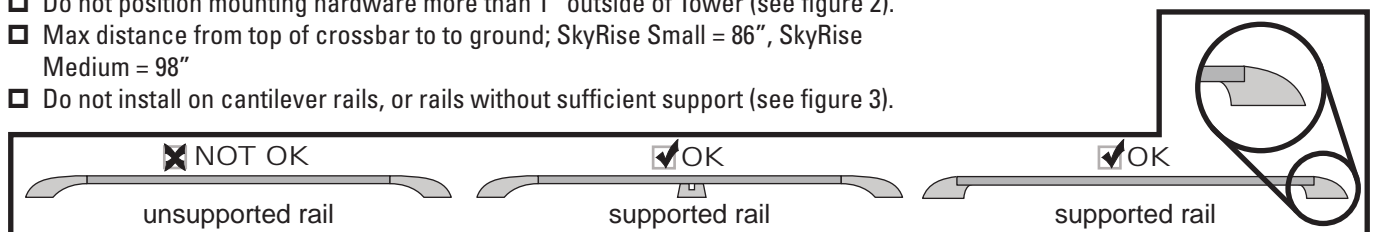

fig. 3

ASSEMBLE & INSTALL

1 **Remove contents from tent.** Remove the ladder, cover, rainfly rod bag, and mounting hardware box from inside.

2 **Open the tent.** Lift the side of the tent with the mounting holes into the vertical position, as shown below.

3 **Determine tent deployment direction.** Then identify the mounting holes for your deployment direction and use them in the next steps.

SIDE DEPLOYMENT

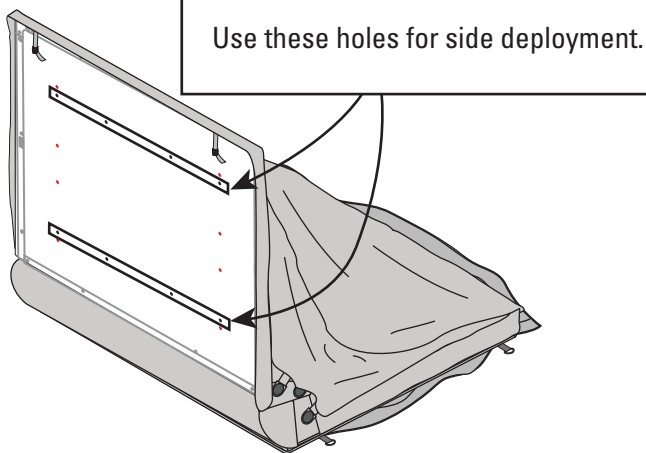
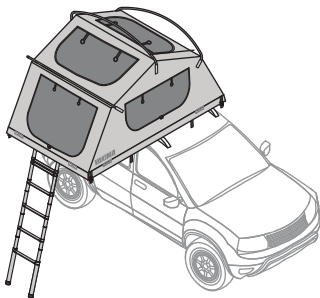

Puncture black stickers over the mounting holes you will use.

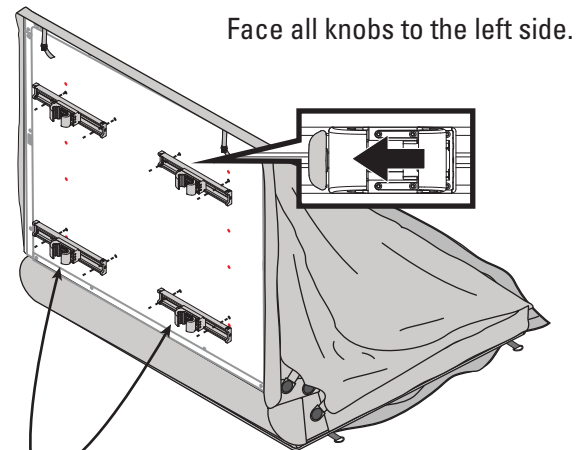

The locks should be on this side.

REAR DEPLOYMENT

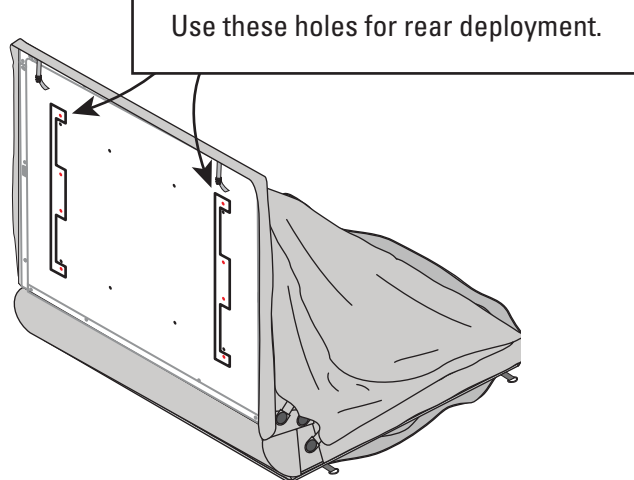
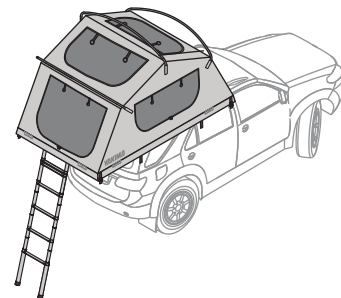

Puncture red stickers over the mounting holes you will use.

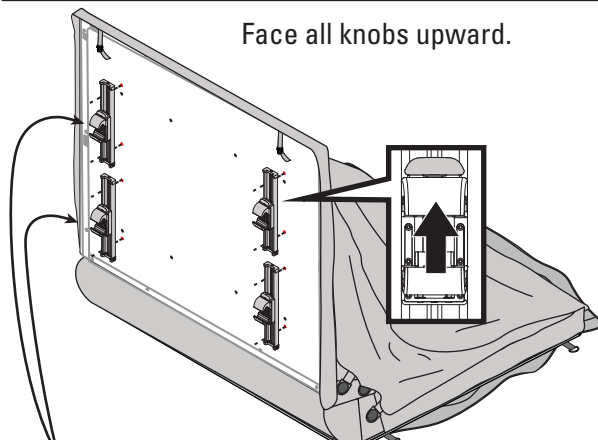

The locks should be on this side.

4

Prepare mounting clamps.

Using the 5mm hex wrench loosen slider bolt.

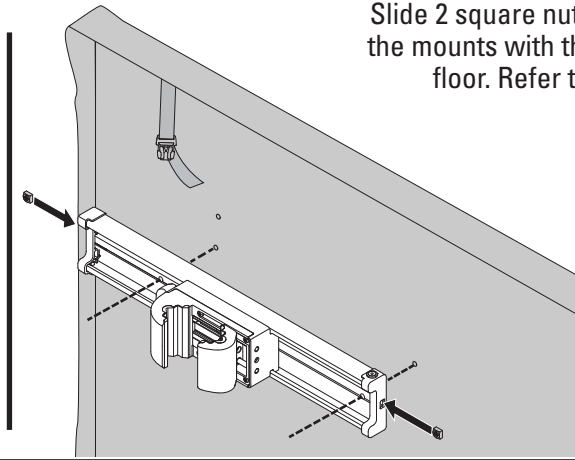
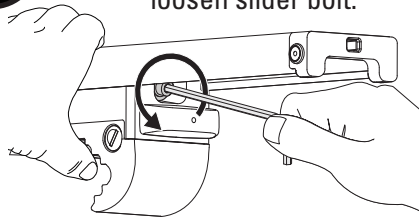

Slide 2 square nuts into each mount, and align the mounts with the predrilled holes in the tent floor. Refer to step 2 for orientation.

4X

5

Attach mounting clamps. Reach under the mattress and feed a bolt through the hole. Slide the square nut using the included 5mm hex wrench to align it with the bolt end.

Hand tighten the bolt from inside the tent, then tighten the bolts down completely with the hex wrench.

TIPS

- Have a friend help hold the tent steady.
- Remove the mattress completely for easier access to the holes.

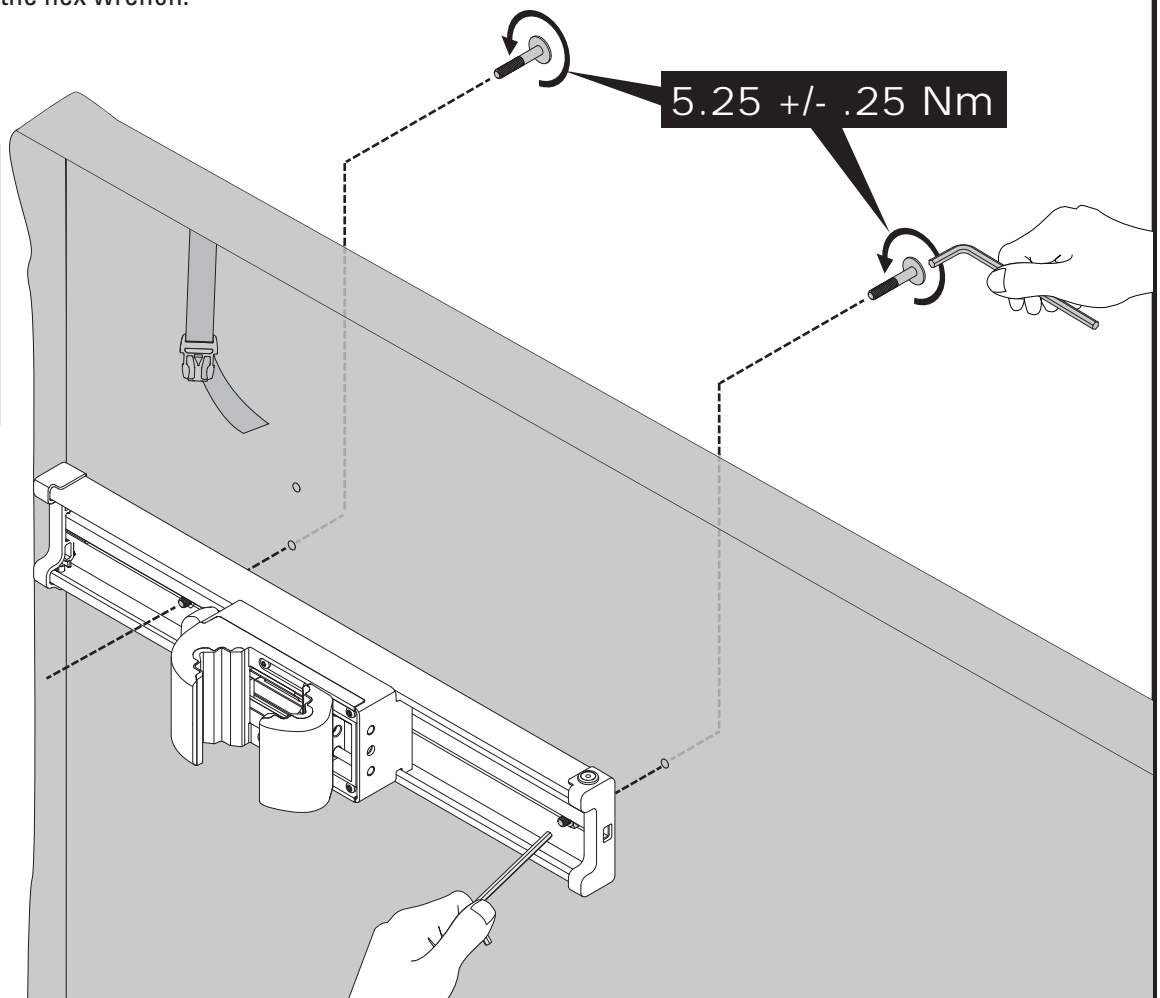

5.25 +/- .25 Nm



Be sure knobs all face same direction and locks are on same side facing outboard (refer back to mounting setup in step 2).

4X

6

Attach ladder brackets. First flip SkyRise over to rest on the clamps. Locate the predrilled holes under stickers near the edge. Remove the stickers.

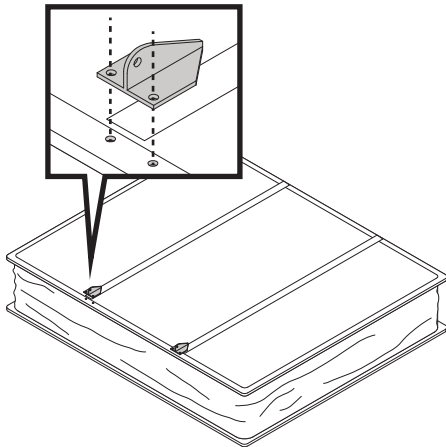

Orient the brackets as shown. Reach under the mattress and insert two of the long bolts with washer up through the floor and bracket. Hand thread a locknut onto each bolt. Then, using the 8mm hex wrench and included 13mm open ended wrench, tighten the bolts.

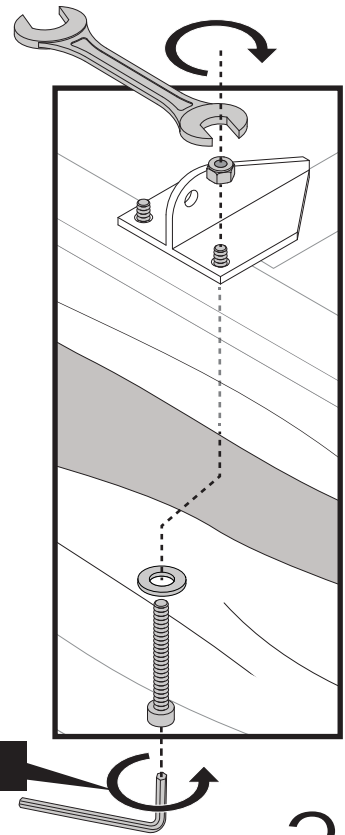

5.25 +/- .25 Nm

2X

7

Attach the ladder. Make sure information stickers are visible, and the top brackets are **FLAT EDGE DOWN**. Secure the ladder with two short bolts, four washers and two lock nuts using the 8mm hex wrench and 13mm open ended wrench. **BE SURE BOLTS ARE FULLY TIGHTENED!**

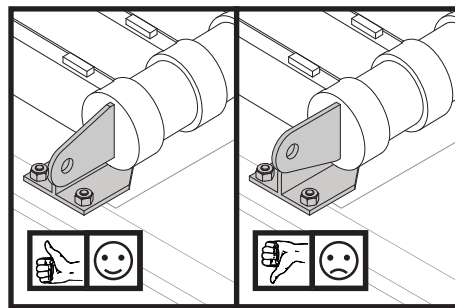

2.75 +/- .25 Nm

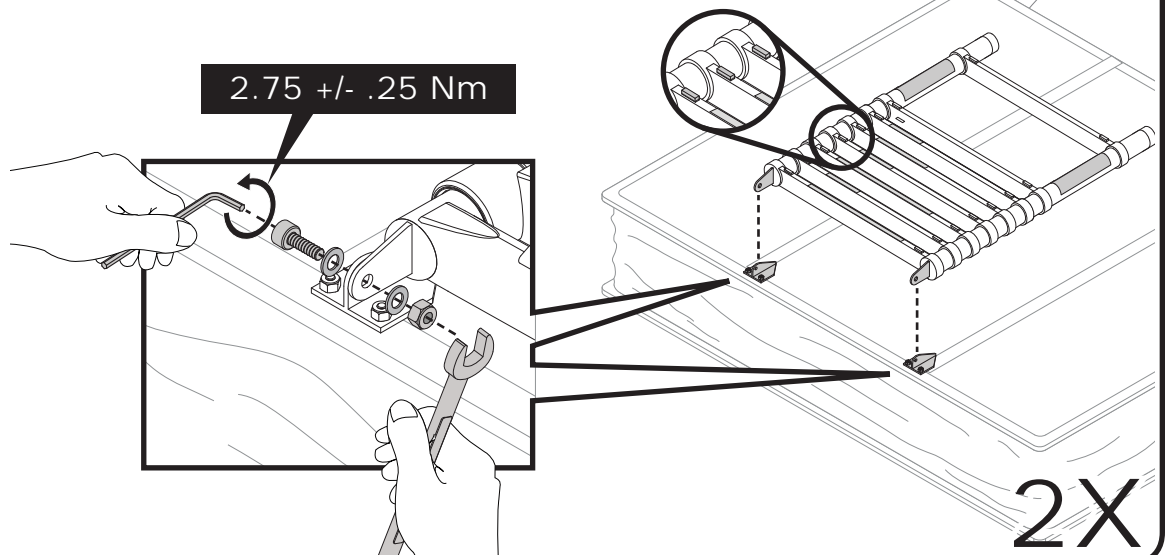

2X

8

Install the cover.

- A. Slide the cover (hook and loop fastener side up) into the round channel.
- B. Secure tent with its hook and loop fastener ties, being sure not to over tighten.
- C. Put the cover on, secure the buckles and zipper closure.

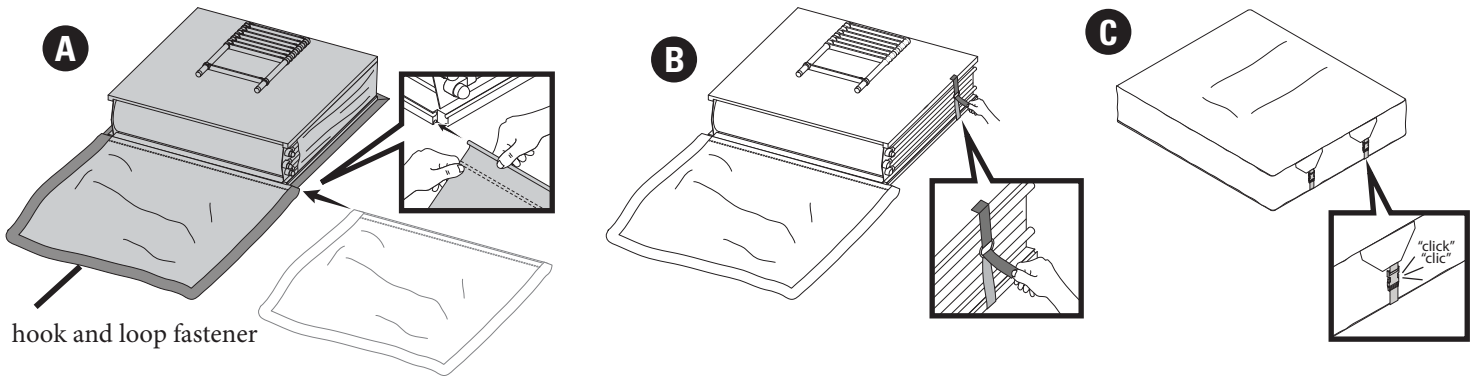

hook and loop fastener

9

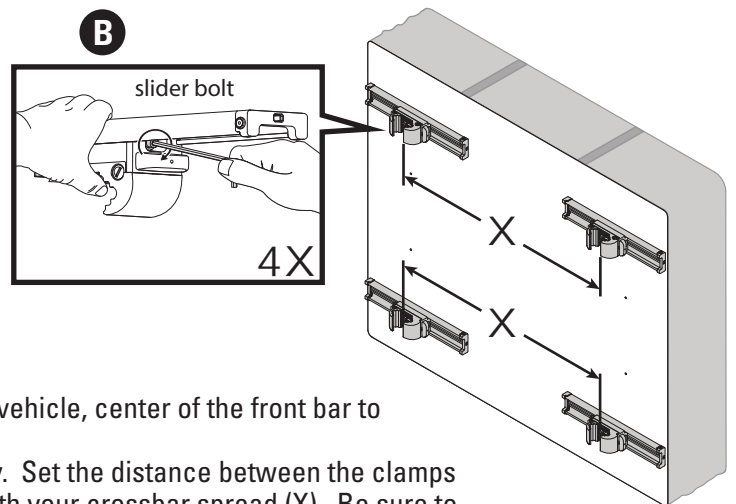
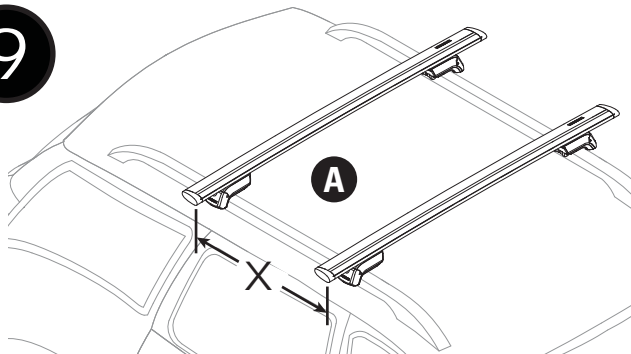

Prepare the tent for vehicle installation.

- A. Measure the distance (X) between the crossbars on your vehicle, center of the front bar to center of the rear bar.
- B. Tilt SkyRise up on its side. Open all the clamps completely. Set the distance between the clamps by sliding them along their tracks so they will match up with your crossbar spread (X). Be sure to measure from the **fixed side of the clamps** (X). Once set, partially tighten all SLIDER BOLTS.



If you have Yakima RoundBars you must use the included RoundBar adapters. The adapters go around the RoundBars, and the clamps fit over the adapters. Make sure to remove the rubber pads from the clamps.

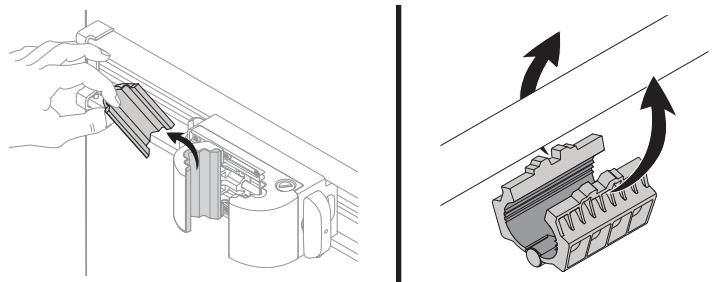

10

Install the tent on your vehicle. Have a friend help you lift the SkyRise onto your vehicle's crossbars.

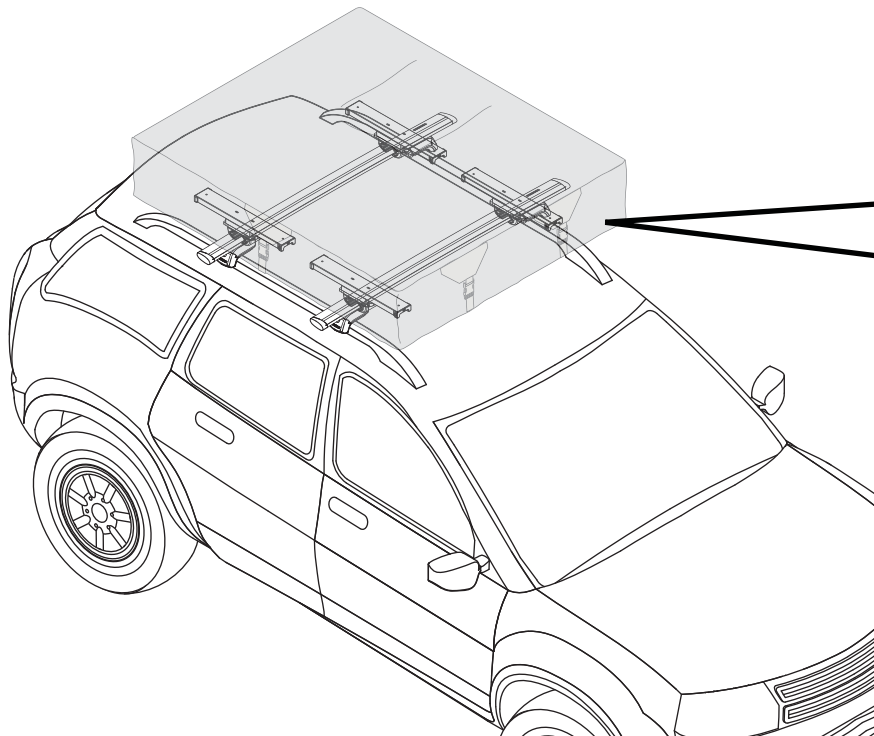
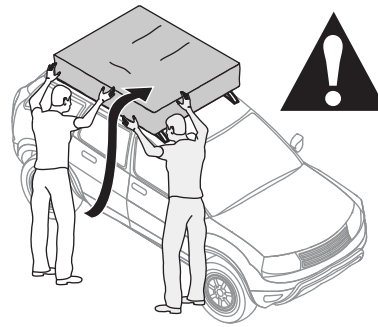

A

Tighten the clamps around your crossbars.

4X

B

2.75 +/- .25 Nm

Fully tighten the slider bolt on each clamp.

4X

C

Lock the clamps.

2X

!

Clamp must seat correctly onto bars, or tent can slide on crossbars.

!

Test Install - retighten as necessary.

You are now ready to travel to your campsite!

11 Find a level place to park.
Apply your parking brake.

12 Remove and secure the cover.
Unzip and unbuckle the cover, fold it forward, then roll it up and secure it with the ties.

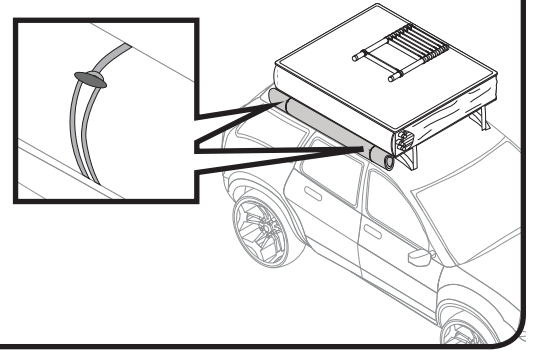

13 Deploy the tent and set the ladder.

First release the strap then grasp the ladder from the bottom rung and pull it to extend the ladder out.

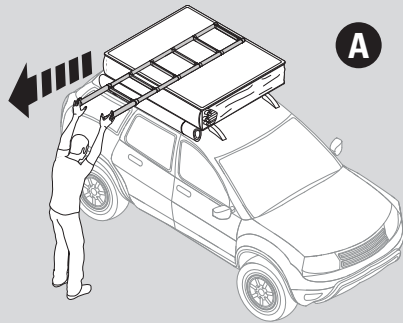

Push down on the ladder and walk backwards a couple steps. This will force the SkyRise to fold out and open up.

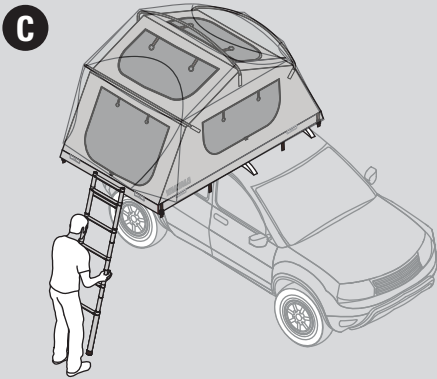
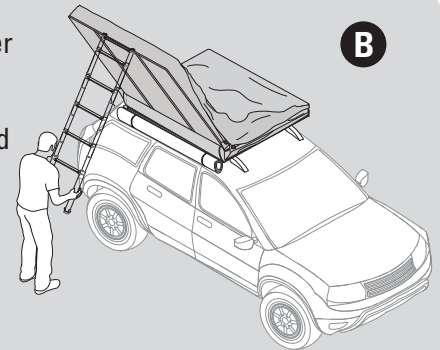

With a secure grasp on the ladder, use it to fully lower the SkyRise until it's open, and the floor of the tent is flat. Rest the feet of the ladder on the ground.

- D**
- Make sure the top rung is locked out in one of the 3 positions (Listen for a "click" as each rung locks into place).
 - Adjust the ladder so that the tent platform is level.
 - The ladder angle must be between 90 and 75 degrees
 - Unused rungs should be stacked under the top step of the ladder.
 - **SkyRise is not compatible with ladder extensions.**

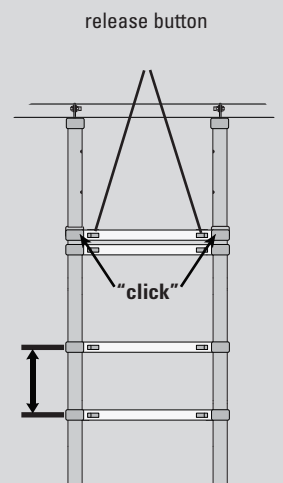

- Ladder must remain in place to support tent - do not retract while in use.
- Read and follow warnings on ladder, and use caution climbing ladder.

14

Set up the rainfly.

The easiest way to deploy the rainfly is from within the tent. With the rainfly attached to the tent climb inside, and open the doors and side windows.

Reach through the side windows and find the 2 flaps on each side of the tent. Place the straight ends of 4 rods into the holes beneath the side flaps, and hook the curved ends into the grommet holes on the rainfly.

Reach through the doors and find the 2 flaps on each end of the tent. Place the straight ends of the other 4 rods into the holes beneath the end flaps, and hook the curved ends into the grommet holes on the rainfly. **Rods are under tension when installed. Do not be directly under a rod while installing or removing.**

The rainfly is removable. It can be detached from the tent by unhooking the buckles and lifted away with the rainfly hoops.

In windy conditions, use included ground stakes and tie downs to anchor your SkyRise. Tie them to D rings found on the frame as shown below.

Use this SkyRise Medium image as a guide.

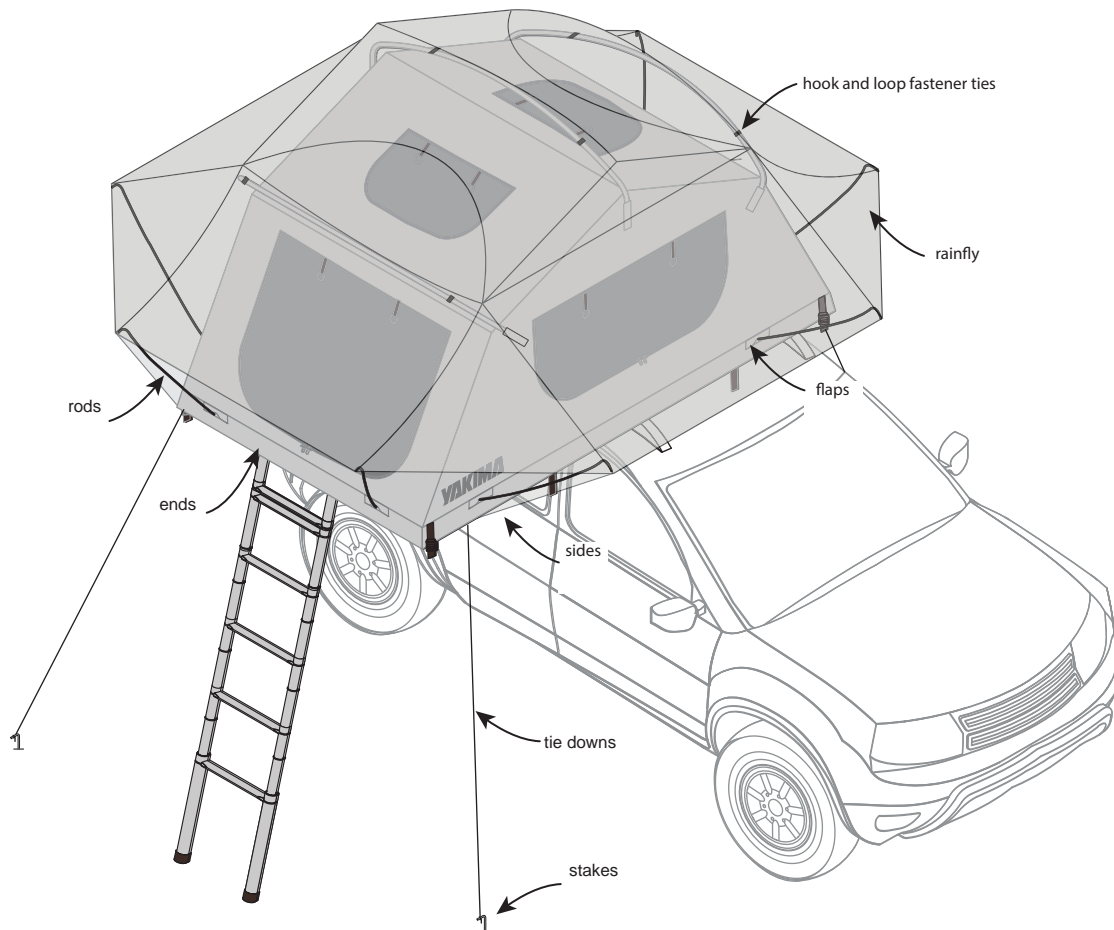

CLOSE & SECURE



Never operate your vehicle with the SkyRise open! You must close and secure your SkyRise before driving.

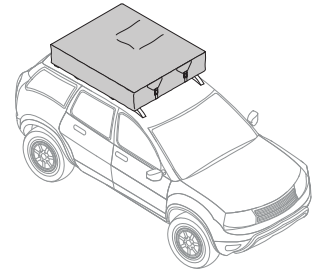
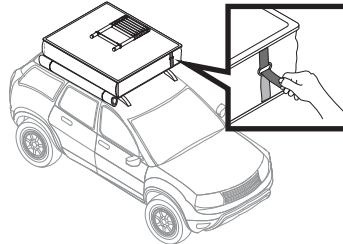
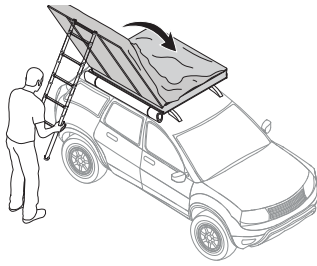

Use the ladder to fold the tent back onto itself. Collapse the ladder and fully retract it. Secure the hook and loop fastener straps. Unroll and replace the protective cover, zip it closed, and buckle it up.

REMOVAL

1 Unlock the clamps.

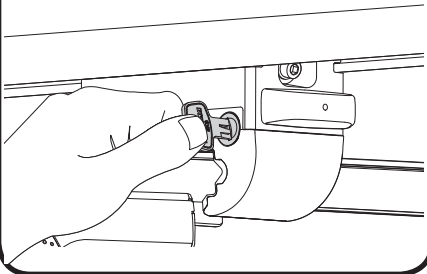

2 Fully open clamps.

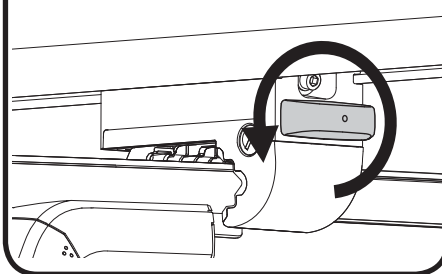

3

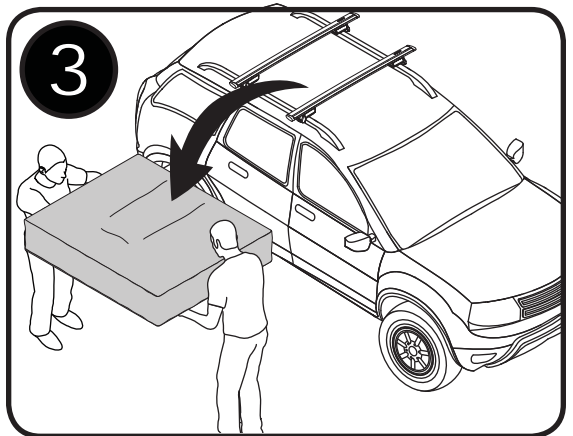

WEIGHT LIMITS



Do not exceed vehicle's weight limits.

Tent Weight

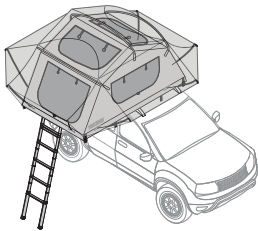

SkyRise Small 95 lbs (43 Kg)
SkyRise Medium 115 lbs (52 Kg)
SkyRise HD Small 100 lbs (45 Kg)
SkyRise Medium 120 lbs (54 Kg)

Maximum Tent Capacity

Small: 400 lbs.
Medium: 600 lbs.

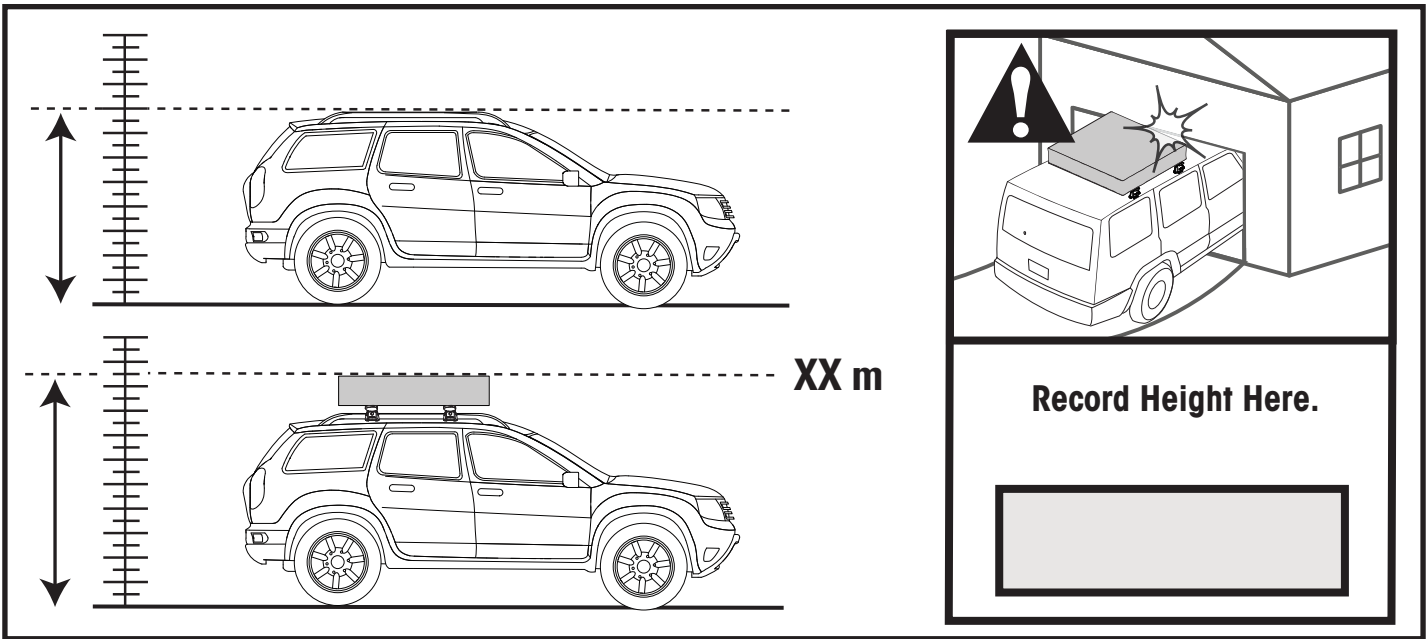

IMPORTANT WARNINGS

- Remove your tent and Yakima Rack before entering an automated car wash.
- Do not use fuel burning, oxygen consuming devices inside the tent. This includes: candles, gas lanterns, kerosene lamps, stoves, cooking and heating appliances.
- Do not pitch the tent near a camp fire or any other flame source.
- Inspect mounting hardware of tent before driving away.
- Never extend ladder beyond predrilled holes and factory locking position.
- Do not drill additional holes into the ladder.
- Ladder angle must be between 90 and 75 degrees.

Rack Installation

Improperly mounted roof racks and tents can come loose during travel and cause serious accidents! Installation, handling and use must be carried out in accordance with product and Roof-Rack instructions.

Check attachment hardware and load for tight fit and function:

- Before driving away.
- After driving a short distance, following tent install.
- At regular intervals on longer trips.
- Every two hours on bad terrain.

Vehicle Driving and Regulations

The speed driven must be suited to the load transported and to official speed limits.

When transporting any load, the speed of the vehicle must take into account all conditions such as the state of the road, the surface of the road, traffic conditions, wind, etc. Vehicle handling, cornering, braking and sensitivity to side winds will change with the addition of roof top loads.

Rooftop Tent Care and Maintenance

Your Rooftop Tent is designed to be a durable companion on your adventures. In order to keep it performing at its best, we recommend some simple care and maintenance steps that will help prolong the life of your Rooftop Tent.

- Prior to each use, inspect your Rooftop Tent mounting hardware. If necessary, clean with a solution of mild detergent and water. Periodically lubricate the threads on your hardware with a light synthetic bicycle lubricant to maintain performance.
- Dry your Rooftop Tent thoroughly before you close it. If unable to properly dry your Rooftop Tent prior to closing, open it up and air dry it at your next opportunity. Failure to properly dry your tent out can lead to the growth of mold and mildew which can degrade the tent material, cause discoloration, and foul odor. Mold and mildew growth is not covered under your Rooftop tent warranty.
- Proper storage of your Rooftop Tent when not in use will prolong the life of your tent. Ensure it is fully dry prior to storage and store in a cool dry location free from direct sunlight.
- Zippers should be pulled with even force and in gentle fashion. Never force a zipper open or closed as it may damage your zipper. Keep your zippers free from dust and dirt and periodically apply non-scented bees wax to the zipper teeth as lubrication. This will prolong the life of your zippers.
- Ladder should be wiped free of any dirt or dust prior to collapsing the tent. Periodically wipe down the aluminum telescoping side rails of the ladder with silicone spray and a cloth. DO NOT spray silicone spray directly on the ladder tread surfaces.
- Keep your mattress dry and free from dirt. Prior to closing your Rooftop tent lift your mattress and ensure the underside is dry. Remove mattress and air dry if necessary. To clean mattress cover, remove cover and machine wash gentle cycle with Woolite™ detergent. Hang dry, DO NOT TUMBLE DRY.
- To clean your Rooftop Tent use a mild detergent and warm water gently applied with a sponge. Rinse with a clean wet sponge and allow to thoroughly dry.
- If mildew and or mold have begun to grow on your tent, we recommend cleaning the affected tent fabric by sponging on a solution of 1 cup Lysol™ mixed in 1 gallon of hot water and allow to dry. Next, prepare a solution of 1 cup lemon juice concentrate and 1 cup salt in 1 gallon of hot water. Sponge this solution directly into the affected areas to rinse out the Lysol™ solution. Allow to air dry completely. Taking these steps will stop the growth of the mildew and help eliminate odor, however it may not completely remove the stains.
- Avoid excessive sun exposure to your tent to prolong the life of the fabric. Over time, UV rays can degrade tent fabric and water proof coatings. If your rain fly material begins to break down due to exposure and use, we suggest washing the fabric with mild detergent and water followed by a treatment of water repellent such as 303 Fabric Guard™. Consult your local outdoor store for other tent fabric care products and use as directed.