

# YAKIMA

## Skinny Warrior Extension

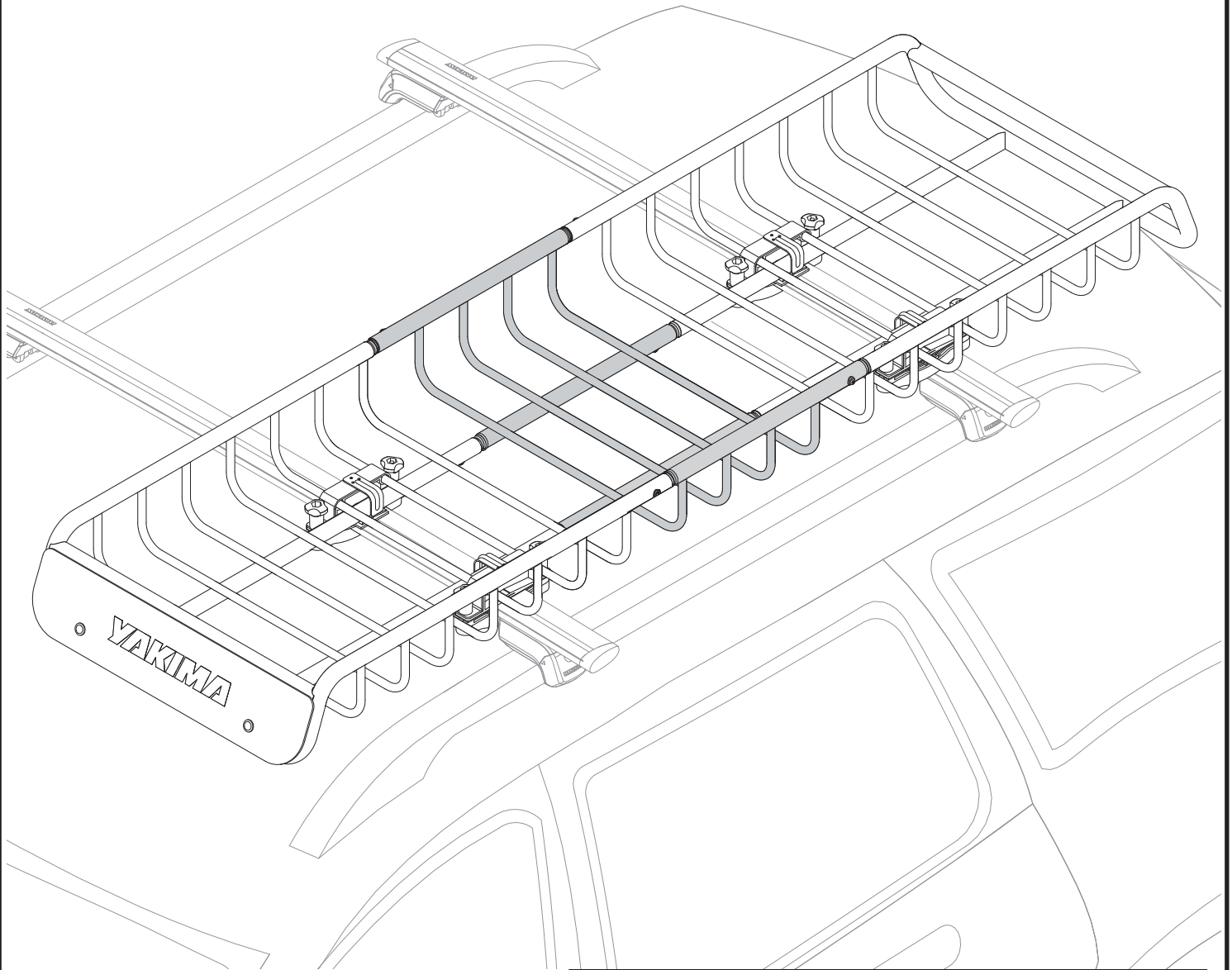

### Contents

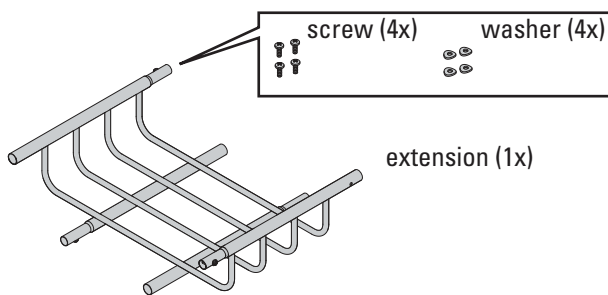

### Crossbar spread



### Tools required



## ASSEMBLE & INSTALL



*BASELINE AND Q TOWER  
OWNERS: NEVER  
REPOSITION THE TOWERS!*

1

**If you have already installed your SkinnyWarrior:**

Remove it from your car. Disassemble the brackets and set them aside. Then separate the two basket halves by removing the hardware at the joints. Set the hardware aside.

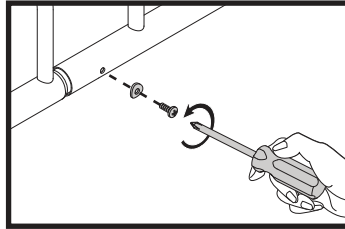

2

**Remove the hardware.** Use a screwdriver to remove the screws and washers from the ends of the extension.

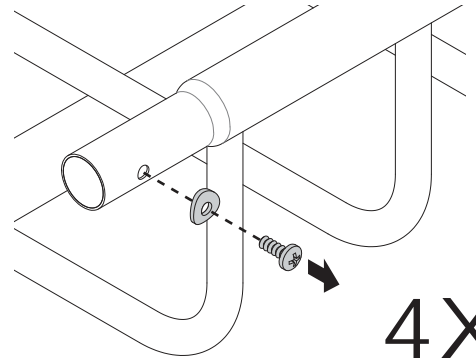

3

**Assemble the basket.** Insert screws *with washers* into each of the holes and tighten them.

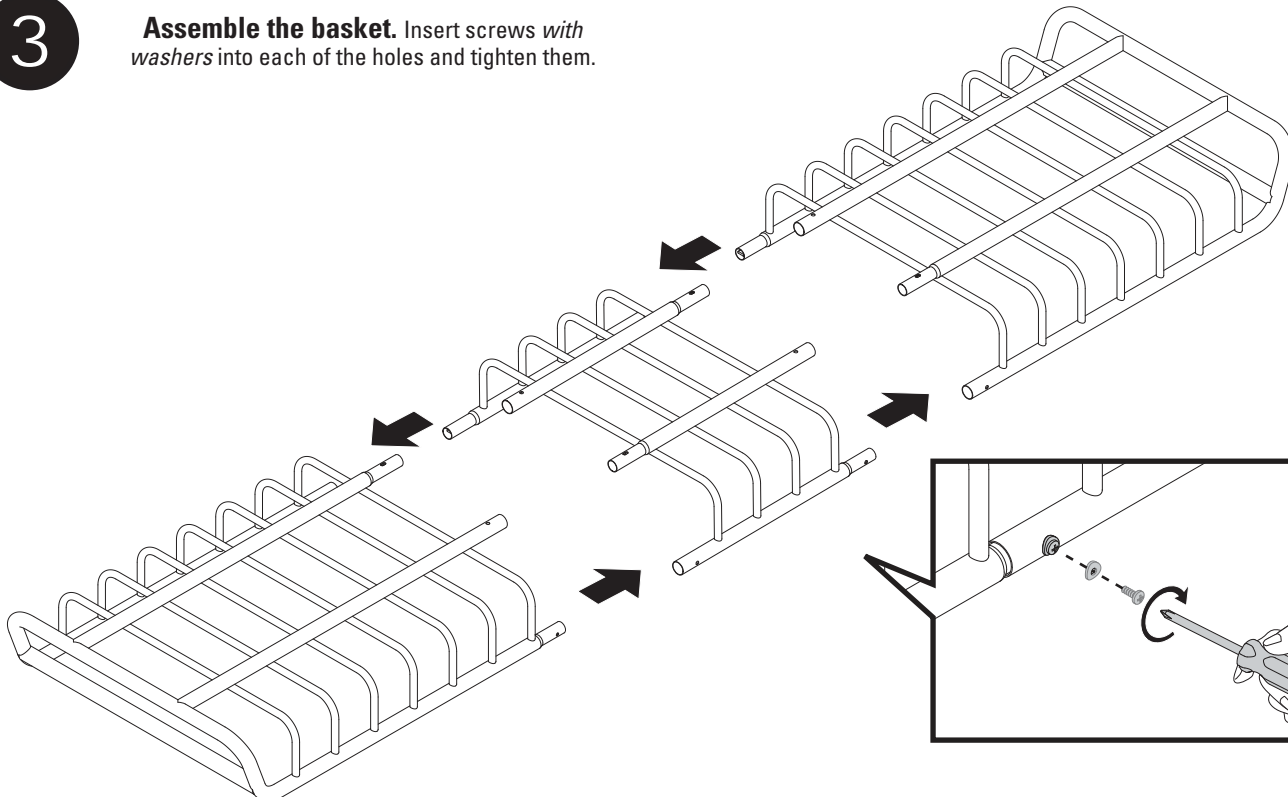

4

**Attach the support brackets.** Measure the distance between your crossbars and attach support brackets at that distance. Place the brackets **OUTSIDE** of the basket frame. The Tabs on brackets must face **INBOARD**.

**NOTE:** Press firmly and listen for "snap".

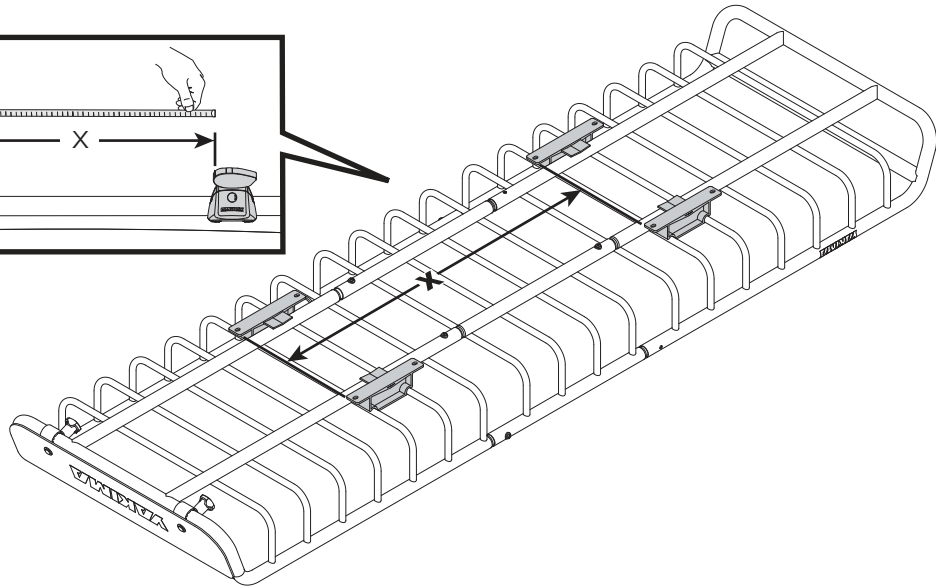
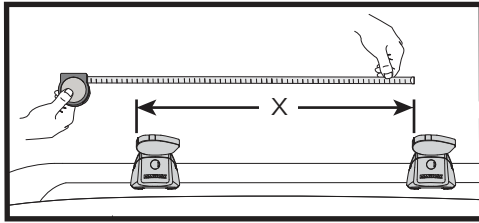

4X

5

**Carefully load the basket onto the vehicle.** With the assistance of a friend place the basket onto your crossbars. You may want to position the basket to one side so that you have room for other accessories on the other side.

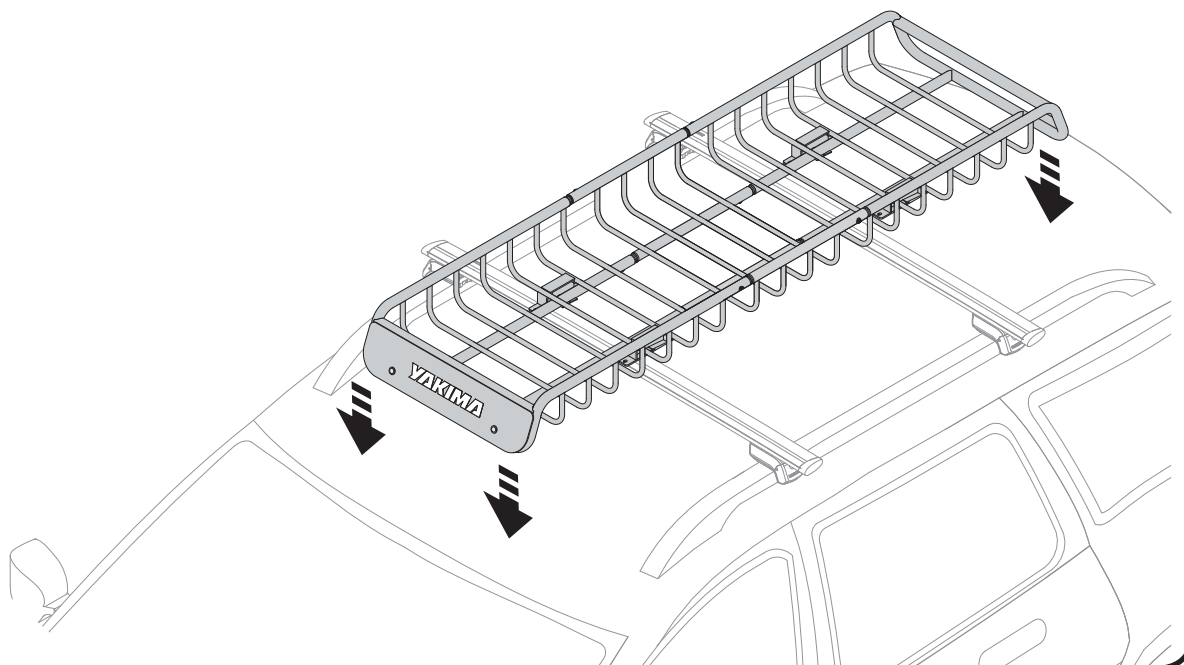

6

Position the support brackets above your vehicle's crossbars.

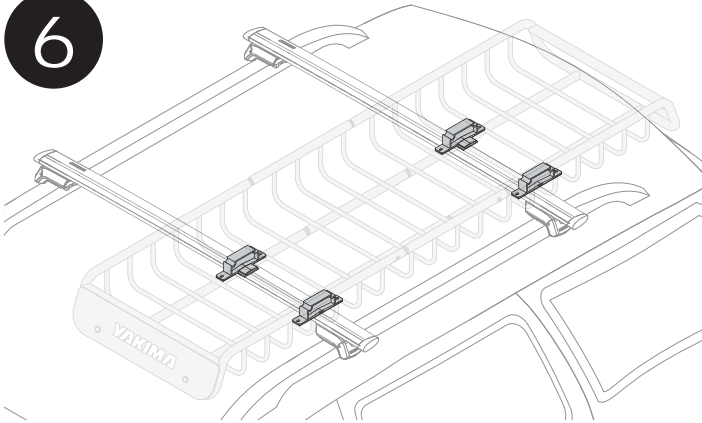

**Keep bar below tab!** It may be necessary to move the bracket to a new position, or to adjust the basket position.

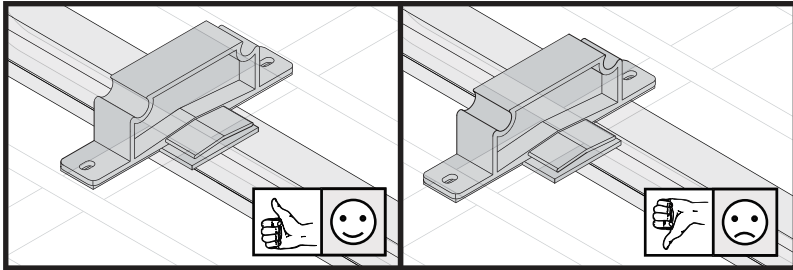

**DO NOT ATTACH THE BRACKETS TO THE EXTENSION.**

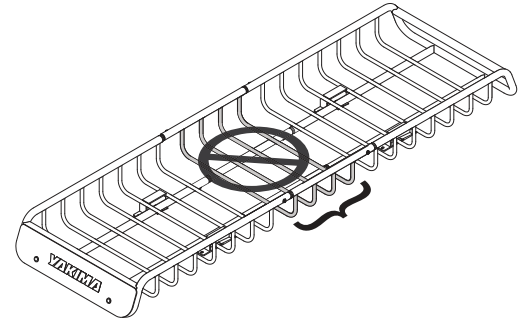

7

**Position the cover brackets.** Place cover brackets onto the installed support brackets. Hooked tab should cover the larger support bar.

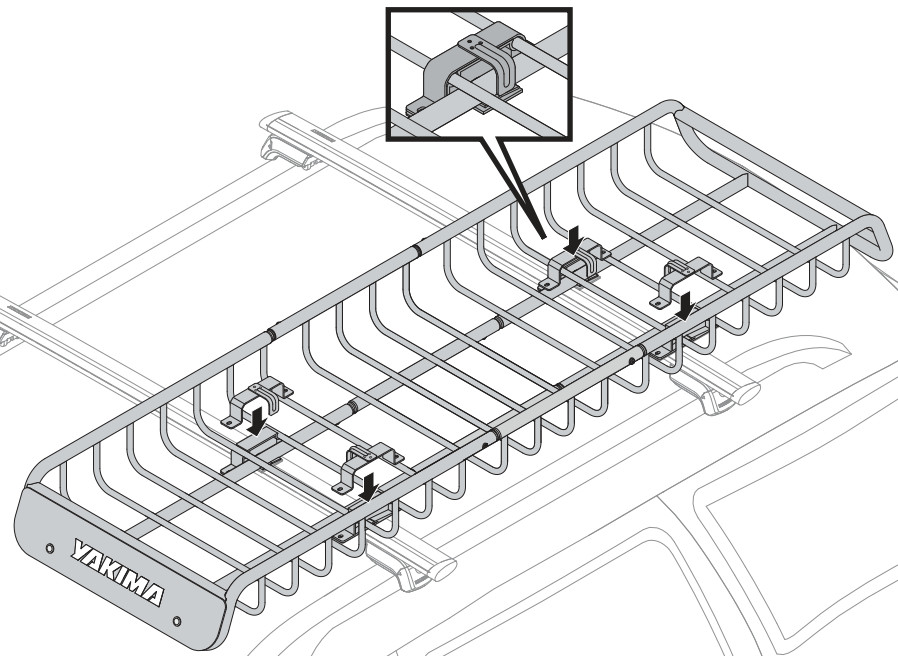

4X

8

**Attach the bottom bracket and knobs.** Insert and engage the threads of the t-bolt and carriage bolt.

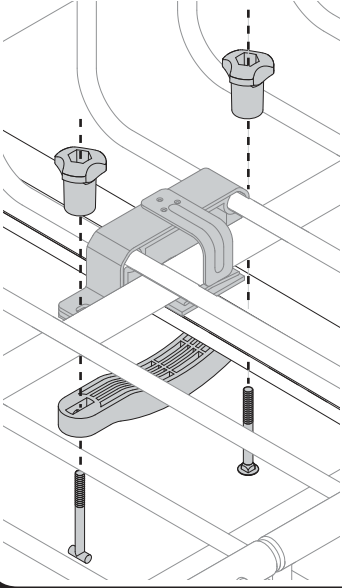

4X

9

**Tighten clamp to crossbar.** Completely tighten the t-bolt by rotating it 90° to rest in the slot, and turning the knob until tight. Then tighten the carriage bolt by turning the other knob until tight.

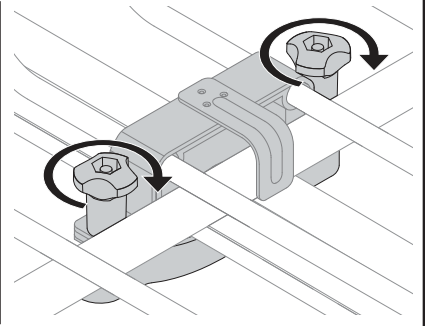
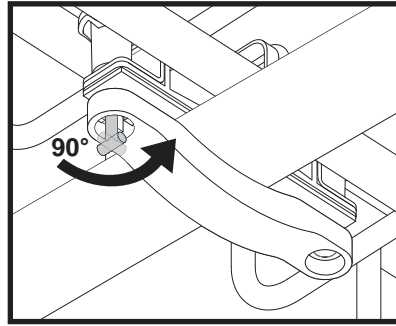

4X

10

**Test install.** The SkinnyWarrior should not slide or move on crossbars. Tighten knobs if necessary.

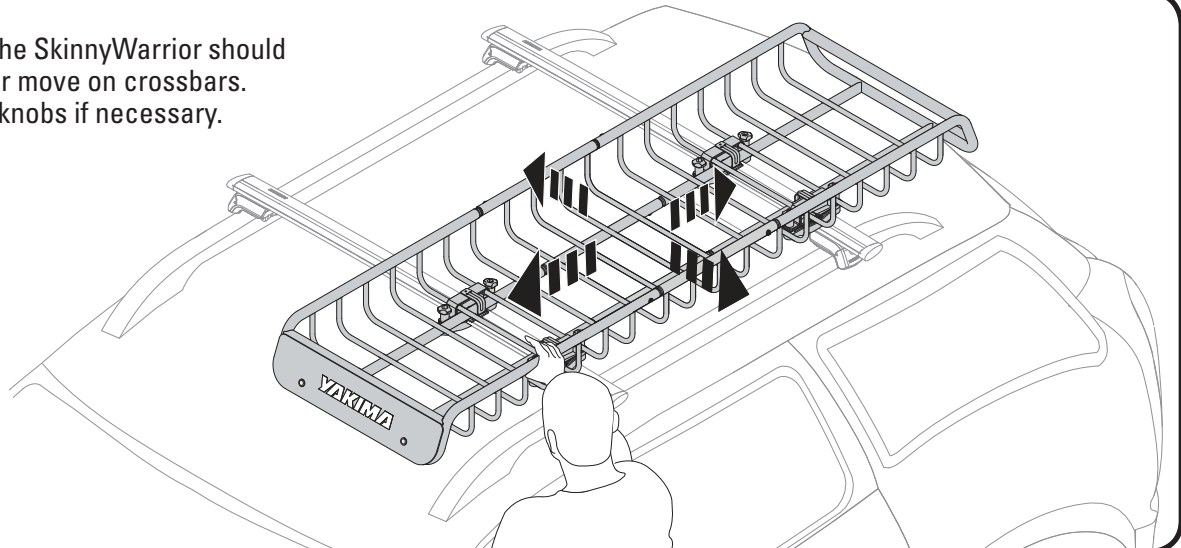

## LOADING

1

Always securely tie-down your load (tie-down straps not included).

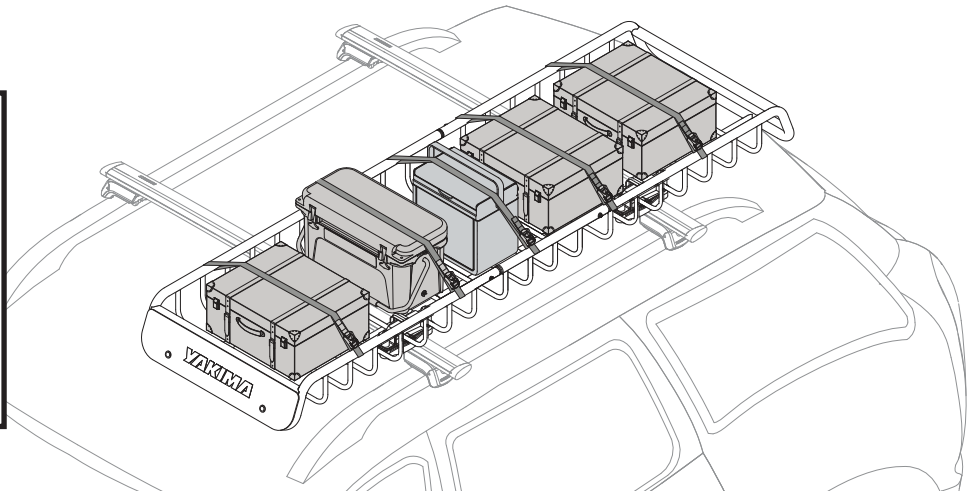

## REMOVAL

To remove the basket, do not disassemble the hardware.

- Loosen the knobs until barely attached.
- Twist the t-bolts and let the bottom brackets swing freely.
- Remove basket.

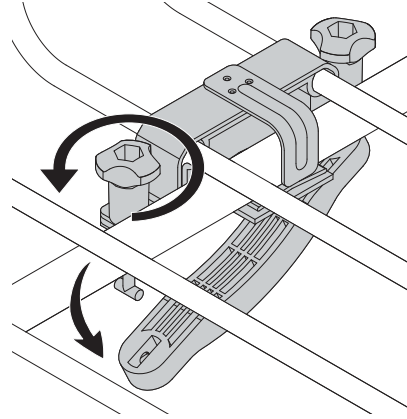

## MAINTENANCE

Use non-water soluble lubricant on screws. Use a soft cloth with water and mild detergent to clean plastic parts.

## WARNING



Be sure all hardware is secured according to instructions. Attachment hardware can loosen over time. Check before each use, and tighten if necessary.

## WEIGHT LIMITS

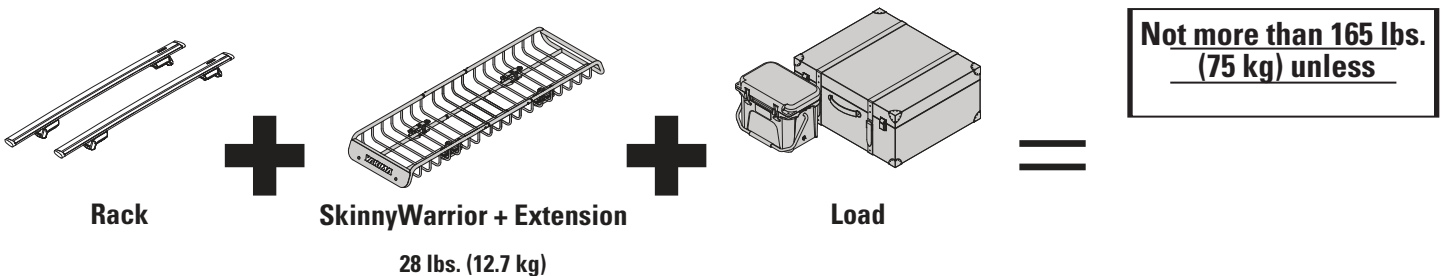

**KEEP THESE INSTRUCTIONS!**

## IMPORTANT WARNINGS

### Rack Installation

Inadequately secured loads and incorrectly mounted roof racks and accessory racks can come loose during travel and cause serious accidents! Therefore, installation, handling and use must be carried out in accordance with product and vehicle instructions.

In addition to these instructions, review the mounting instructions for the roof rack and the operating instructions of the vehicle.

These instructions should be kept together with the vehicle's operating instructions and carried in the vehicle when in use and en route.

For your own safety, you should only use roof racks that are authorized for use with your vehicle.

For roof racks that do not specify the distance between the front and rear crossbars, the distance shall be at least 762 mm or as large as possible. Please note that changes (e.g. additional drill holes) to the accessory rack's attachment system are not permissible.

Check attachment hardware and load for tight fit and function:

- Before the start of any journey.
- After driving a short distance following rack or load install.
- At regular intervals on longer journeys.
- More frequently on rough terrain.
- After interruption of a journey during which the vehicle was left unsupervised (check for damage due to outside intervention).

### Rack Loading

Do not exceed the maximum load specified for the roof rack, accessory rack or the maximum load recommended by the vehicle manufacturer.

**Max Roof Load = weight of roof rack + weight of accessory racks + weight of load.**

Load shall be uniformly distributed with the lowest possible center of gravity.

Load should not substantially extend beyond the loading surface of the roof rack.

### Boat Loading and Longer Loads

Use all provided straps to secure the boat in accordance with the instructions. Bow and stern tiedown lines must be used!

### Vehicle Driving and Regulations

The speed driven must be suited to the load transported and to official speed limits. In the absence of any speed limits, we recommend a maximum speed of 80 mph (130 km/h).

When transporting any load, the speed of the vehicle must take into account all conditions such as the state of the road, the surface of the road, traffic conditions, wind, etc. Vehicle handling, cornering, braking and sensitivity to side winds will change with the addition of roof top loads.

Off-road driving is not permitted and could result in damage to your vehicle or your gear.

### Maintenance

The accessory rack should be carefully cleaned and maintained, particularly during the winter months. Use only a solution of water and standard car wash liquid without any alcohol, bleach or ammonium additives.

For reasons of fuel economy and the safety of other road users, the accessory rack and roof rack should be removed when not in use.

Periodically inspect accessory rack for damage. Replace lost, damaged or worn parts. Use only original spare parts obtained from a stocking specialist, dealer or manufacturer.

Any changes made to the roof racks and accessory racks as well as the use of spare parts or accessories other than those supplied by the manufacturer will lead to the lapsing of the manufacturer's warranty and liability for any material damage or accidents. You should observe these instructions to the letter and only use the original parts supplied.

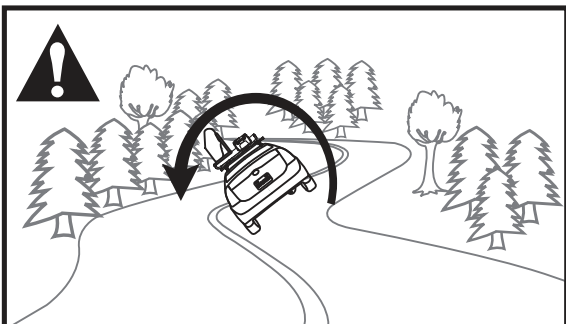
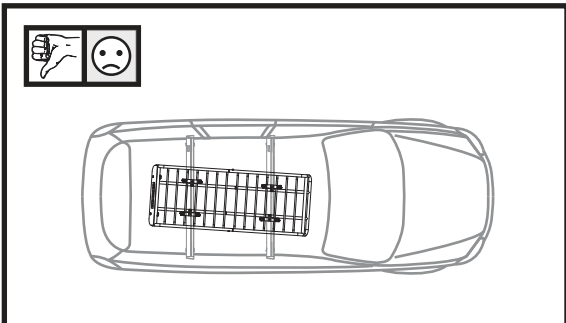
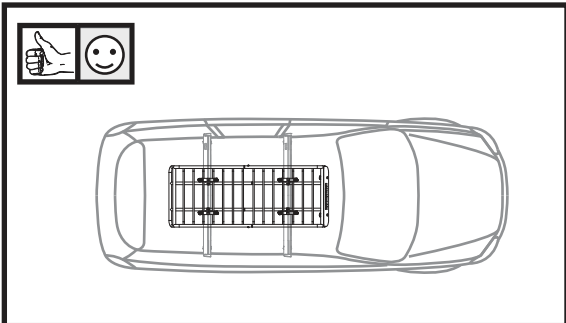
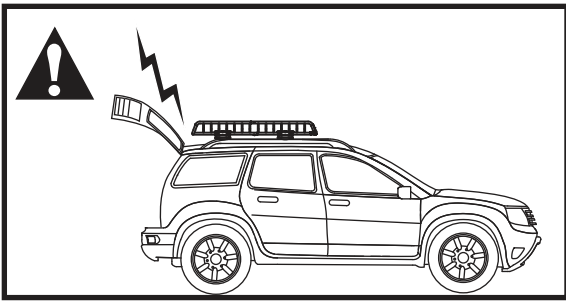

CAR WASH