

# YAKIMA

# 12 x 100 Fork Adapter **US**

**USE ON FORKS WITH 100mm HUB SPACING ONLY.**

- 1 REMOVE FRONT WHEEL:**  
Completely unthread and pull out the thru-axle skewer.



*Different manufacturers have different methods of wheel removal, follow your fork manufacturer's directions.*

- 2 INSTALL FORK ADAPTER:**  
*Attach the FORK ADAPTER while bike is still on the ground.*

- Slide the FORK ADAPTER between fork drop outs. Slide axle back through fork dropouts, and through the FORK ADAPTER.
- Completely tighten and close the thru-axle lever as you would if you were installing your front wheel.



*FORK ADAPTER legs must run parallel with the fork leg, unless you are running several bikes on your rack. Conflicting handlebar heights require the FORK ADAPTER to be rotated (maximum of 180°).*

*This figure may differ from your fork. Follow your fork manufacturer's directions for wheel removal, axle and axle bolt location and tightening.*

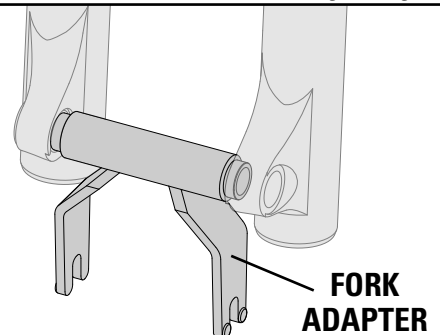

- 3 ATTACH TO FORK-MOUNTED BIKE RACK**
- Check the thru-axle is tight and the FORK Adapter is securely attached to your fork.
  - Attach the FORK ADAPTER onto your fork-mounted rack. (Follow the manufacturer's directions on tightening down the quick release before driving away.)



*Be sure FORK ADAPTER and bike are both mounted securely to your bike rack before driving.*

- 4 TO REMOVE FORK ADAPTER**  
*(Do not leave FORK ADAPTER attached to your rack.)*

- Remove the bike from your rack with the FORK ADAPTER still attached to your fork.
- Set the bike on the ground, open and unthread the thru-axle.
- Slide out the axle from the FORK ADAPTER and remove the FORK ADAPTER.
- Insert your front wheel; securely tighten the thru-axle before riding.

- 5 BEFORE RIDING:**

- Check that your thru-axle is tight and your front brake works properly.

### MAINTENANCE

Periodically check for excessive wear, including rust or cracks. Replace if cracked or rusted.

**REMOVE ACCESSORY BEFORE ENTERING AN AUTOMATIC CAR WASH.**

### WARNING:

**BE SURE ALL HARDWARE IS SECURED ACCORDING TO INSTRUCTIONS. ATTACHMENT HARDWARE CAN LOOSEN OVER TIME. CHECK BEFORE EACH USE, AND TIGHTEN IF NECESSARY.**



## KEEP THESE INSTRUCTIONS!

**IMPORTANT WARNING:** IT IS CRITICAL THAT ALL YAKIMA RACKS AND ACCESSORIES BE PROPERLY AND SECURELY ATTACHED TO YOUR VEHICLE. IMPROPER ATTACHMENT COULD RESULT IN AN AUTOMOBILE ACCIDENT, AND COULD CAUSE SERIOUS BODILY INJURY OR DEATH TO YOU OR TO OTHERS. YOU ARE RESPONSIBLE FOR SECURING THE RACKS AND ACCESSORIES TO YOUR CAR, CHECKING THE ATTACHMENTS PRIOR TO USE, AND PERIODICALLY INSPECTING THE PRODUCTS FOR ADJUSTMENT, WEAR, AND DAMAGE. THEREFORE, YOU MUST READ AND UNDERSTAND ALL OF THE INSTRUCTIONS AND CAUTIONS SUPPLIED WITH YOUR YAKIMA PRODUCT PRIOR TO INSTALLATION OR USE. IF YOU DO NOT UNDERSTAND ALL OF THE INSTRUCTIONS AND CAUTIONS, OR IF YOU HAVE NO MECHANICAL EXPERIENCE AND ARE NOT THOROUGHLY FAMILIAR WITH THE INSTALLATION PROCEDURES, YOU SHOULD HAVE THE PRODUCT INSTALLED BY A PROFESSIONAL INSTALLER SUCH AS A QUALIFIED GARAGE OR AUTO BODY SHOP.

Choose premium roof racks now and transport your cargo safely and easily.