

# YAKIMA

# Rotopax Mounting Kit

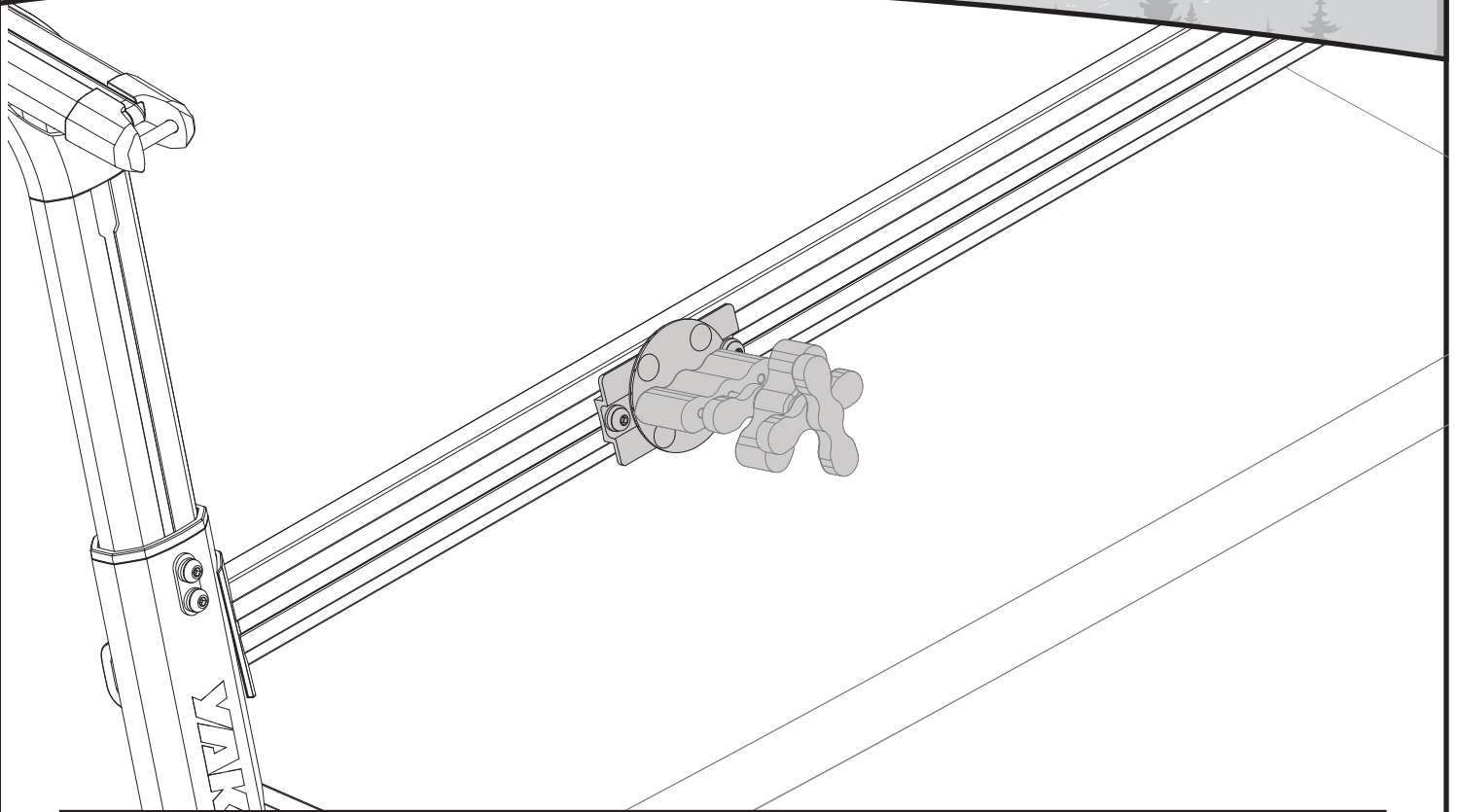

## Contents

Base Plate (1X)

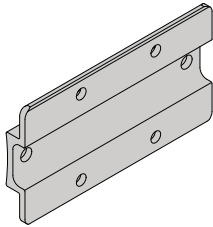

M8 flat washer (2X)



Mount Spacer (1X)

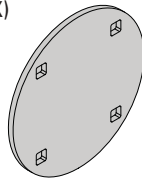

M8 lock washer (2X)



Long nut plate (1X)

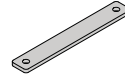

M8x18mm screw (2X)



5mm Hex Wrench (1X)

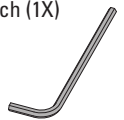

## Capacity

Gear capacity - 1, 1.75, 2, 3,  
or 4 gallon Rotopax packs.

Load Capacity:

40 lbs (18 Kg) on-road

25 lbs (11.3 Kg) off-road

## Compatibility

Compatibility: Most t-slot  
crossbars, platforms, or side bars.

1

**Attach the Rotopax Mount.** Assemble the Rotopax Mount Adapter with your Rotopax RX series Mount (sold separately) using the hardware that came with your Rotopax RX series Mount as shown, and tighten to 4 Nm with a 7/16" wrench.

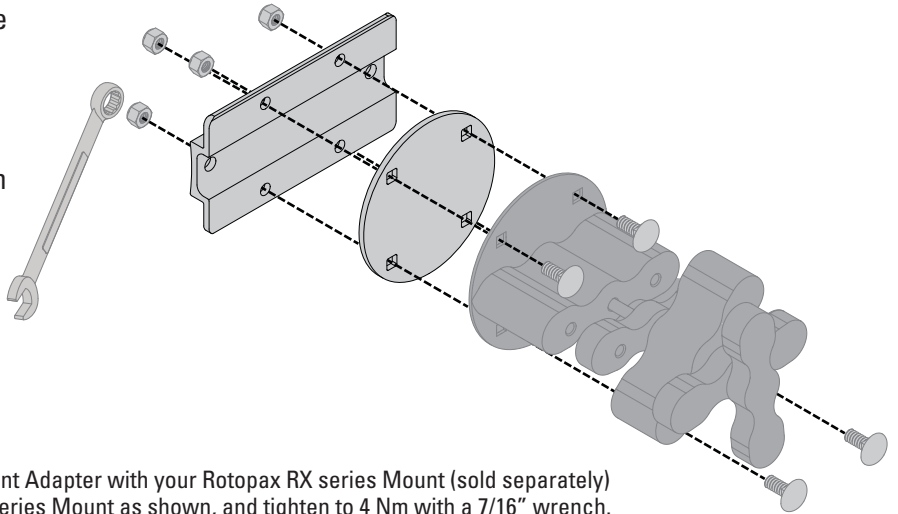

**Attach the Rotopax Mount.** Assemble the Rotopax Mount Adapter with your Rotopax RX series Mount (sold separately) using the hardware that came with your Rotopack RX series Mount as shown, and tighten to 4 Nm with a 7/16" wrench.

## INSTALLATION

1

**Slide the nut plate into the t-slot.**  
Note: This may require SideBar be off the truck depending on the spread between front and rear towers.

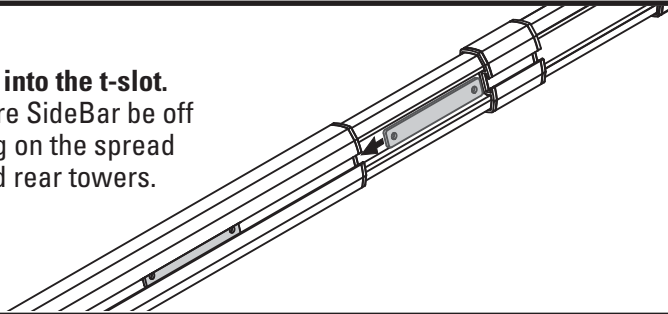

2

**Attach the Rotopax Mount assembly.** Loosely attach the base to the nut plate as shown

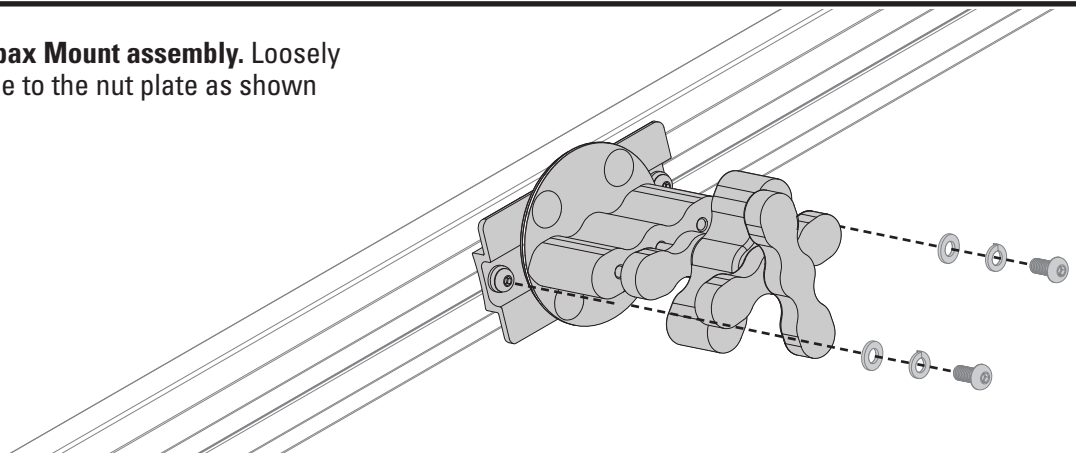

3

**Position and tighten the mount.**  
Position the mount, and tighten to 4 Nm using the hex wrench.

4 Nm

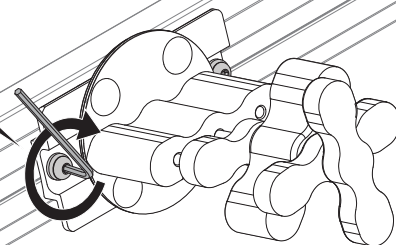

2X

## LOADING

1

**Load the Rotopax.** Load the Rotopax container and tighten the handle as instructed by Rotopax.

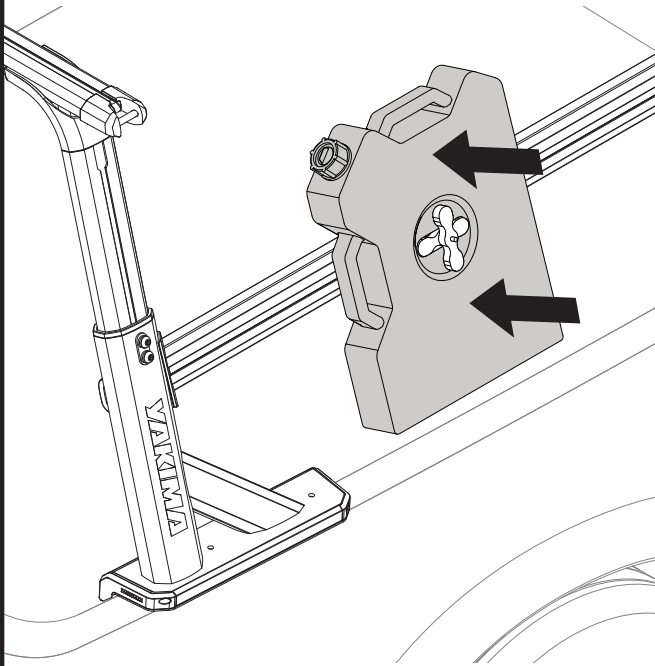

2

**Verify installation.** Check that everything is secure by tugging at the Rotopax in all direction. Retighten if anything is not securely attached.

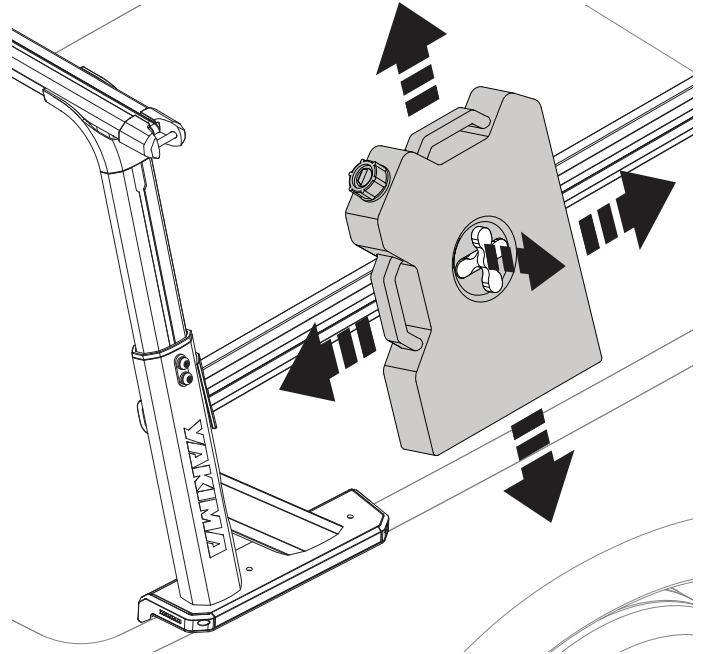

## REMOVAL

1. Loosen and remove M8 hardware.
2. Remove the base.
3. Remove the long nut plate.

## IMPORTANT WARNINGS

### Rack Installation

Inadequately secured loads and incorrectly mounted roof racks and accessory racks can come loose during travel and cause serious accidents! Therefore, installation, handling and use must be carried out in accordance with product and vehicle instructions.

In addition to these instructions, review the mounting instructions for the roof rack and the operating instructions of the vehicle.

These instructions should be kept together with the vehicle's operating instructions and carried in the vehicle when in use and en route.

For your own safety, you should only use roof racks that are authorized for use with your vehicle.

For roof racks that do not specify the distance between the front and rear crossbars, the distance shall be at least 700 mm or as large as possible. Please note that changes (e.g. additional drill holes) to the accessory rack's attachment system are not permissible.

Check attachment hardware and load for tight fit and function:

- Before the start of any journey.
- After driving a short distance following rack or load install.
- At regular intervals on longer journeys.
- More frequently on rough terrain.
- After interruption of a journey during which the vehicle was left unsupervised (check for damage due to outside intervention).

### Rack Loading

Do not exceed the maximum load specified for the roof rack, accessory rack or the maximum load recommended by the vehicle manufacturer.

**Max Roof Load = weight of roof rack + weight of accessory racks + weight of load.**

Load shall be uniformly distributed with the lowest possible center of gravity.

Load should not substantially extend beyond the loading surface of the roof rack.

### Vehicle Driving and Regulations

The speed driven must be suited to the load transported and to official speed limits. In the absence of any speed limits, we recommend a maximum speed of 80 mph (130 km/h).

When transporting any load, the speed of the vehicle must take into account all conditions such as the state of the road, the surface of the road, traffic conditions, wind, etc. Vehicle handling, cornering, braking and sensitivity to side winds will change with the addition of roof top loads.

If this product is off-road certified, it is designed and intended to be used on forest service roads, access roads or other non-technical terrains at moderate speeds. It is not to be used while rock-crawling, jumping, bogging, or other technical off-road terrains. When using off-road certified products with non-off-road certified products, always follow the warnings and restrictions stated in the non-off-road certified product instructions.

### Maintenance

The accessory rack should be carefully cleaned and maintained, particularly during the winter months. Use only a solution of water and standard car wash liquid without any alcohol, bleach or ammonium additives.

For reasons of fuel economy and the safety of other road users, the accessory rack and roof rack should be removed when not in use.

Periodically inspect accessory rack for damage. Replace lost, damaged or worn parts. Use only original spare parts obtained from a stocking specialist, dealer or manufacturer.

Any changes made to the roof racks and accessory racks as well as the use of spare parts or accessories other than those supplied by the manufacturer will lead to the lapsing of the manufacturer's warranty and liability for any material damage or accidents. You should observe these instructions to the letter and only use the original parts supplied.