

# YAKIMA

# Tonneau Kit 1

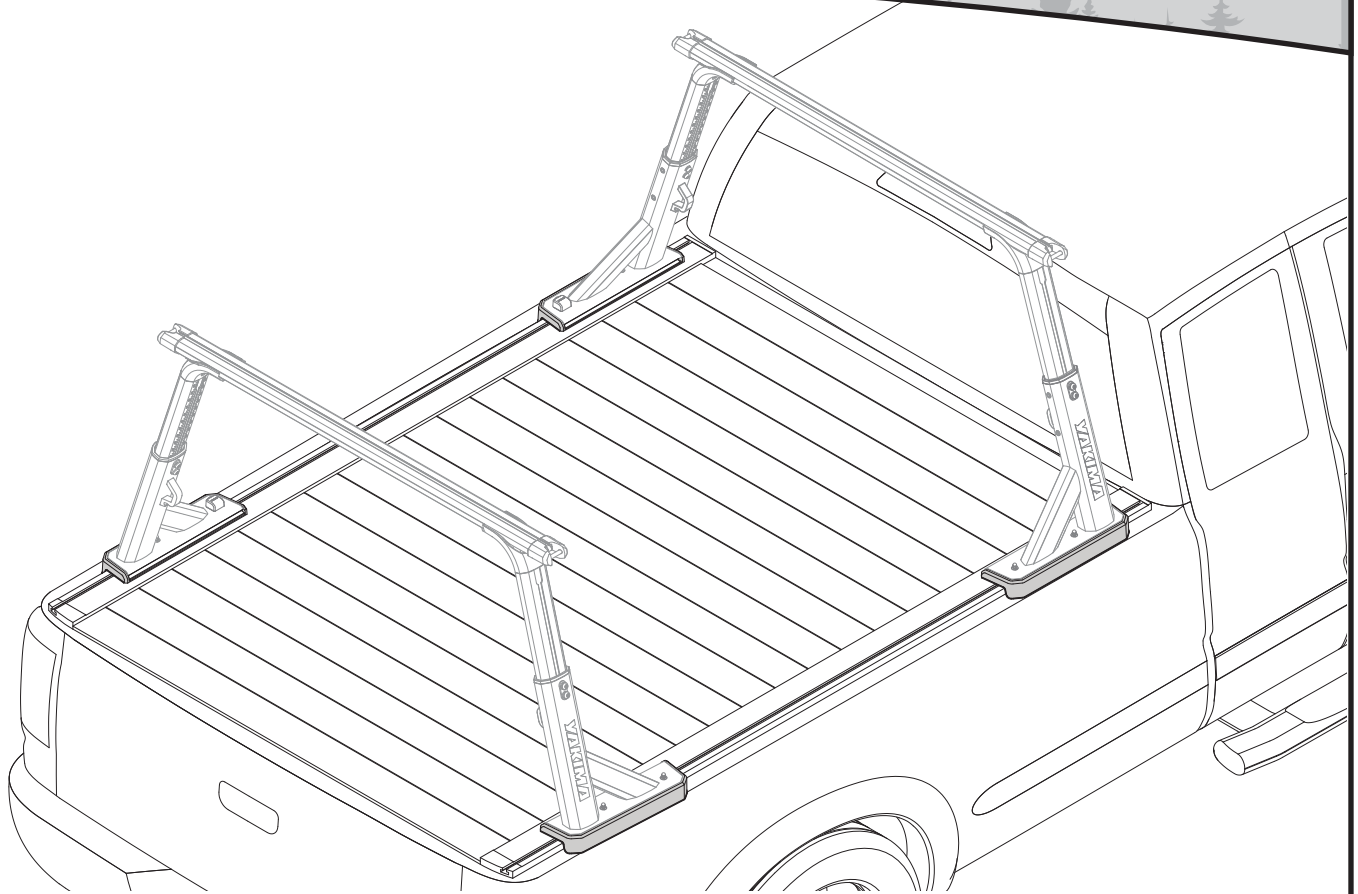

### Contents

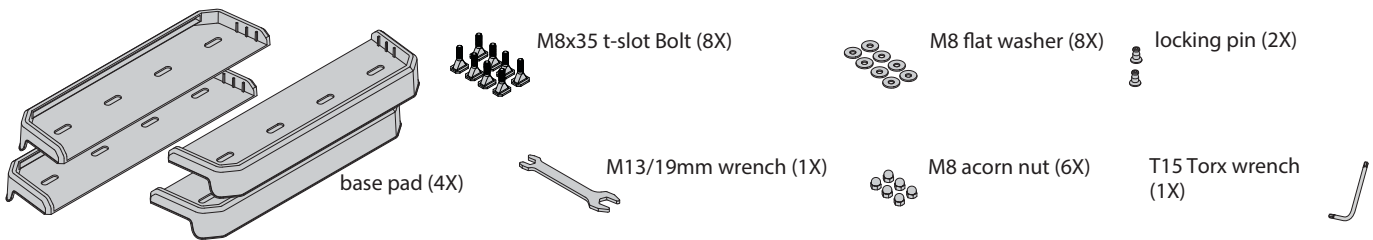

### Capacity

300 lb (136 Kg) on-road  
180 (82 Kg) off-road  
800 lb (363 Kg) Static Load Limit

### Compatibility

Tonneau Kit 1 for Retrax XR  
series tonneau covers

### Available accessories

SideBar Short Bed  
#8001153



SideBar Long Bed  
#8001154



HD Hook Straps  
#8001165



Ladder Roller  
#8001163



Load Stop  
#8001161



Eye Bolts  
#8001162



Rotopax Mounting Kit\*  
#8001167



\*Rotopax mount sold separately

1

**Insert t-bolts.** Clean your tonneau rail's t-slots, then insert 4 t-bolts into the track on each side of your tonneau cover.

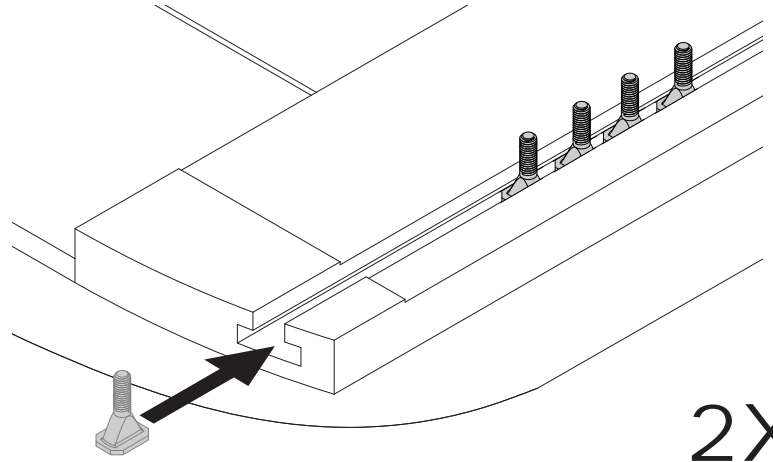

2X

**Position t-bolts.** Move the t-bolts to the approximate position that you'll install your OverHaul HD or OutPost HD towers.

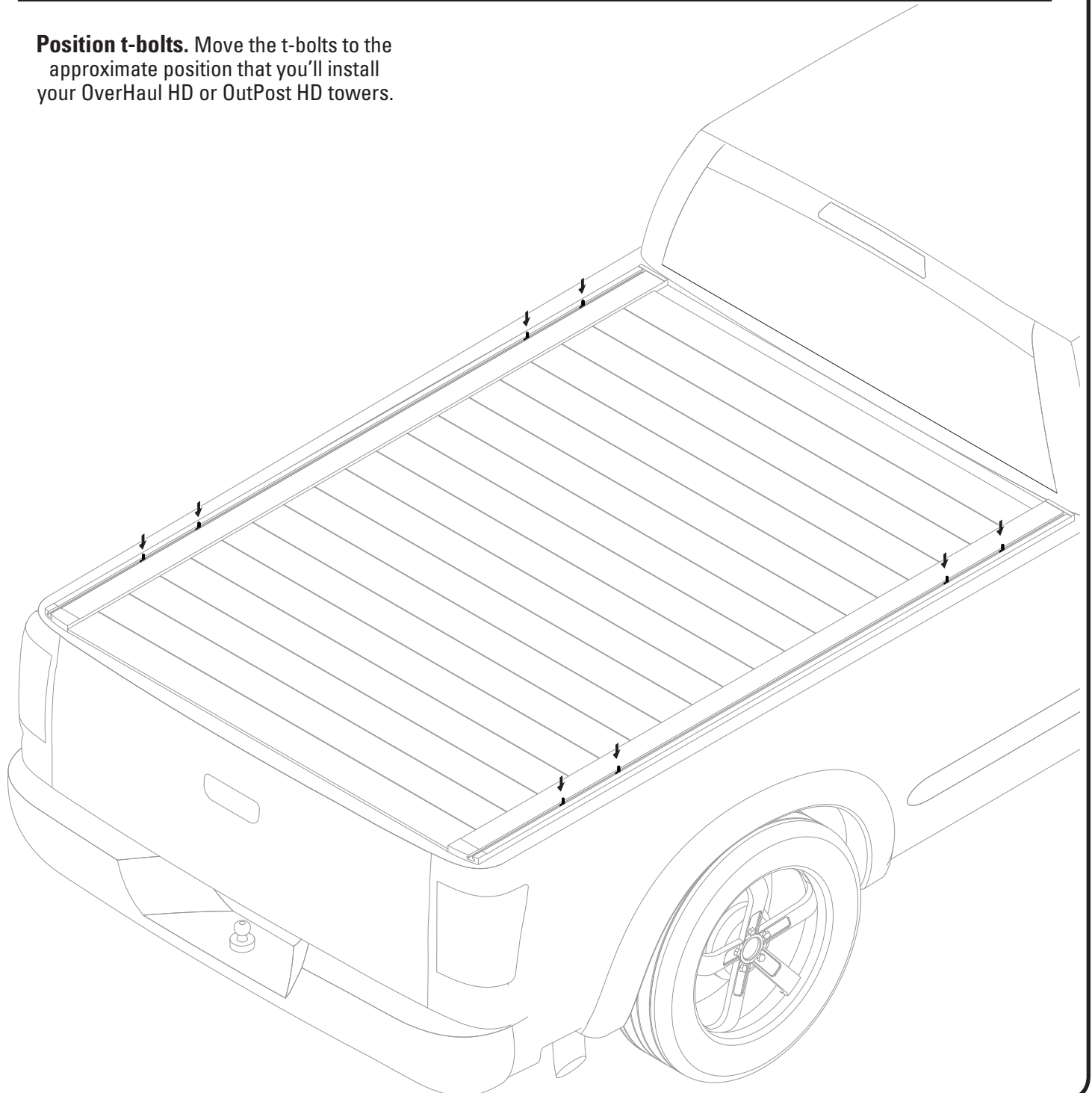

2

**Place base pads and towers.** Place the base pads over t-bolts. Then place towers over base pads and t-bolts. **NOTE:** Make sure the long side of the OverHaul HD or OutPost HD towers face each other as shown.

Then loosely install the hardware.

**IMPORTANT:** On the driver side install a locking pin on both the front and rear tower.

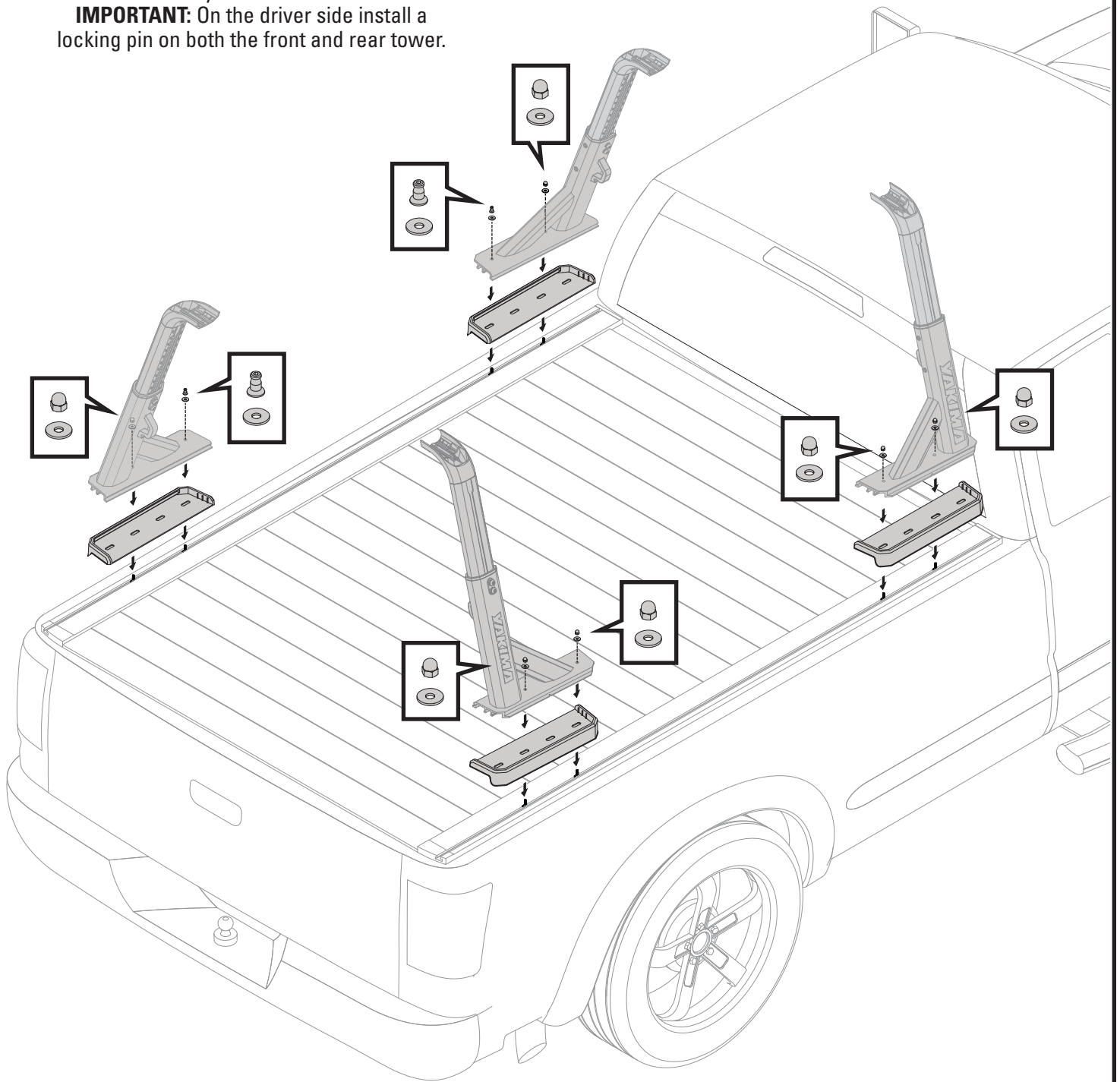

**3**

**Position the bases.** Equally measure from the cab to the base of the towers to position your front rack. Then equally measure from the front towers to position the rear towers (**minimum crossbar spread is 36" (91.4 cm)**).

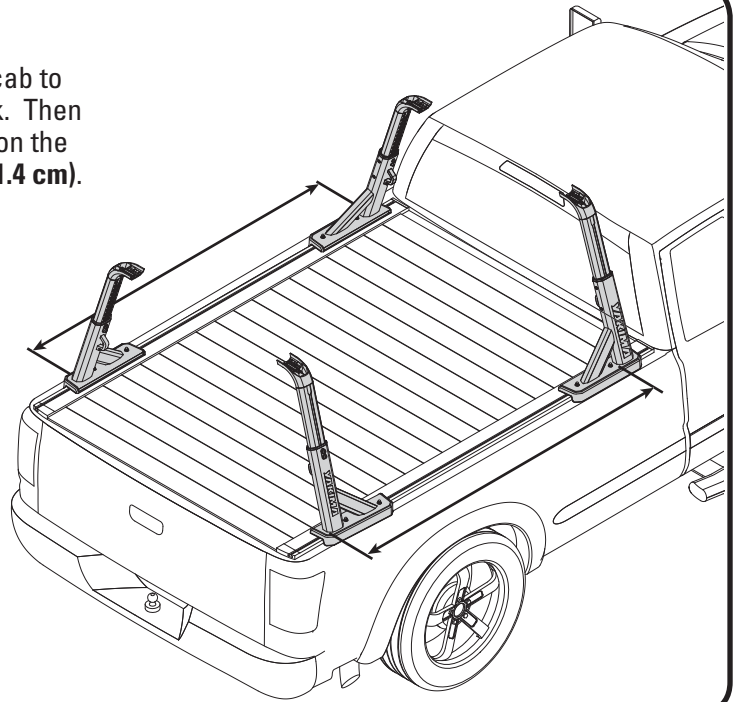
**4**

**Tighten the nuts.** Using the 13 mm wrench tighten the acorn nuts to 10 Nm.

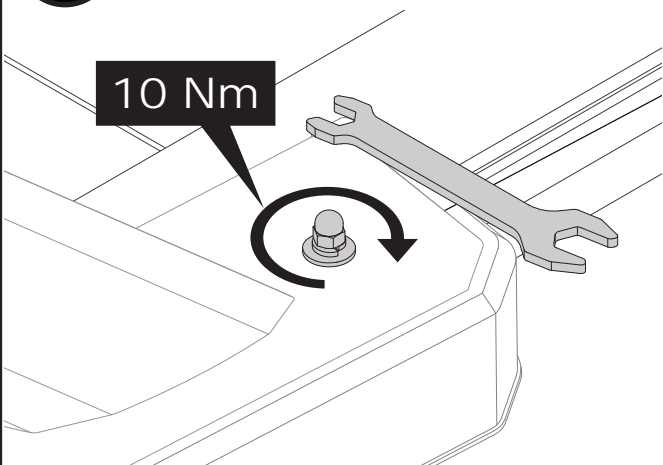
**6X****5**

**Tighten the lock posts.** Using the 4 mm hex wrench included with your OutPost HD or OverHaul HD tighten the lock posts to 10 Nm.

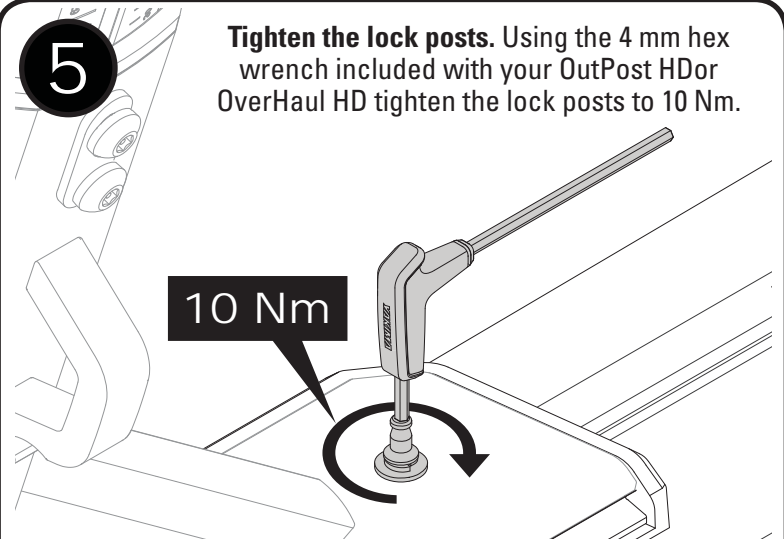
**2X****6**

To lock your system, first remove the screw from each lock housing with the T-15 wrench.

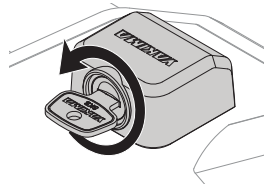
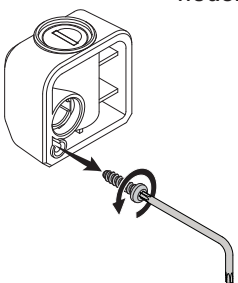
**2X****7**

You may now proceed with OverHaul HD or OutPost HD crossbar attachment by following the pertinent steps in their respective instructions.

## IMPORTANT WARNINGS

### Rack Installation

Inadequately secured loads and incorrectly mounted roof racks and accessory racks can come loose during travel and cause serious accidents! Therefore, installation, handling and use must be carried out in accordance with product and vehicle instructions.

In addition to these instructions, review the mounting instructions for the roof rack and the operating instructions of the vehicle.

These instructions should be kept together with the vehicle's operating instructions and carried in the vehicle when in use and en route.

For your own safety, you should only use roof racks that are authorized for use with your vehicle.

For roof racks that do not specify the distance between the front and rear crossbars, the distance shall be at least 700 mm or as large as possible. Please note that changes (e.g. additional drill holes) to the accessory rack's attachment system are not permissible.

Check attachment hardware and load for tight fit and function:

- Before the start of any journey.
- After driving a short distance following rack or load install.
- At regular intervals on longer journeys.
- More frequently on rough terrain.
- After interruption of a journey during which the vehicle was left unsupervised (check for damage due to outside intervention).

### Rack Loading

Do not exceed the maximum load specified for the roof rack, accessory rack or the maximum load recommended by the vehicle manufacturer.

**Max Roof Load = weight of roof rack + weight of accessory racks + weight of load.**

Load shall be uniformly distributed with the lowest possible center of gravity.

Load should not substantially extend beyond the loading surface of the roof rack.

### Vehicle Driving and Regulations

The speed driven must be suited to the load transported and to official speed limits. In the absence of any speed limits, we recommend a maximum speed of 80 mph (130 km/h).

When transporting any load, the speed of the vehicle must take into account all conditions such as the state of the road, the surface of the road, traffic conditions, wind, etc. Vehicle handling, cornering, braking and sensitivity to side winds will change with the addition of roof top loads.

If this product is off-road certified, it is designed and intended to be used on forest service roads, access roads or other non-technical terrains at moderate speeds. It is not to be used while rock-crawling, jumping, bogging, or other technical off-road terrains. When using off-road certified products with non-off-road certified products, always follow the warnings and restrictions stated in the non-off-road certified product instructions.

### Maintenance

The accessory rack should be carefully cleaned and maintained, particularly during the winter months. Use only a solution of water and standard car wash liquid without any alcohol, bleach or ammonium additives.

For reasons of fuel economy and the safety of other road users, the accessory rack and roof rack should be removed when not in use.

Periodically inspect accessory rack for damage. Replace lost, damaged or worn parts. Use only original spare parts obtained from a stocking specialist, dealer or manufacturer.

Any changes made to the roof racks and accessory racks as well as the use of spare parts or accessories other than those supplied by the manufacturer will lead to the lapsing of the manufacturer's warranty and liability for any material damage or accidents. You should observe these instructions to the letter and only use the original parts supplied.