

YAKIMA

SideBar

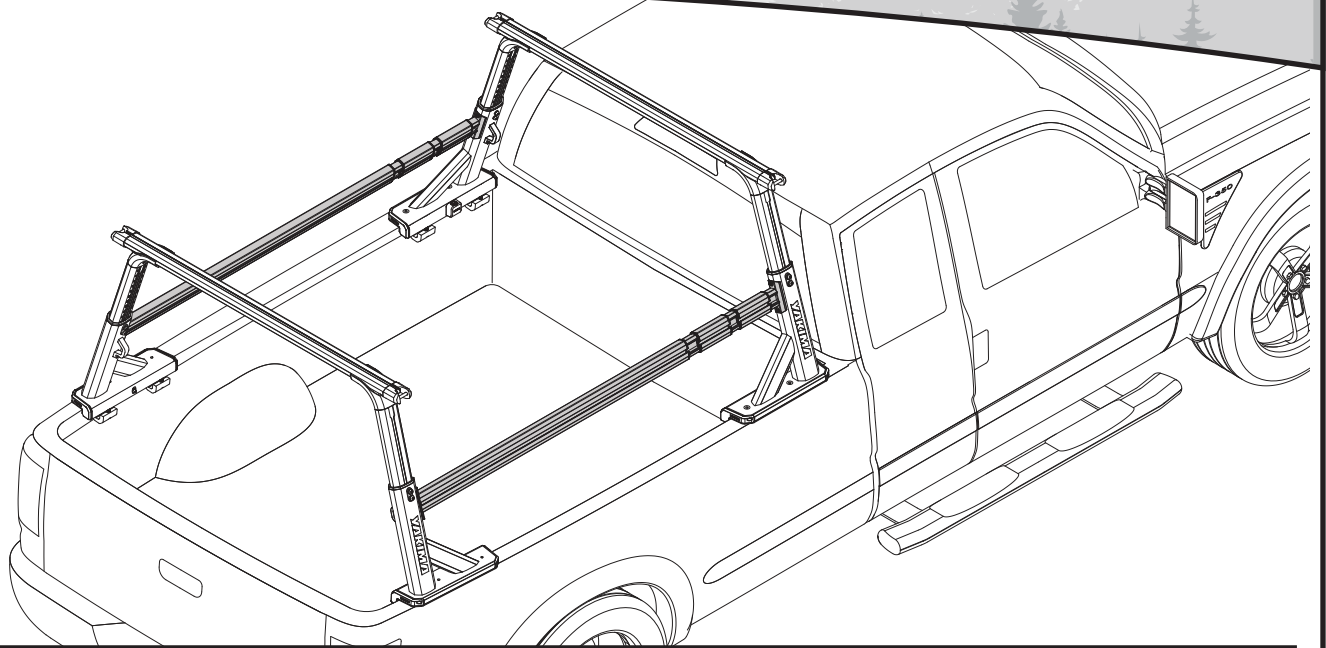

Contents

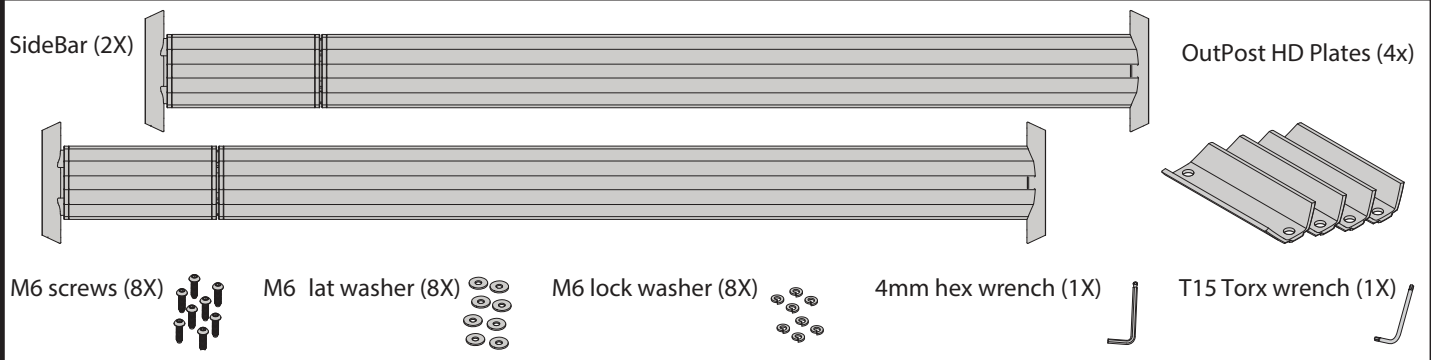

Load capacity

100 lbs (45.4kg) (evenly distributed)
T-slot is for use with Yakima
accessories only.

Crossbar spread

SideBar, Short Bed - Adjustable from 36-64" (91.5-162.5 cm)*
SideBar, Long Bed - Adjustable from 60-84" (152.4-213.4 cm) *
*minimum requires removal of t-slot sleeves

Available accessories



Recovery Track Mount
#8001164



HD Hook Straps
#8001165



Eye Bolts
#8001162



Rotopax Mounting Kit*
#8001167

*Rotopax mount sold separately

1

Loosen the length adjustment screw.

NOTE: If installing a Rotopax Mounting Kit, slide the long nut plate into the t-slot before you install the SideBar.

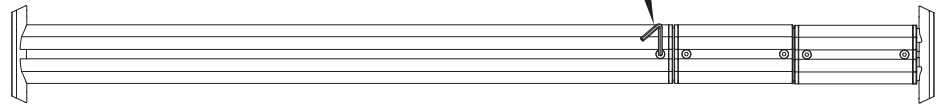
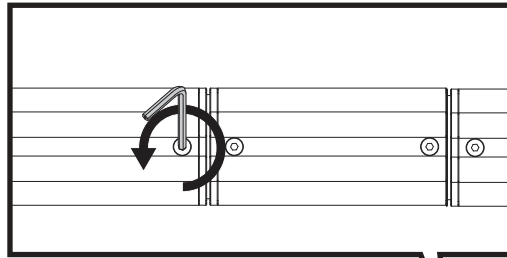

2X

Optional: To achieve the minimum SideBar length you must remove the t-slot sleeve. See page 4 for instruction on how to remove the sleeve.

2

Install the SideBars.

- Get a friend to help.
- Clean the towers before attaching SideBars to them.
- SideBars can be mounted in either direction.
- First align the holes while extending the SideBar to meet the towers.
- **Note:** If installing on Yakima OutPost HD use the OutPost HD plates.
- Loosely install the hardware.
- Then use the 4mm wrench to fully tighten the SideBars to 4 Nm.

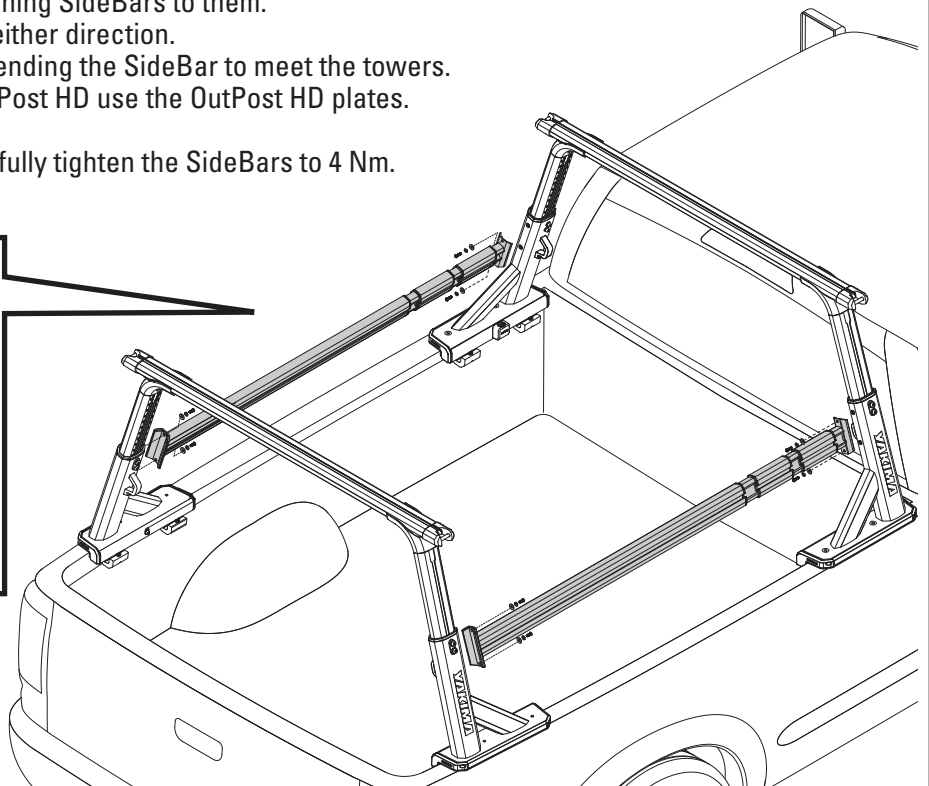
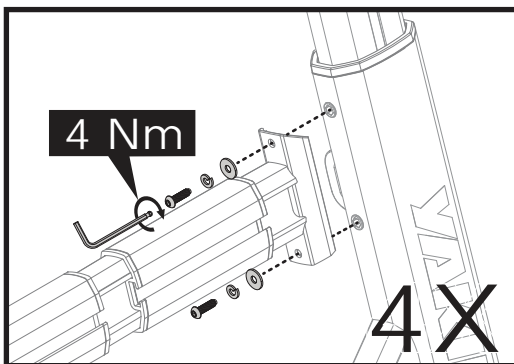

3

Tighten the length adjustment screw to 4 Nm.

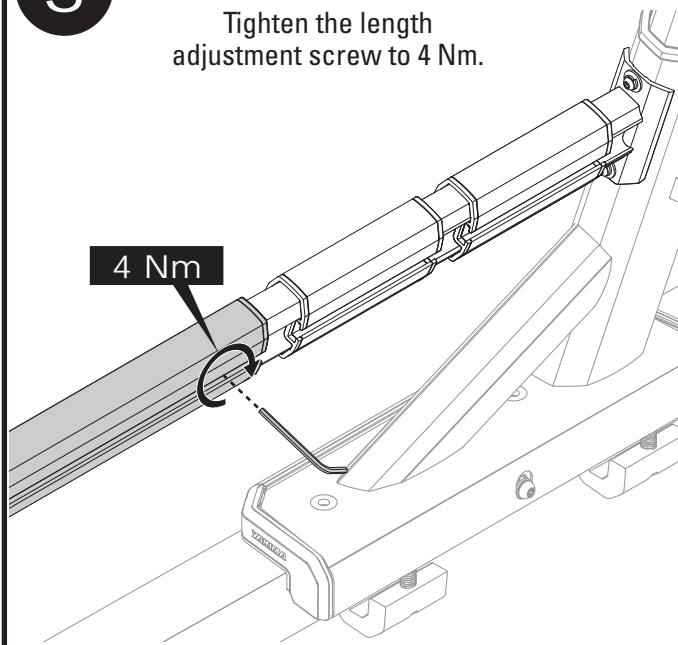

2X

4

Loosen and position SideBar T-Slot sleeves where HD accessories will be located, then tighten to 4 Nm before installing any accessories.

Note: SideBar - Short Bed has one per side, SideBar - Long Bed has two per side.

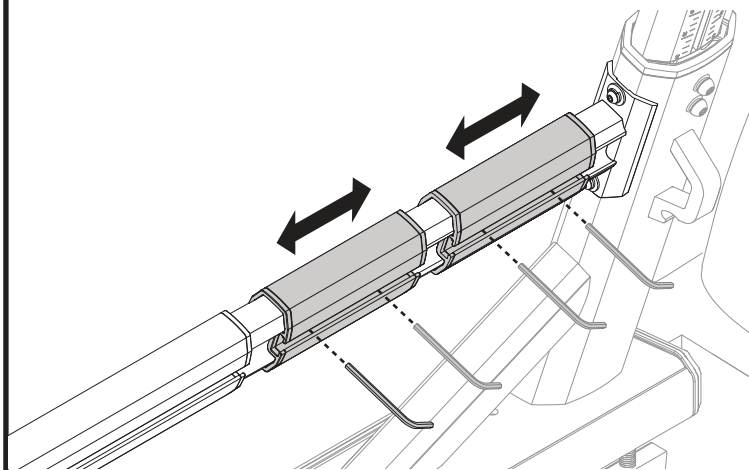

LOADING

Follow your HD accessory instructions for loading instruction.

REMOVAL

1. Loosen adjustment screw and M6 hardware.
2. Remove M6 hardware (and OutPost HD plates if used).
3. Remove SideBar.

YAKIMA

OPTIONAL

To achieve the minimum SideBar length you must remove the t-slot sleeves.

- A. Remove the length adjustment screw (retain to reinstall in step F) with the 4 mm wrench.
- B. Slide the extension out completely.
- C. Using the T15 wrench, remove the screw and end cap from the extension.
- D. Loosen the screws and slide the collar (retain the square nut to reinstall in step E) and t-slot sleeves off.
- E. Reinstall the collar and square nut, with the flange facing the end bracket as shown. Reinstall the end cap and tighten to 4 Nm.
- F. Reinsert the extension, loosely reinstall the adjustment screw, and proceed with installation step 2.

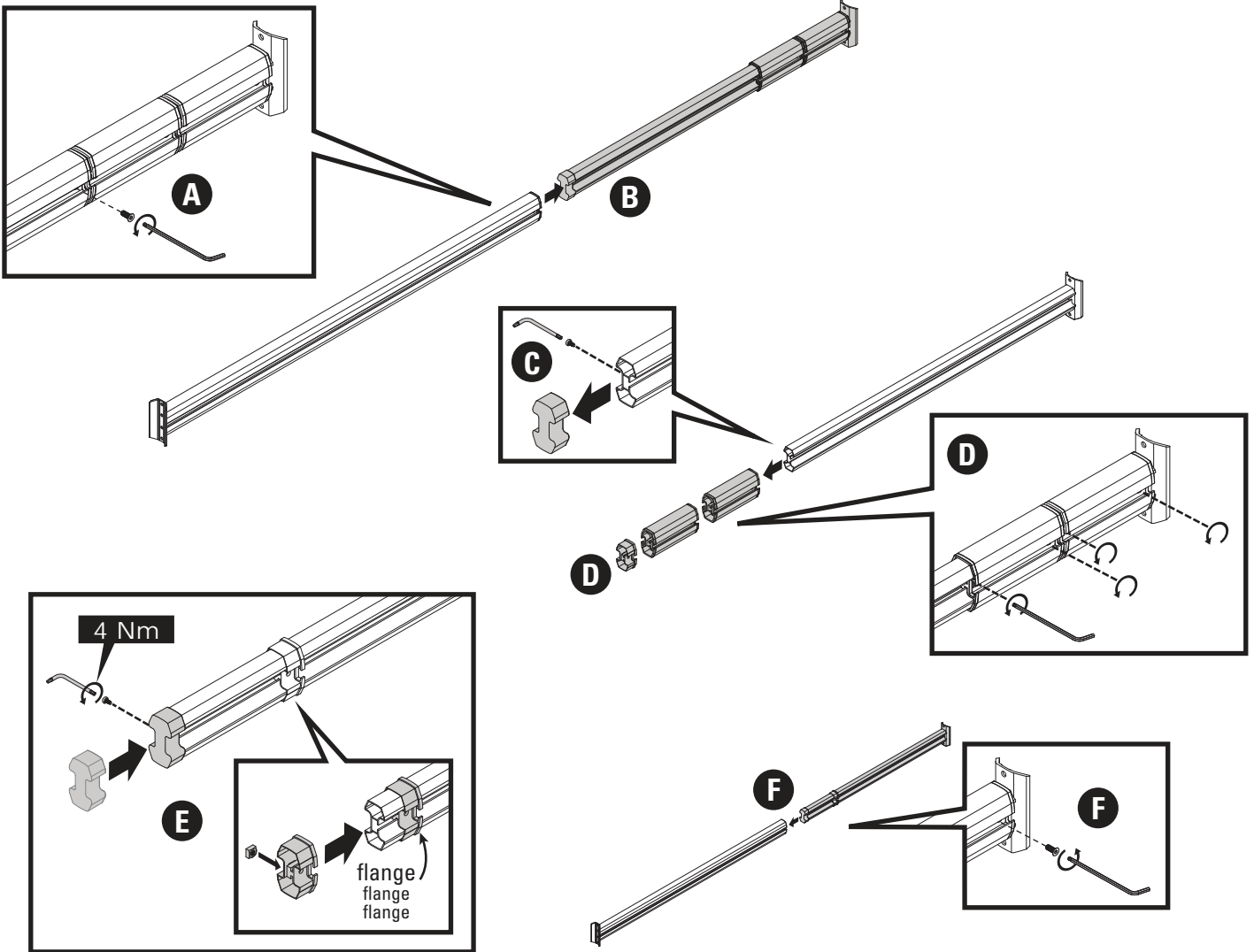

IMPORTANT WARNINGS

Rack Installation

Inadequately secured loads and incorrectly mounted roof racks and accessory racks can come loose during travel and cause serious accidents! Therefore, installation, handling and use must be carried out in accordance with product and vehicle instructions.

In addition to these instructions, review the mounting instructions for the roof rack and the operating instructions of the vehicle.

These instructions should be kept together with the vehicle's operating instructions and carried in the vehicle when in use and en route.

For your own safety, you should only use roof racks that are authorized for use with your vehicle.

For roof racks that do not specify the distance between the front and rear crossbars, the distance shall be at least 700 mm or as large as possible. Please note that changes (e.g. additional drill holes) to the accessory rack's attachment system are not permissible.

Check attachment hardware and load for tight fit and function:

- Before the start of any journey.
- After driving a short distance following rack or load install.
- At regular intervals on longer journeys.
- More frequently on rough terrain.
- After interruption of a journey during which the vehicle was left unsupervised (check for damage due to outside intervention).

Rack Loading

Do not exceed the maximum load specified for the roof rack, accessory rack or the maximum load recommended by the vehicle manufacturer.

Max Roof Load = weight of roof rack + weight of accessory racks + weight of load.

Load shall be uniformly distributed with the lowest possible center of gravity.

Load should not substantially extend beyond the loading surface of the roof rack.

Vehicle Driving and Regulations

The speed driven must be suited to the load transported and to official speed limits. In the absence of any speed limits, we recommend a maximum speed of 80 mph (130 km/h).

When transporting any load, the speed of the vehicle must take into account all conditions such as the state of the road, the surface of the road, traffic conditions, wind, etc. Vehicle handling, cornering, braking and sensitivity to side winds will change with the addition of roof top loads.

If this product is off-road certified, it is designed and intended to be used on forest service roads, access roads or other non-technical terrains at moderate speeds. It is not to be used while rock-crawling, jumping, bogging, or other technical off-road terrains. When using off-road certified products with non-off-road certified products, always follow the warnings and restrictions stated in the non-off-road certified product instructions.

Maintenance

The accessory rack should be carefully cleaned and maintained, particularly during the winter months. Use only a solution of water and standard car wash liquid without any alcohol, bleach or ammonium additives.

For reasons of fuel economy and the safety of other road users, the accessory rack and roof rack should be removed when not in use.

Periodically inspect accessory rack for damage. Replace lost, damaged or worn parts. Use only original spare parts obtained from a stocking specialist, dealer or manufacturer.

Any changes made to the roof racks and accessory racks as well as the use of spare parts or accessories other than those supplied by the manufacturer will lead to the lapsing of the manufacturer's warranty and liability for any material damage or accidents. You should observe these instructions to the letter and only use the original parts supplied.