

# **YAKIMA** LongArm Height Extension

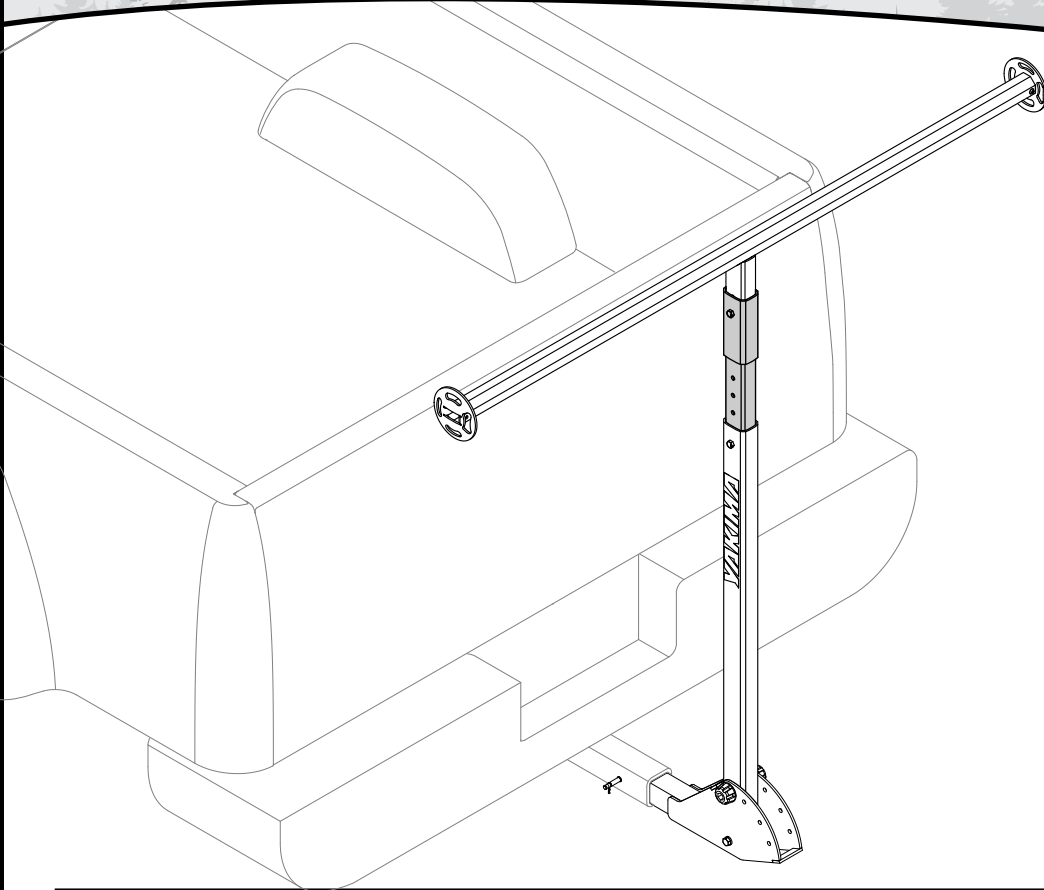

## Contents

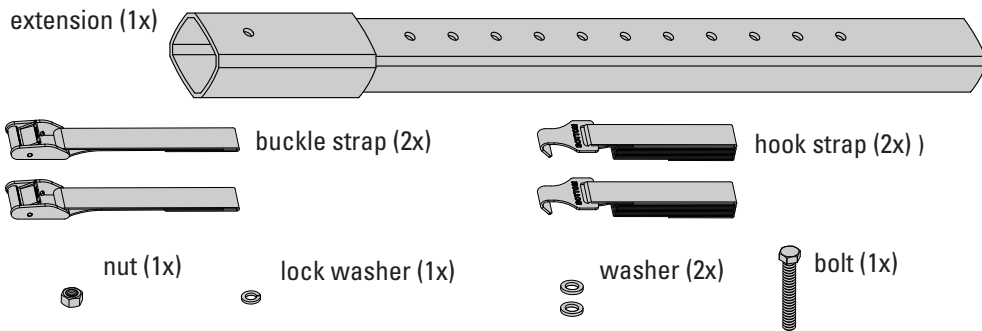

## Weight limits

Up to 165 lbs. depending on your roof rack rating.

## Available accessories

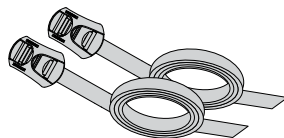

**Heavy Duty Straps**  
#8005006



**LongArm Pad**  
#8007417

# ASSEMBLE & INSTALL



Note: If you have not yet installed your LongArm follow the instructions that came with it to install it now.

**1**

Using the wrenches that came with your LongArm remove the t-bar from the mast. Retain the hardware.

Note: Lower LongArm to make installation easier.

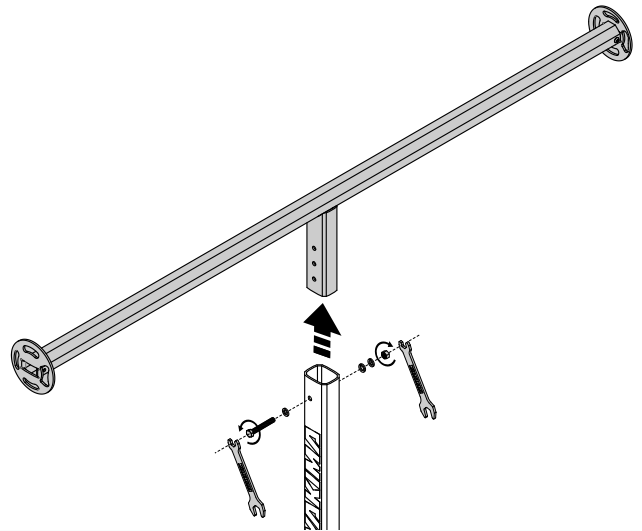
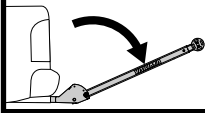

**2**

Install the LongArm Extension into LongArm.

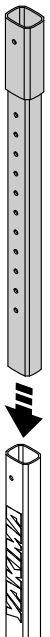

**3**

**10 ft-lb**

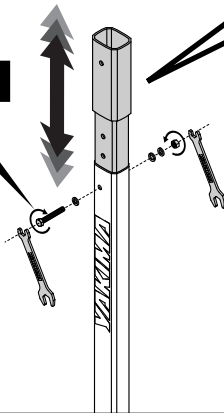

Choose the appropriate hole so that LongArm is level with your crossbar (consider the height of the t-bar in step 4). Use 2 wrenches to tighten the hardware.

**4**

Insert the t-bar into the extender. Reinstall the hardware you removed in step 1, and tighten using 2 wrenches.

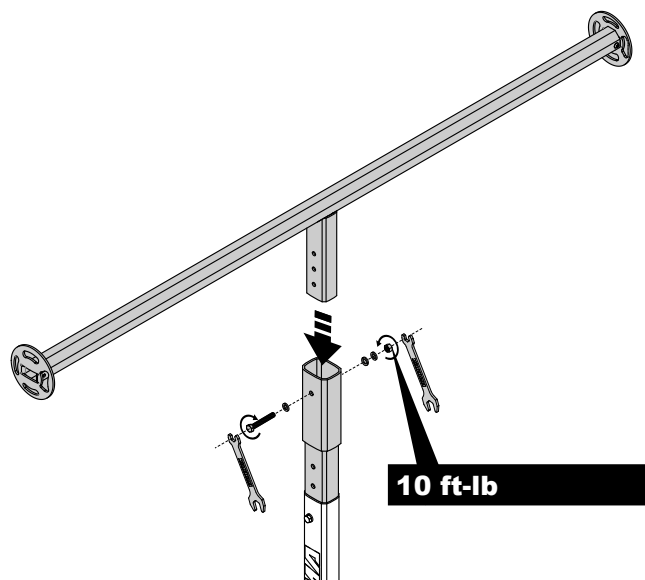

**5**

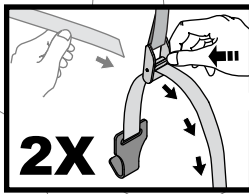
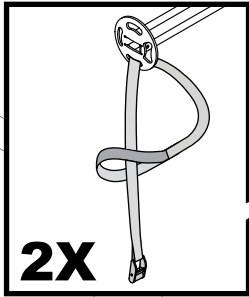

Feed the buckle strap through the endcap, and through its loop. Then thread the hook straps through the buckles.

**6**

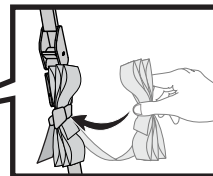

Attach the hooks to the loops on your hitch receiver. Pull firmly to tighten, and secure the strap ends.

# LOADING

Predetermine what works best for your vehicle and gear. If adding or moving a roof rack system, follow your tower instructions to do so.

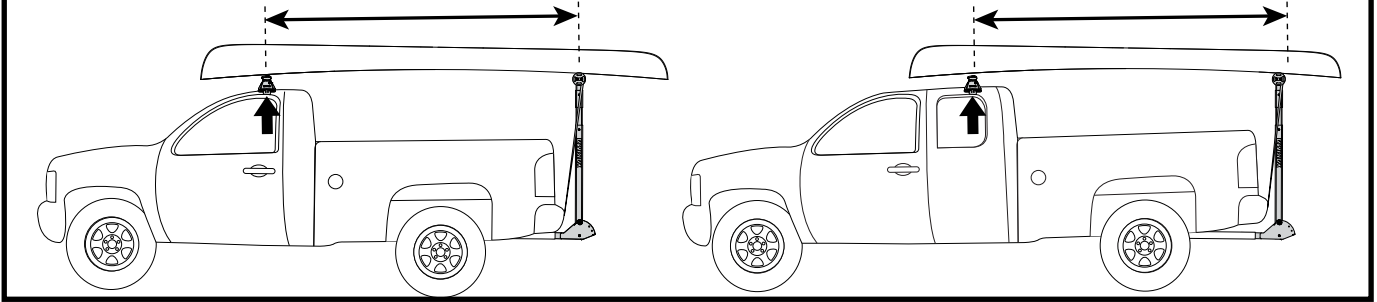

## General guidelines

- Center the load.
- Each end of any load must be tied down.
- Straps are sold separately.
- Secure loose strap ends.
- Use the endcaps to tie down wide loads.
- Attach the LongArm flag to the end of the load.

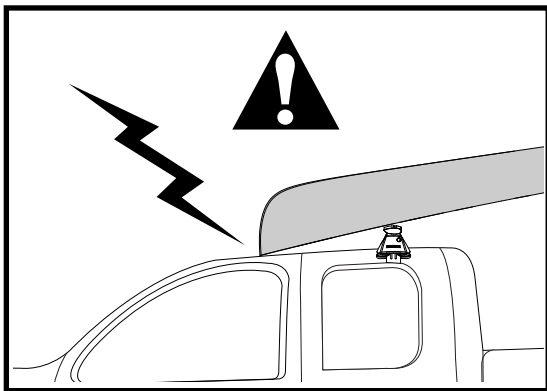
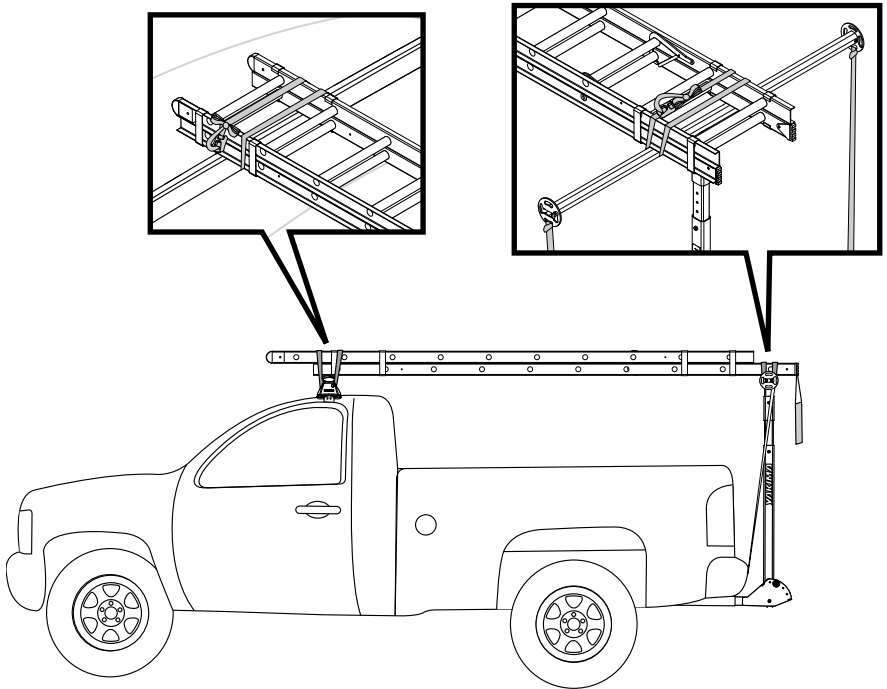

Use the anchor leash to secure the flag to the end of your load.

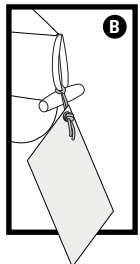
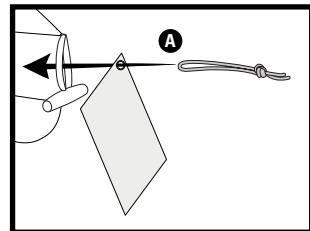

## MAINTENANCE

Use non-water soluble lubricant on screws. Use a soft cloth with water and mild detergent to clean the product.

## WARNING



**Be sure all hardware is secured according to instructions. Attachment hardware can loosen over time. Check before each use, and tighten if necessary.**

## IMPORTANT!



**Be sure to read all the warnings and warranty information contained in the insert accompanying these instructions!**

## WEIGHT LIMITS

**Not more than 165 lbs. (75kg) unless otherwise noted.**

## LONG LOADS



**Any load extending over the windshield (except luggage boxes) must be secured to both the front and rear of the vehicle, in addition to the rack. Failure to do so can result in property damage, personal injury or death.**

**KEEP THESE INSTRUCTIONS!**

## IMPORTANT WARNINGS

### **Rack Installation**

Inadequately secured loads and incorrectly mounted roof racks and accessory racks can come loose during travel and cause serious accidents! Therefore, installation, handling and use must be carried out in accordance with product and vehicle instructions.

In addition to these instructions, review the mounting instructions for the roof rack accessories and the operating instructions of the vehicle.

These instructions should be kept together with the vehicle's operating instructions and carried in the vehicle when in use and en route.

For roof racks that do not specify the distance between the front and rear crossbars, the distance shall be at least 24 inches or as large as possible. Please note that changes (e.g. additional drill holes) to the base rack's attachment system are not permissible.

Check attachment hardware and load for tight fit and function:

- Before the start of any journey.
- After driving a short distance (30 miles or 30 minutes) following rack or load install.
- At regular intervals on longer journeys, or on bad terrain.
- After interruption of a journey during which the vehicle was left unsupervised (check for damage due to outside intervention).

### **Rack Loading**

Do not exceed the maximum load specified for the roof rack, accessory rack or the maximum load recommended by the vehicle manufacturer.

**Max Roof Load = weight of roof rack + weight of accessory racks + weight of load.**

The roof rack or accessory rack may not project over the gutter. For cars without gutters over the outer edge, refer to local or national regulations.

Load shall be uniformly distributed with the lowest possible center of gravity.

Load should not substantially extend beyond the loading surface of the roof rack.

### **Vehicle Driving and Regulations**

The speed driven must be suited to the load transported and to official speed limits. In the absence of any speed limits, we recommend a maximum speed of 80 mph (130 km/h).

When transporting any load, the speed of the vehicle must take into account all conditions such as the state of the road, the surface of the road, traffic conditions, wind, etc. Vehicle handling, cornering, braking and sensitivity to side winds will change with the addition of roof top loads.

Off-road driving is not recommended and could result in damage to your vehicle or your gear.

### **Maintenance**

The accessory rack should be carefully cleaned and maintained, particularly during the winter months. Use only a solution of water and standard car wash liquid without any alcohol, bleach or ammonium additives.

Periodically inspect accessory rack for damage. Replace lost, damaged or worn parts. Use only original spare parts obtained from a stocking specialist, dealer or manufacturer.

Any changes made to the roof racks and accessory racks as well as the use of spare parts or accessories other than those supplied by the manufacturer will lead to the lapsing of the manufacturer's warranty and liability for any material damage or accidents. You should observe these instructions to the letter and only use the original parts supplied.