

# **YAKIMA**

## Spare Tire

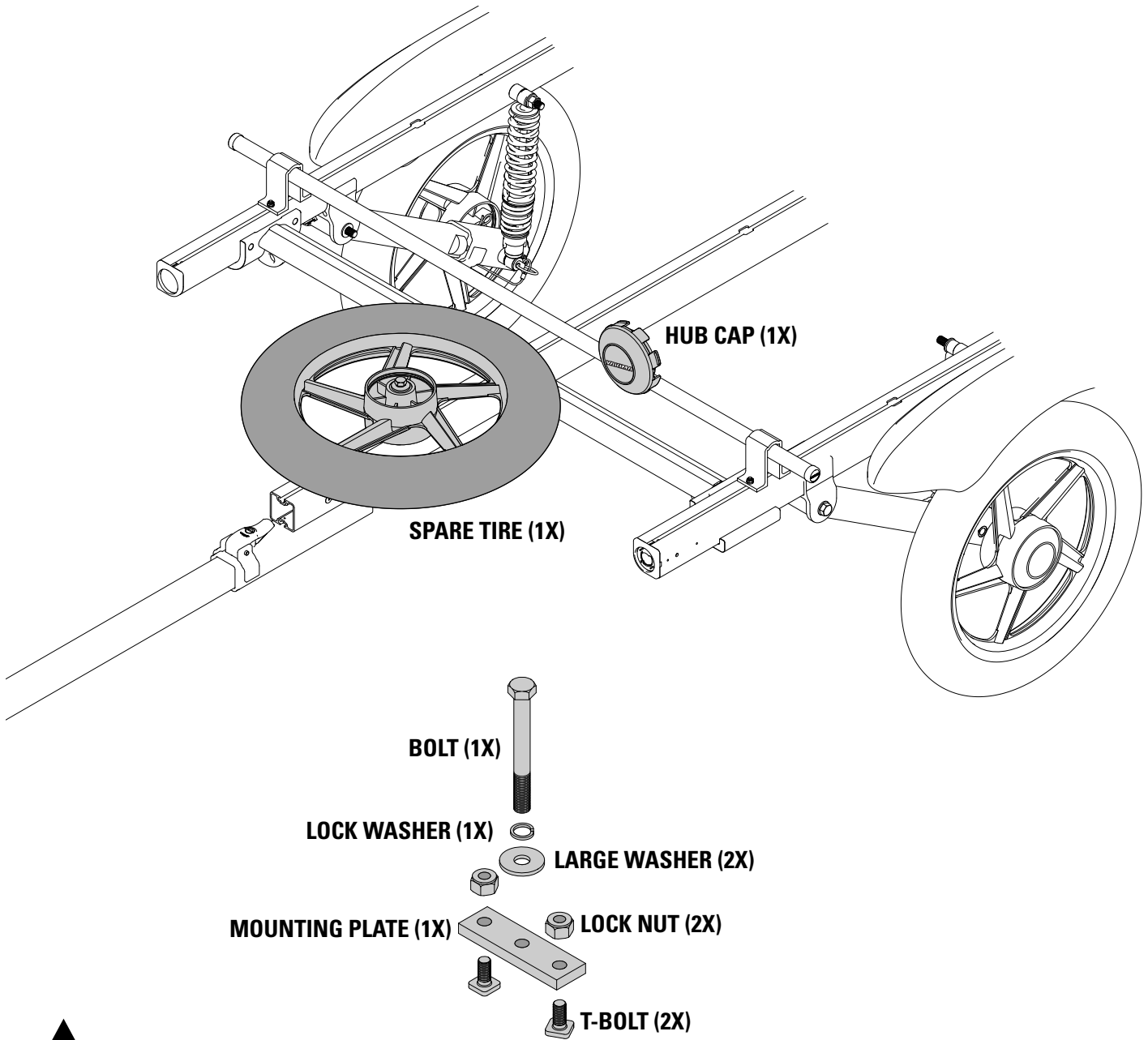

### **IMPORTANT WARNING**

**IT IS CRITICAL THAT ALL YAKIMA RACKS AND ACCESSORIES BE PROPERLY AND SECURELY ATTACHED TO YOUR VEHICLE. IMPROPER ATTACHMENT COULD RESULT IN AN AUTOMOBILE ACCIDENT, AND COULD CAUSE SERIOUS BODILY INJURY OR DEATH TO YOU OR TO OTHERS. YOU ARE RESPONSIBLE FOR SECURING THE RACKS AND ACCESSORIES TO YOUR CAR, CHECKING THE ATTACHMENTS PRIOR TO USE, AND PERIODICALLY INSPECTING THE PRODUCTS FOR ADJUSTMENT, WEAR, AND DAMAGE. THEREFORE, YOU MUST READ AND UNDERSTAND ALL OF THE INSTRUCTIONS AND CAUTIONS SUPPLIED WITH YOUR YAKIMA PRODUCT PRIOR TO INSTALLATION OR USE. IF YOU DO NOT UNDERSTAND ALL OF THE INSTRUCTIONS AND CAUTIONS, OR IF YOU HAVE NO MECHANICAL EXPERIENCE AND ARE NOT THOROUGHLY FAMILIAR WITH THE INSTALLATION PROCEDURES, YOU SHOULD HAVE THE PRODUCT INSTALLED BY A PROFESSIONAL INSTALLER.**

### 1 Remove reflector.

Using a crosshead screwdriver remove the screw that secures the front reflector, and remove the reflector. Set both the screw and reflector aside.

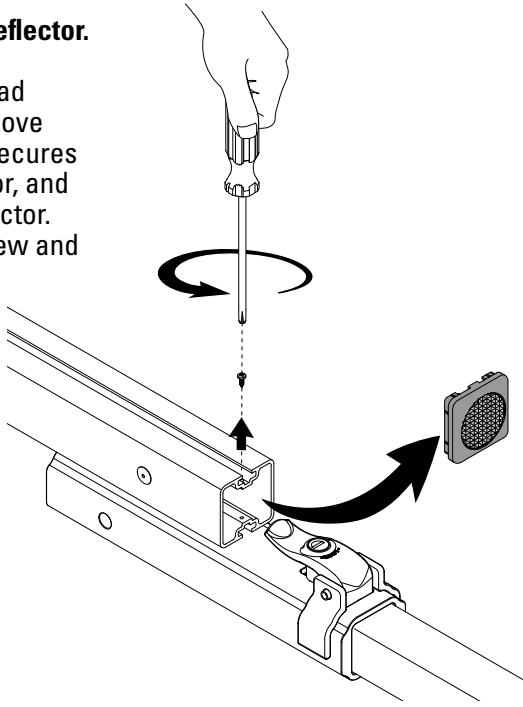

### 2 Insert T-Bolts into slot.

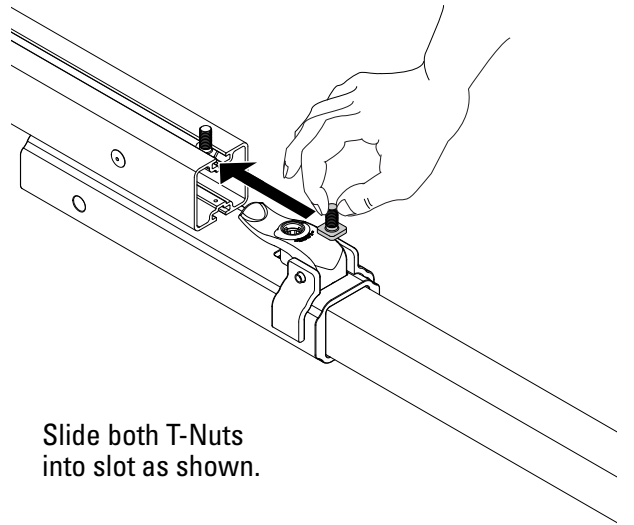

Slide both T-Nuts into slot as shown.

### 3 Install mounting plate.

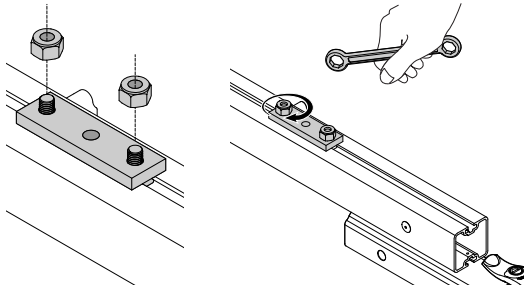

Place mounting plate onto T-Bolts. Thread lock nuts onto T-Bolts. Tighten down nuts.

### 4 Replace reflector.

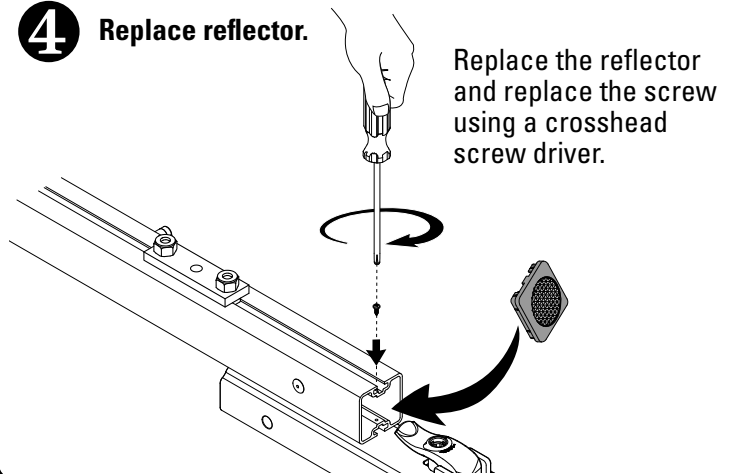

Replace the reflector and replace the screw using a crosshead screw driver.

### 5 Bolt wheel to mounting bracket.

Insert bolt through lock washer, large washer, spare tire, and into mounting bracket. Tighten down the *Spare Tire* using firm resistance.

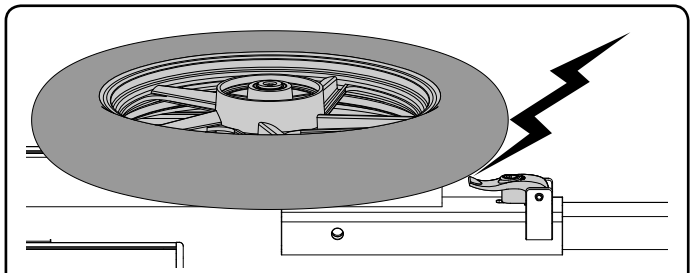
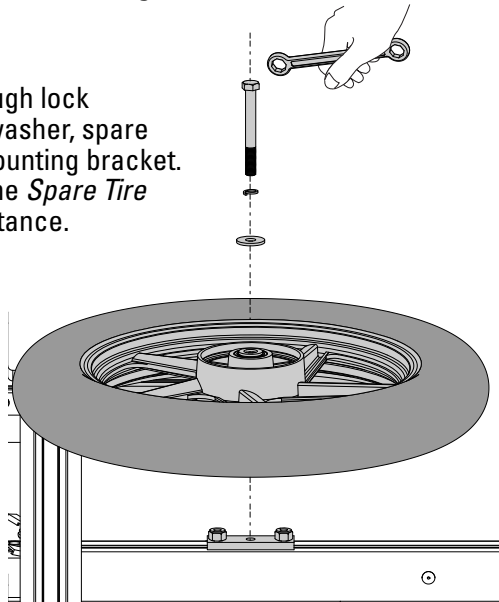

#### WARNING

Be sure there is no interference between the *Spare Tire* and the black lever. If there is interference you must move the mounting bracket back until there is no interference.

## 6 Install hubcap.

Press the hub cap firmly into place. It should seat flush to the rim.

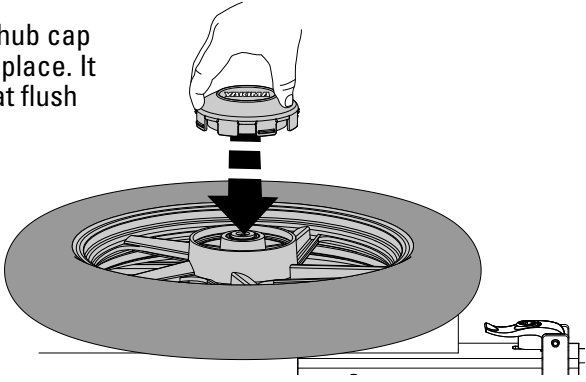

Note: To remove the hubcap use a flathead screwdriver to gently pry it from the rim.

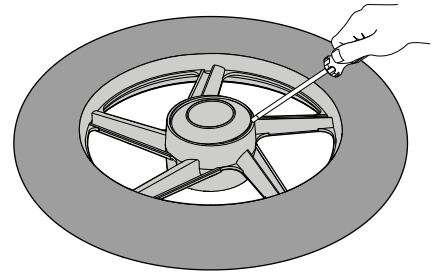

### OPTIONAL SPARE TIRE PLACEMENT

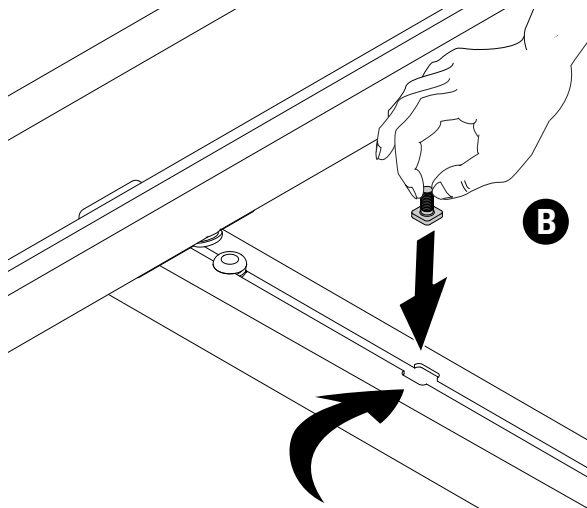
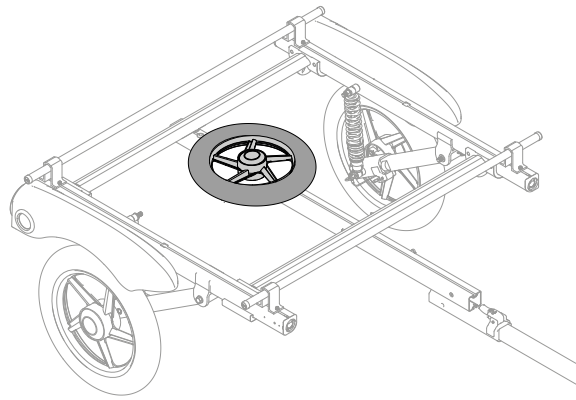
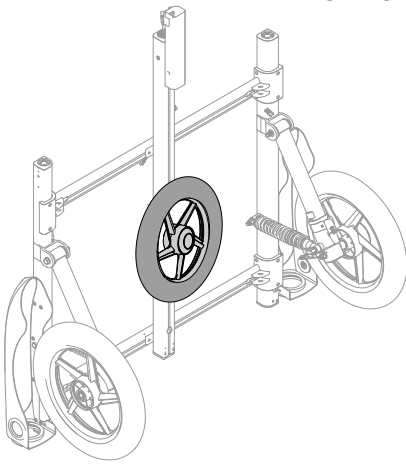

**B** Insert the two T-Bolts through the entry point, and then proceed with steps 3 through 5 to secure the mounting bracket, and install your spare tire.

**A** For either mounting option locate the T-Bolt entry point on the center rail of your trailer. There is an entry point on both the top and bottom sides of the center rail.



Your tires should be inflated to 32-40 psi cold (see tire sidewall ratings).  
**Test with a tire gauge and periodically check for your safety.**

