

# YAKIMA

# Q TOWERS

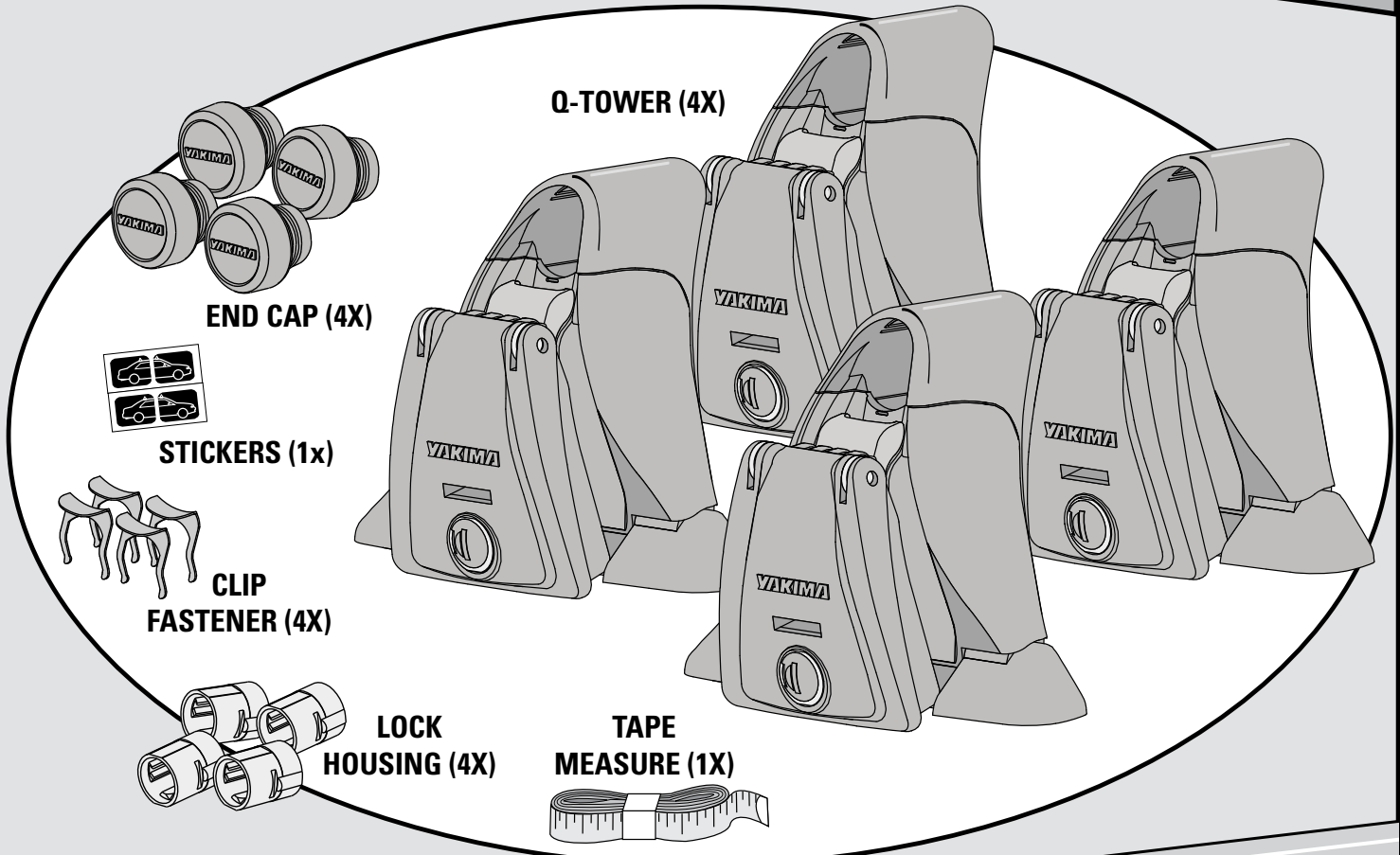

**Vehicle-specific Q-Clips and crossbars are sold separately in pairs.**

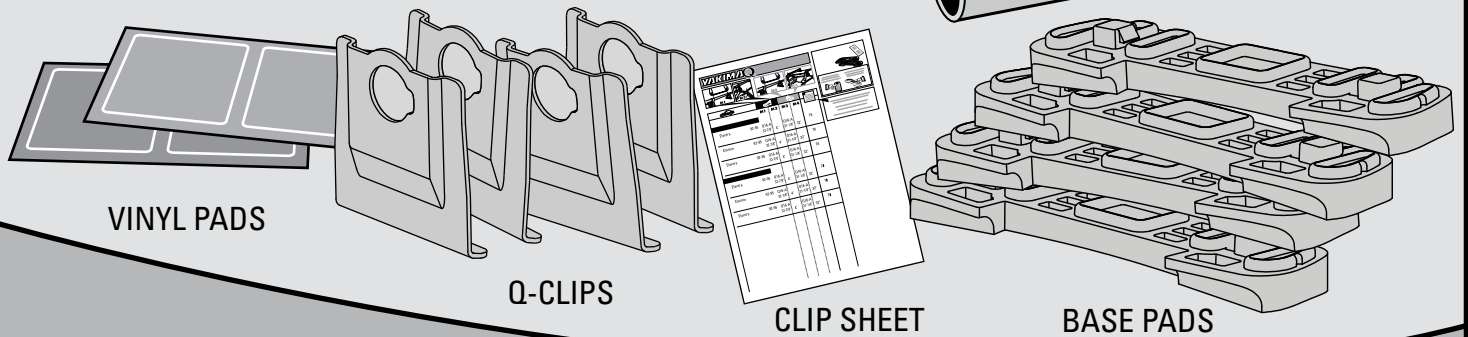
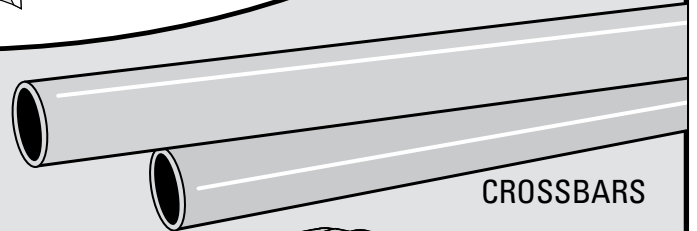

## IMPORTANT WARNING

IT IS CRITICAL THAT ALL YAKIMA RACKS AND ACCESSORIES BE PROPERLY AND SECURELY ATTACHED TO YOUR VEHICLE. IMPROPER ATTACHMENT COULD RESULT IN AN AUTOMOBILE ACCIDENT, AND COULD CAUSE SERIOUS BODILY INJURY OR DEATH TO YOU OR TO OTHERS. YOU ARE RESPONSIBLE FOR SECURING THE RACKS AND ACCESSORIES TO YOUR CAR, CHECKING THE ATTACHMENTS PRIOR TO USE, AND PERIODICALLY INSPECTING THE PRODUCTS FOR ADJUSTMENT, WEAR, AND DAMAGE. THEREFORE, YOU MUST READ AND UNDERSTAND ALL OF THE INSTRUCTIONS AND CAUTIONS SUPPLIED WITH YOUR YAKIMA PRODUCT PRIOR TO INSTALLATION OR USE. IF YOU DO NOT UNDERSTAND ALL OF THE INSTRUCTIONS AND CAUTIONS, OR IF YOU HAVE NO MECHANICAL EXPERIENCE AND ARE NOT THOROUGHLY FAMILIAR WITH THE INSTALLATION PROCEDURES, YOU SHOULD HAVE THE PRODUCT INSTALLED BY A PROFESSIONAL INSTALLER.

Overview

Prepare for installation

Install front towers

Install rear towers

Perform safety checks



## Anatomy of the Q-Tower.

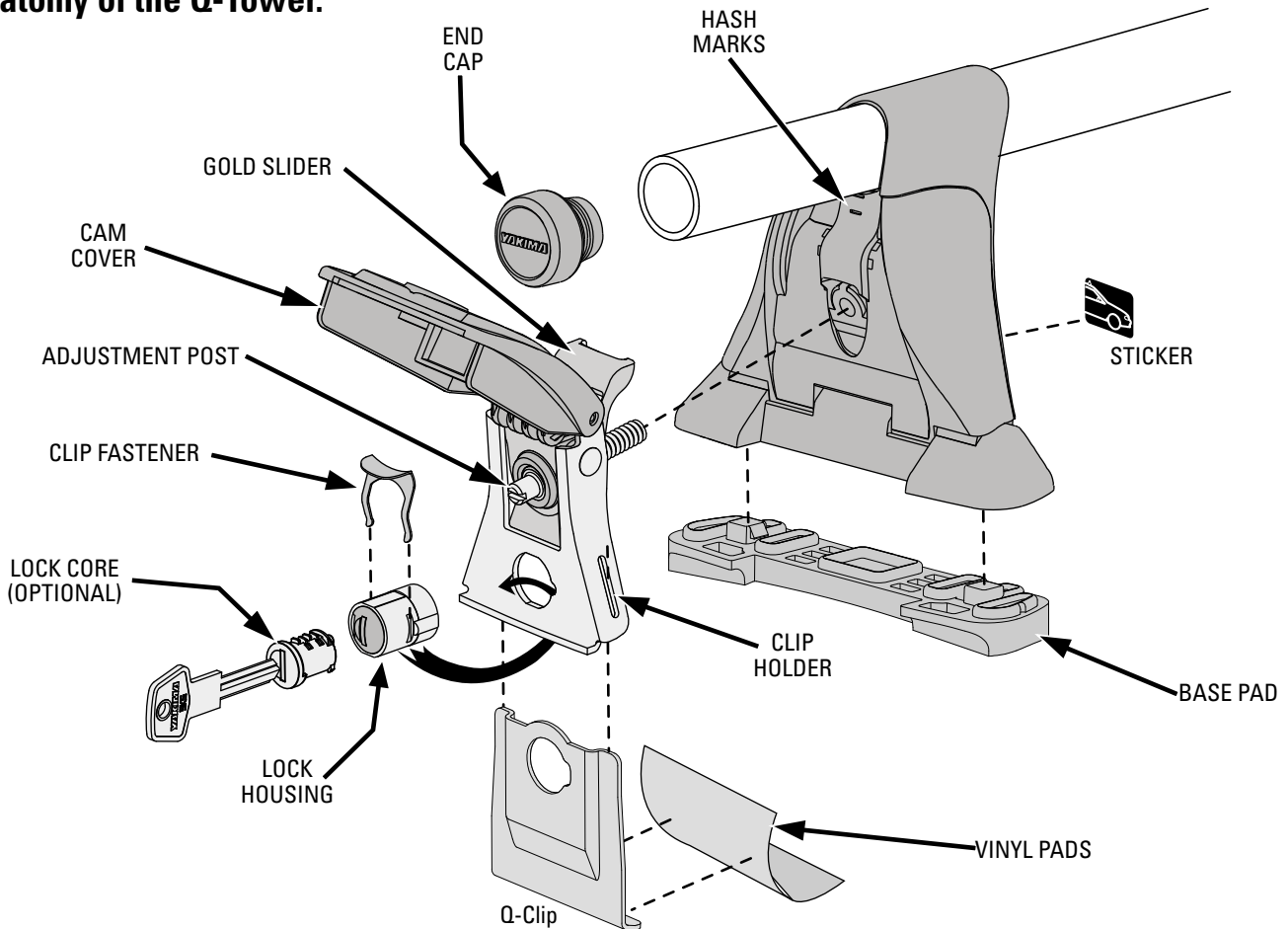

## Q-Clip families.

There are several shapes and sizes of Q-Clips, but they all fall into five Q-Clip categories. Every vehicle needs a specific Q Clip to install Q-Towers. For this reason Q-Clips must be purchased separately. Examples of the five different categories of Q Clips are depicted below.

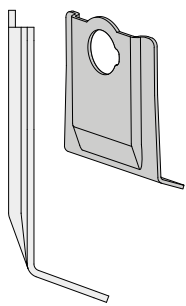

BLADED

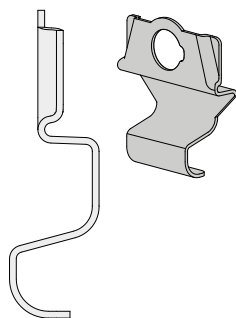

AIRCRAFT

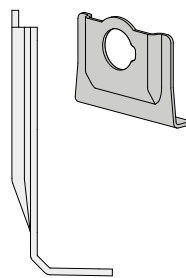

RAIN GUTTER

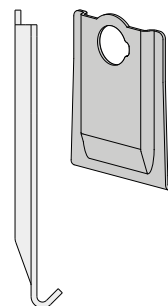

HOOK

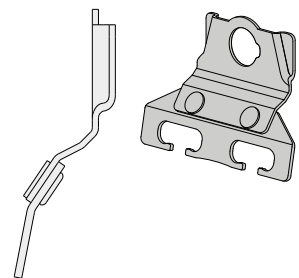

OEM  
(ATTACHES TO FACTORY  
INSTALLED VEHICLE FEATURE)

Overview

Prepare for installation

Install front towers

Install rear towers

Perform safety checks

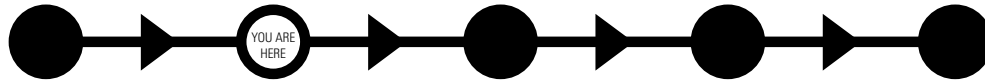

# 1 Remove the covers.

Unscrew the *adjustment posts* to remove the *covers* from each of your four towers.

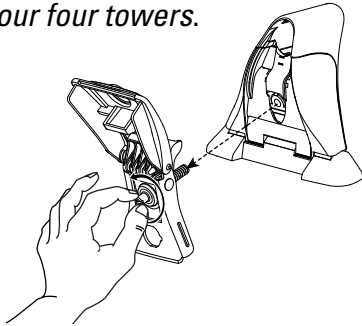

# 2 Open towers.

Open each tower to access the *tower screw*.

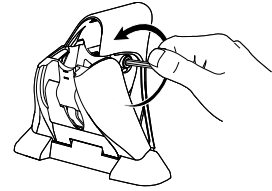
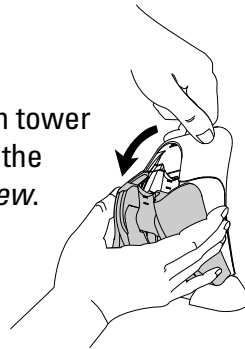

Loosen all four tower screws until the crossbar can fit through the tower (refer to next step).

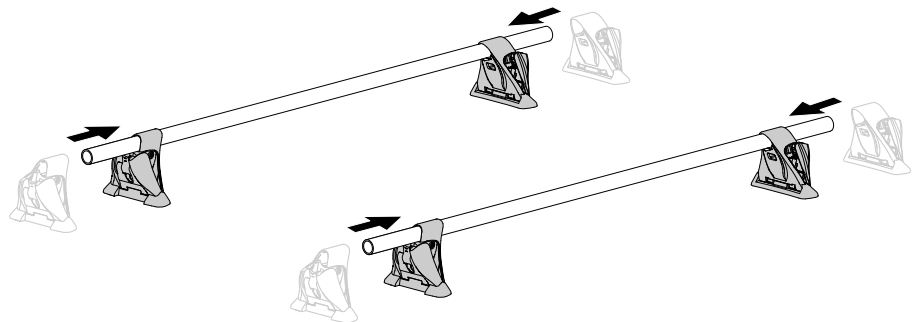

# 3 Slide towers onto bars.

Slide two towers onto each crossbar.



# 4 Find Your 4 M's (measurements).

Locate the precise measurements for your car on the Q-clip sheet.

				
MAKE	M1	M2	M3	M4

Write down your four measurements in the spaces provided to the right. Keep these instructions in a safe place for future reference.

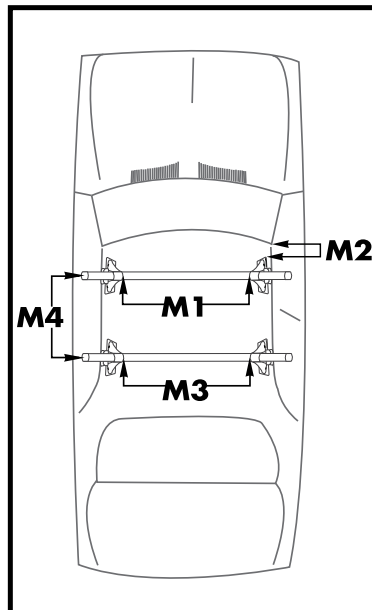

YOUR CAR:

M1=

M2=

M3=

M4=

## 5 Set M1, M3 and center bars.

Note: Set measurements on a flat surface away from vehicle.

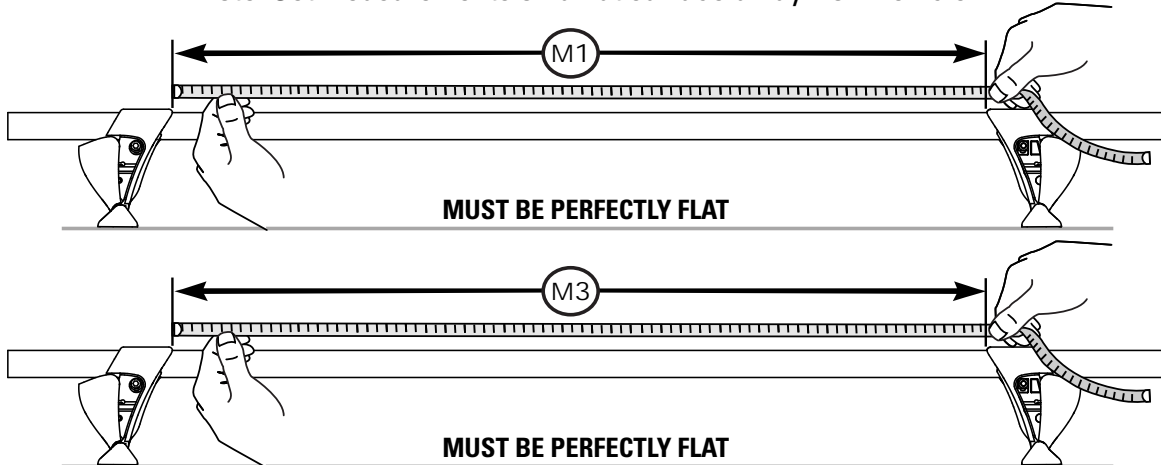

 Pull the measuring tape tight to ensure accurate measurements. Measurements must be accurate to within 1/8" (3.2 mm).

TIP: To center crossbar between towers after setting your measurement use this technique. While pushing downward and rotating the crossbar, adjust the crossbar as needed to the left or right. Double check your M1 measurement and adjust if necessary.

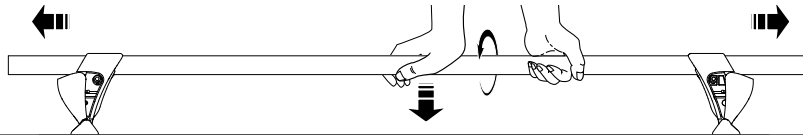

## 6 Tighten tower/bar assembly.



Be sure to not move the towers.

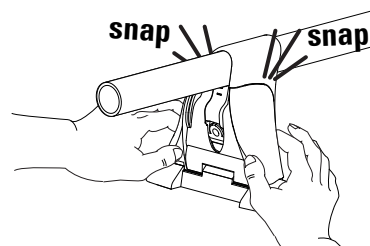
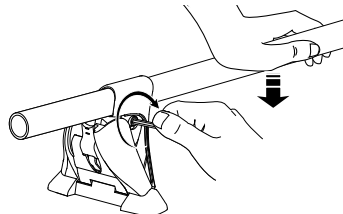

Snap the covers shut.

## 7 Label the towers.

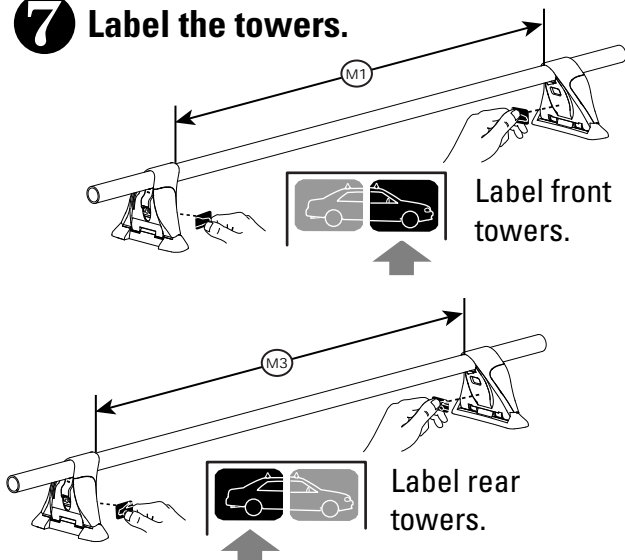

## 8 Install end caps and correct pads.

Attach correct pads. Some cars require different pads on front (M1) and rear (M3). Pad letter is located in the center of each pad.



Keep the pads clean and free of debris. Clean pads as necessary, and keep them clean by not setting them on a dirty surface.

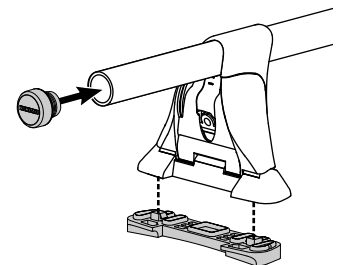

Overview

Prepare for installation

Install front towers

Install rear towers

Perform safety checks



## 9 Position Front Towers.

- Clean car roof where towers will set.
- Set the assembly on the roof.

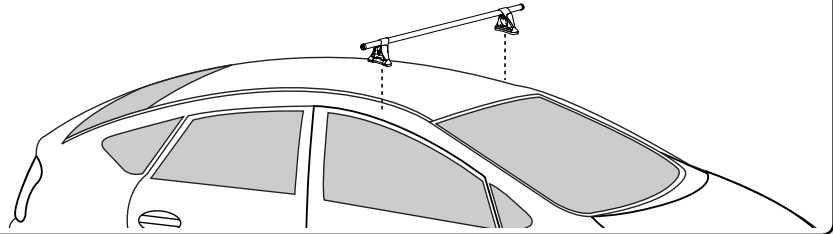

## 10 Set M2.

- USE THE M2 MEASUREMENT you identified in step 4.
- Measure the shortest distance from leading edge of tower base to nearest painted roofline corner.
- Once positioned DO NOT MOVE.

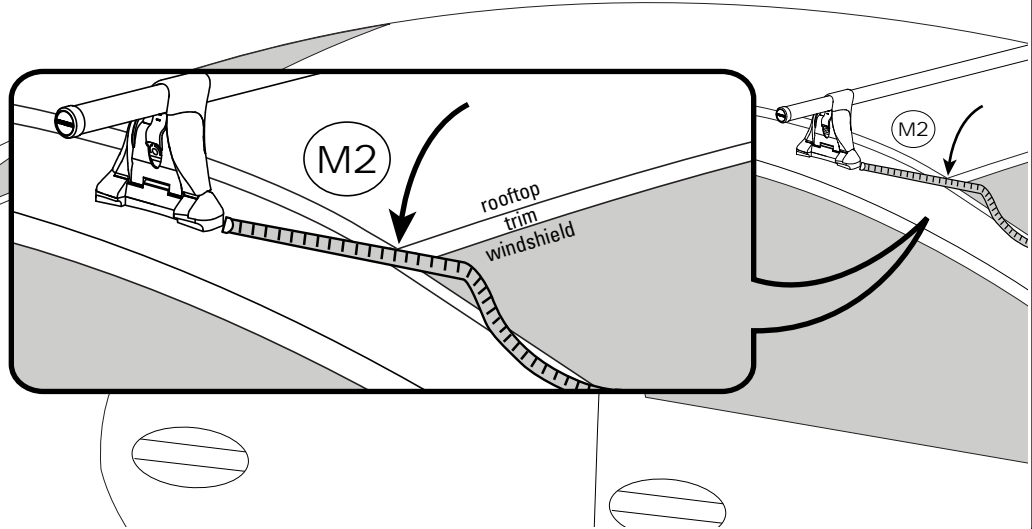

TIP: Verify this measurement repeatedly during installation.

## 11 Center front rack on vehicle.

Center racks side to side by measuring from the door frame to tower base. Measuring points and distances on both sides must be equal.

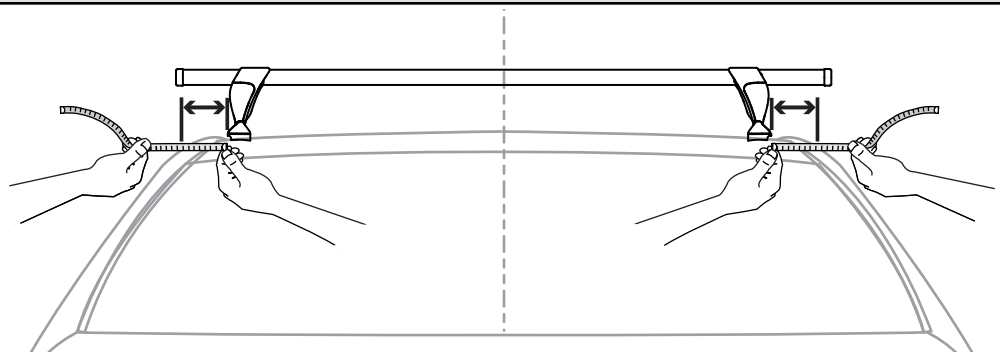

## 12 Apply vinyl pads to front clips.

- Apply black vinyl pads wherever clip touches car paint. Be sure to cover clip edges. Trim if necessary.

MAKE	M1	M2	M3	M4
Model	Year	clip	clip	clip
		in.	in.	in.

- Reference Clip Sheet instructions to see which clips are the front clips for your car.

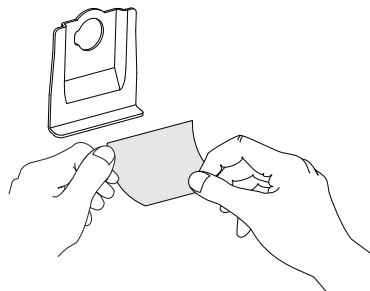

Some cars require different clips at front and rear. Clip number is located here.

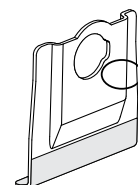

### 13 Assemble *front* Q-Clips and lock housings.

- Insert the correct clip through the slits in clip holder.
- Insert lock housing through holes in clip and clip holder.

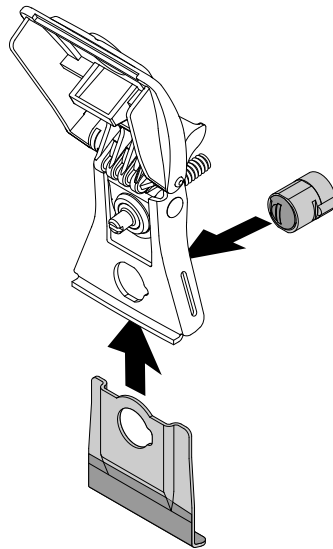

- Place clip fastener over lock housing to secure assembly.

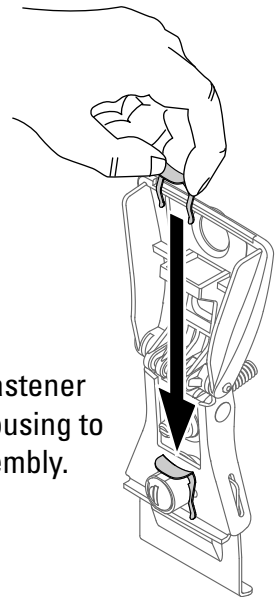

### 14 Loosely attach cam covers.



**DO NOT MOVE TOWERS!** If you bump the towers you'll need to go back and reposition them (step 9).

- Open both driver's side and passenger side front doors.
- Carefully thread adjustment post on to tower to get the cover loosely attached (2 turns max).
- Repeat for other side.

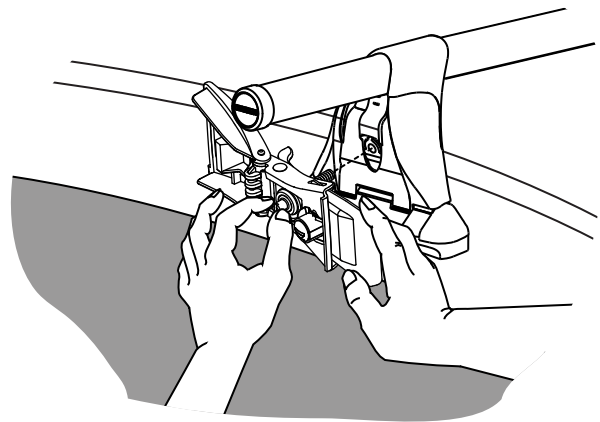

- Carefully push the clip in place up against the door frame. **DO NOT MOVE THE TOWERS.**
- Using the adjustment post, take slack out of the system until the cam cover closes **easily** while holding the clip to the door frame. **DO NOT FULLY TIGHTEN.**
- Repeat for other side.

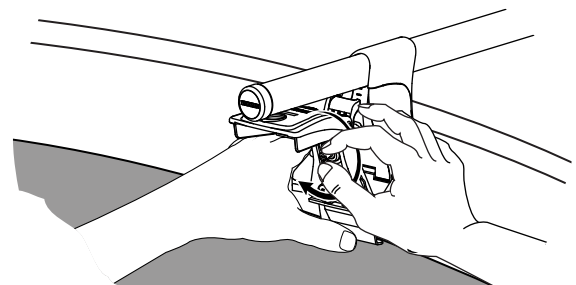
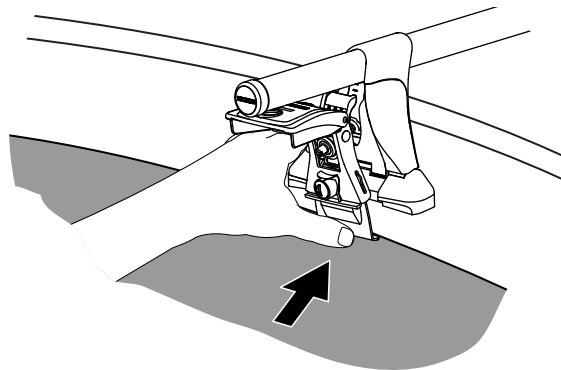

**Check your M2 again. Correct if needed (step 10).**



## Install System

- 15a** **The objective:** Your installation will be complete once you achieve balanced tower tension.

### BALANCED TOWER TENSION REQUIREMENTS

1. Cam Cover closes with firm and equal resistance on both sides of the vehicle.
2. Gold Slider positions are equal on both sides of the vehicle. Reference hash marks on tower body.
3. **For Bladed Clips Only:** Gold Slider position must also be ON OR BETWEEN HASH MARKS.

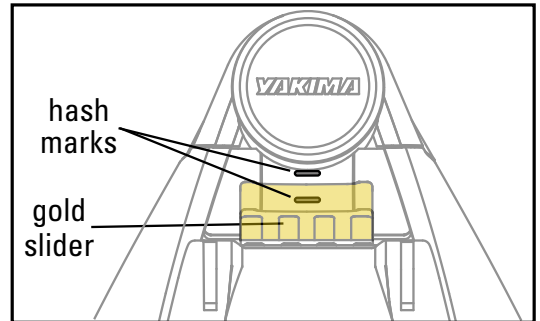

bladed clips  
(see page 2)

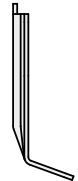

- 15b** **The technique:** Slowly tighten your towers by turning the adjustment posts clockwise one full turn at a time, alternating from driver's side tower to passenger's side tower. **Close the Cam Cover after each adjustment.** Only one Cam Cover can be open at a time.

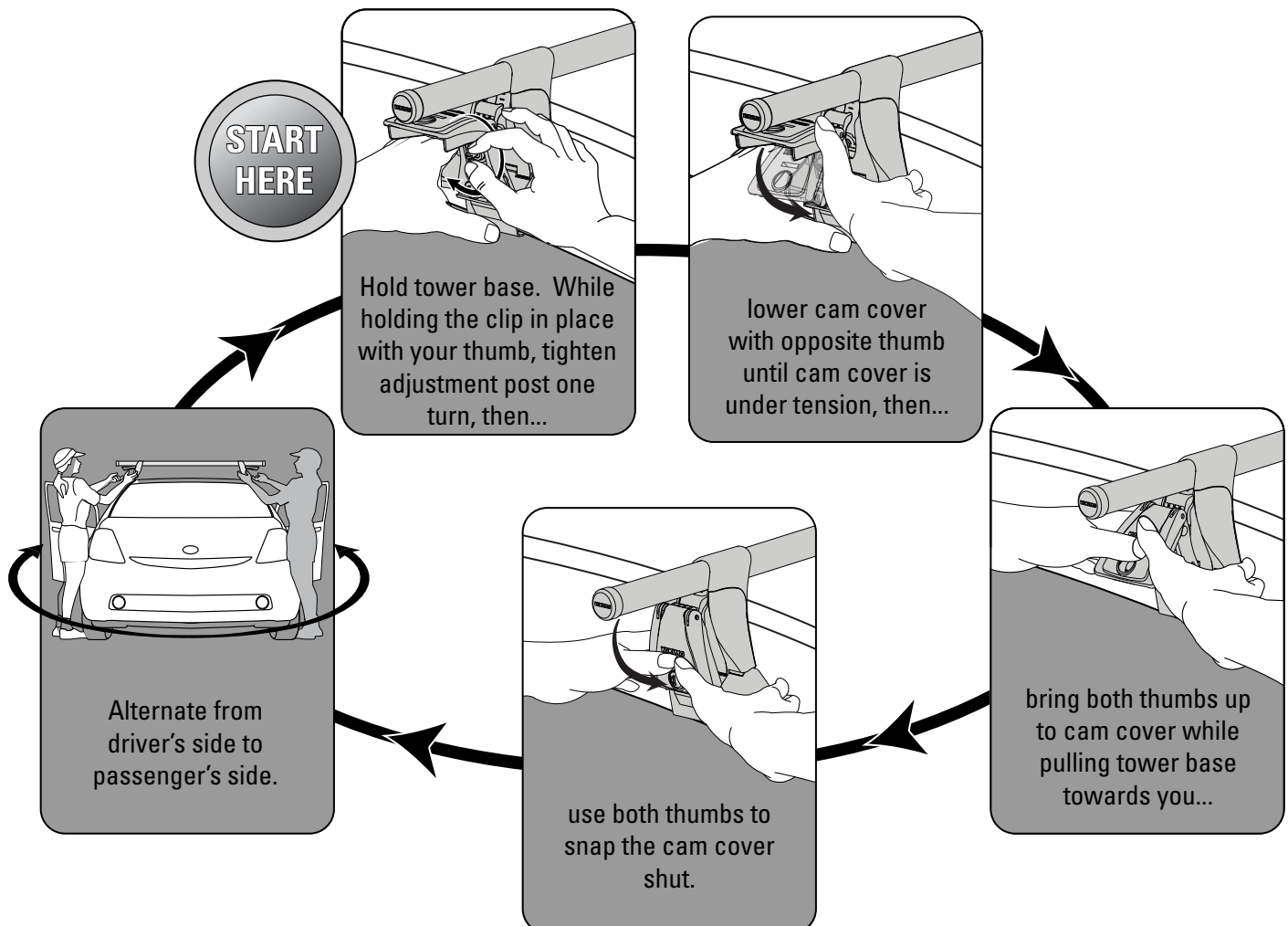

**Perform this technique on both the driver side and passenger side in an alternating fashion until you achieve balanced tower tension.**

## 16 Perform Safety Checks With Car Doors Open.

### CHECK EACH CLIP!

Pull each clip away from car. **PULL HARD!**

Repeat twice.  
**Clip should not move on second pull.**

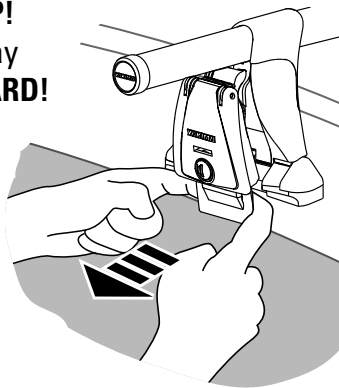

### CHECK EACH TOWER!

Grip the bar inboard to towers; push and pull using only arm strength.

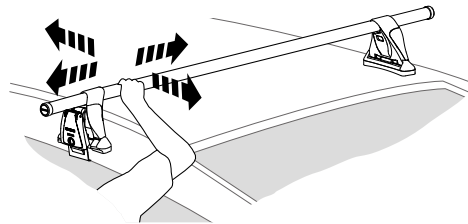

If any of the clips or Towers move, reset M2, check gold slider positions, and fine tune by tightening adjustment posts gradually (step 15b). If there is still movement after fine tuning, verify the M1.

Overview

Prepare for installation

Install front towers

Install rear towers

Perform safety checks



## 17 Position rear towers.

- Clean car roof where towers will set.
- Set the assembly on the roof.

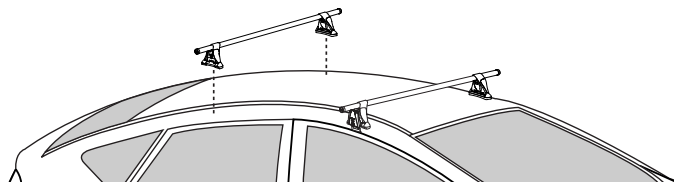

## 18 Set Measurement Four.

- USE THE M4 MEASUREMENT you identified in step 4.
- Measure from center of bar to center of bar.
- Once positioned DO NOT MOVE.

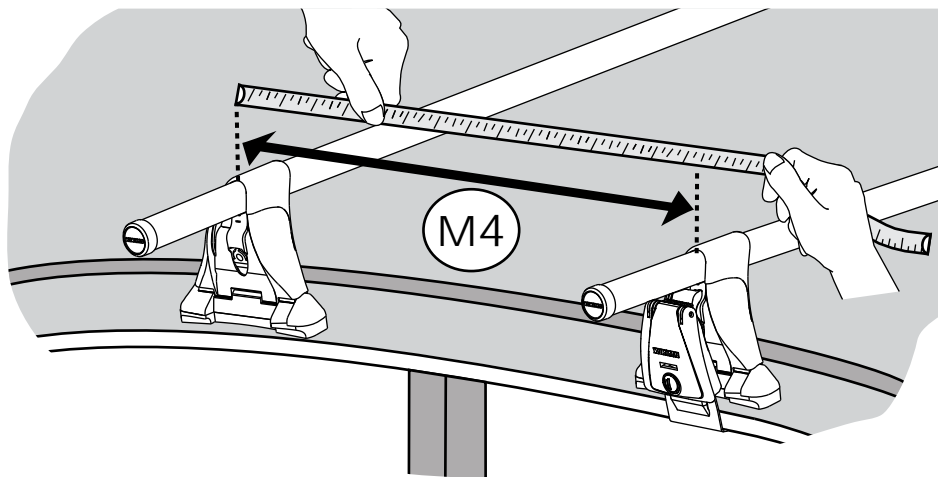

NOTE: This measurement must be accurate for proper installation.

## 19 Center rear rack on vehicle.

Center racks side to side by measuring from the door frame to tower base. Measuring points and distances on both sides must be equal.

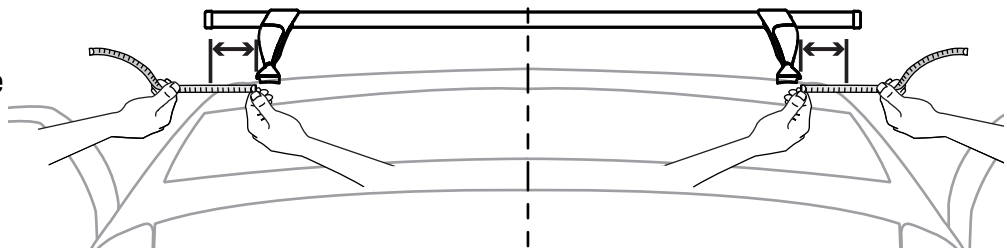



## 20 Install rear system: Repeat steps 12 through 16.

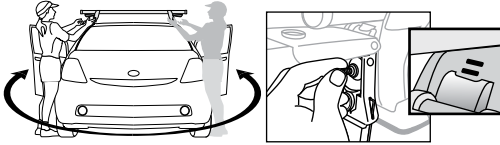
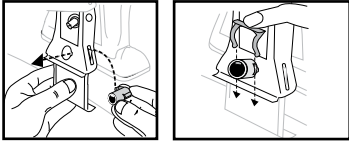

Step 12: Line *rear* clips with vinyl pads.  
Step 13: Assemble *rear* Q-Clips and lock housings.  
Step 14: Attach cam covers.  
Step 15: Increase the tower tensions equally (gold slider positions must match each other!).  
Step 16: Perform Safety Checks With Car Doors Open.  
**Covers must close with firm resistance.**  
**CHECK EACH CLIP...CHECK EACH TOWER.**



**FAILURE TO CHECK CLIPS AND TOWERS BEFORE DRIVING AWAY CAN RESULT IN PROPERTY DAMAGE, PERSONAL INJURY, OR DEATH.**

Overview

Prepare for installation

Install front towers

Install rear towers

Perform safety checks



## 21 Perform Safety Checks With Car Doors Open.

### CHECK EACH CLIP!

Pull each clip away from car. **PULL HARD!**

Repeat twice.  
**Clip should not move on second pull.**

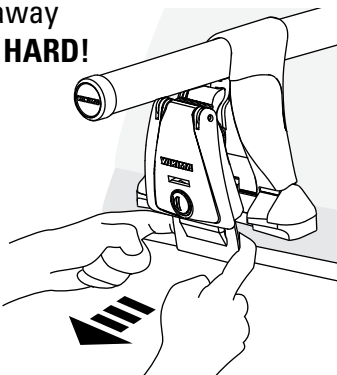

### CHECK EACH TOWER!

Grip the bar inboard to towers; push and pull using only arm strength.

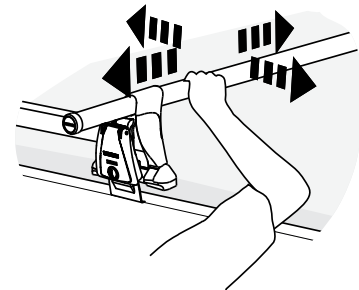

If any of the clips or Towers move, reset M4, check gold slider positions, and fine tune by tightening adjustment posts gradually (step 15b). If there is still movement after fine tuning, verify the M3.

Once installed, easy on easy off without tools.

### REMOVING THE SYSTEM

Unlock towers and open cam covers.  
Lift rack up and off (do not disassemble).

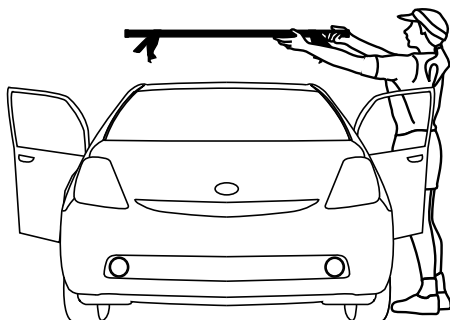

### INSTALLING RACKS AGAIN

- Open cam covers.
- Clean roof and place towers at M2 and M4 positions; measure carefully.
- Make sure clips are seated properly, then close cam covers with firm resistance.

**PERFORM SAFETY CHECKS ON ALL TOWERS AND CLIPS AFTER EVERY INSTALLATION! (Step 21)**



**Failure to check clips and towers before driving away can result in property damage, personal injury, or death.**

**22 LOCK THE TOWERS.**

If you have purchased lock cores, install them according to lock instructions.

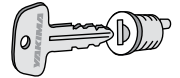

**23 Tie down LONG LOADS**

Any load extending over the windshield (except luggage boxes) must be secured to both the front and rear of the vehicle, in addition to the rack. Failure to do so can result in property damage, personal injury or death.

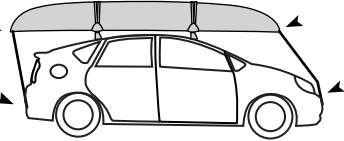

**IMPORTANT!**

**Be sure to read all the warnings and warranty information contained in the insert accompanying these instructions!**



**WEIGHT LIMITS**

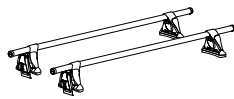

THIS PRODUCT  
(15.5 lbs. / 7 kg)

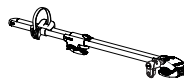

ANY ACCESSORIES



LOAD



Not more than 165 lbs. (75 kg) unless otherwise noted.

**REAR HATCH**

Some longer loads may prevent the rear hatch from fully opening.

**USE CAUTION WHEN OPENING YOUR HATCH.**

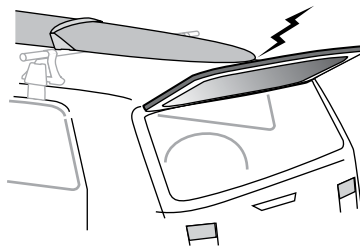

**SUN ROOF**

**USE CAUTION WHEN OPENING SUNROOF.**

Sunroof may interfere with crossbars or accessories.

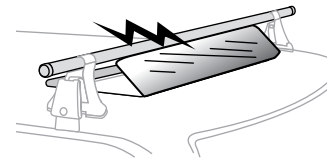

**FACTORY LUGGAGE CARRIER**

If the vehicle is equipped with a factory luggage carrier, it may interfere with some accessories.

**ANTENNA**

Antenna on the roof may need to be removed to prevent interference with the rack or long loads.



**WARNING: Be sure all hardware is secured according to instructions. Attachment hardware can loosen over time. Check before each use, and tighten if necessary.**

**KEEP THESE INSTRUCTIONS!**