

PART NO. SU294

TOLERANCES UNLESS SPECIFIED		
TWO PLACE DECIMALS +/- .015	THREE PLACE DECIMALS +/- .005	ANGLES +/- 1°

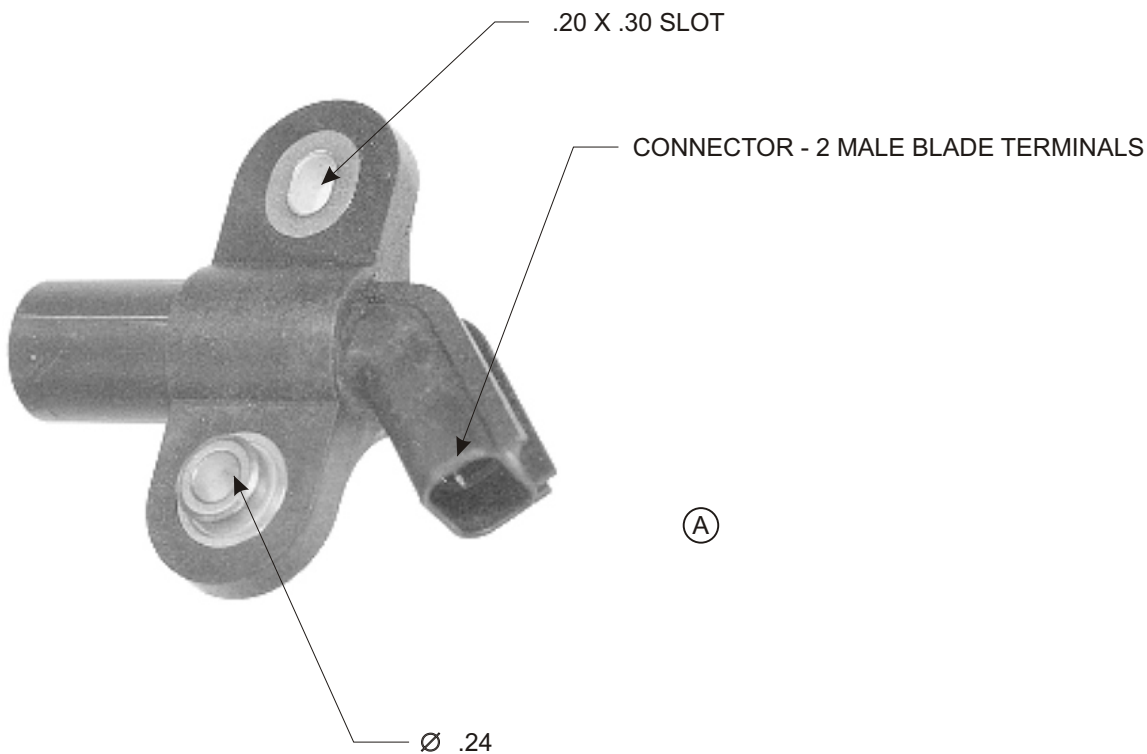

REPLACES FORD. # F4SZ-6C315-A (B)

NOTE:
RESISTANCE BETWEEN BLADE
TERMINALS TO BE 660 ±60 .

					MATERIAL	N/A	SCALE	NTS	WELLS		
							DATE	1-7-98		DWN. BY	CWS
B	REMOVED O.E. #	28768	7-13-05	GC	FINISH	N/A	ENGINEER	1-7-98	TWF	TITLE	CRANKSHAFT POSITION SENSOR
A	REMOVED DIM'S	28731	7-1-05	GC			APPROVED	1-7-98	JSK	PART NO.	SU294
	RELEASED	21052A	6-29-98	CS			PURCH.	<input type="checkbox"/>	PROD.	<input type="checkbox"/>	
L	REVISION	CN	DATE	BY	CAD REF.	N/A	MODEL				