

PART NO. 784

TOLERANCES UNLESS SPECIFIED		
TWO PLACE DECIMALS +/- .015	THREE PLACE DECIMALS +/- .005	ANGLES +/- 1°

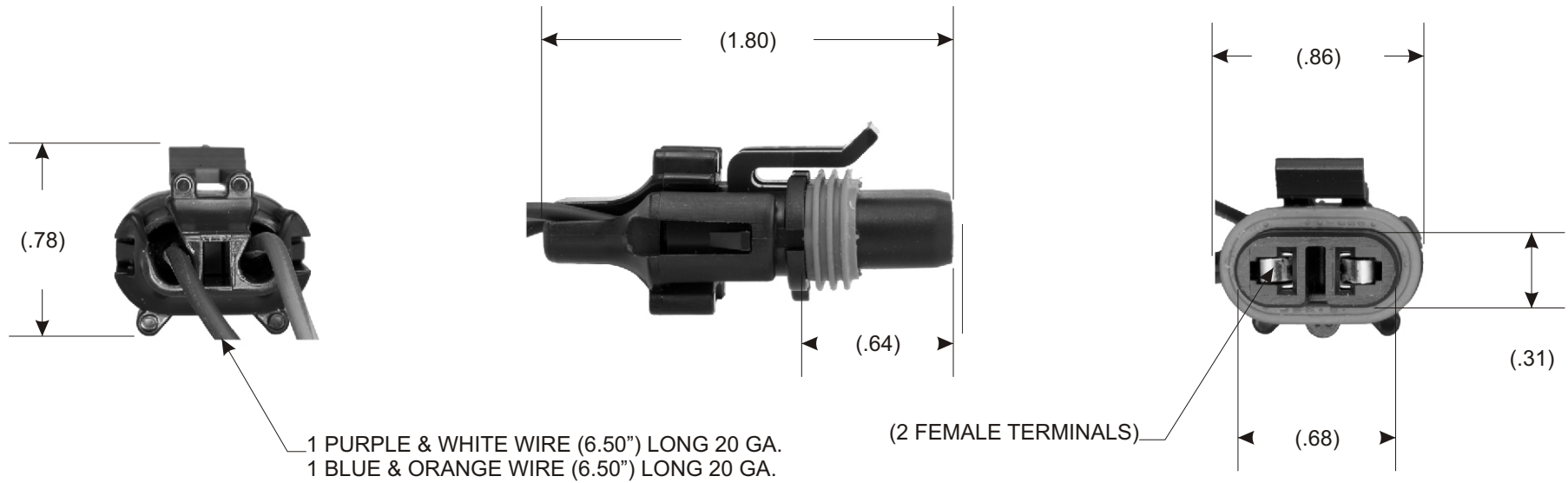

REPLACE O.E. # 96-7583

NOTE: REPAIR HARNESS - HALOGEN  
BULB # 880, 885, 890, & 892.

					MATERIAL	N/A	SCALE	NTS				
					FINISH	N/A	DATE	12-09-08		DWN. BY	JRJ	
							ENGINEER	12-09-08			DAL	
							APPROVED	12-09-08			TDS	
	RELEASED DRAWING	31439A	12-09-08	JRJ			PURCH.	<input type="checkbox"/>	PROD.	<input type="checkbox"/>	TITLE	PIGTAIL ASSEMBLY
L	REVISION	CN	DATE	BY	CAD REF.	N/A	MODEL	N/A	PART NO.	784		