

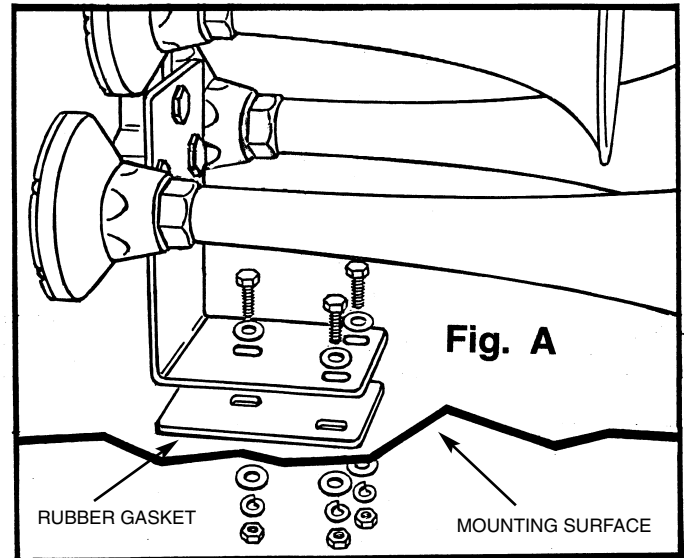

INSTALLATION INSTRUCTIONS For Models 839, 849 & 852 Train Horns

HORN INSTALLATION (Fig. A)

1. Locate a mounting location that is a solid metal surface such as the vehicle's frame or chassis to help prevent excessive vibration, which could damage the horn. **IMPORTANT:** Do not mount horn on a plastic fender well or on flexible material. For best results, the front of the horn should be unobstructed so that the sound can carry straight ahead.
2. Use the base of the horn as a template, mark the hole locations and drill to size 5/16".
3. Place the gasket between the mounting surface and the base of the horn.
4. Secure the horn with the hardware provided and tighten evenly.



LANYARD VALVE and HOSE INSTALLATION (Fig. B)

5. Mount the lanyard valve in a convenient location so that its chain can be easily reached by the driver. Using the lanyard valve as a template, drill holes and mount with screws provided.

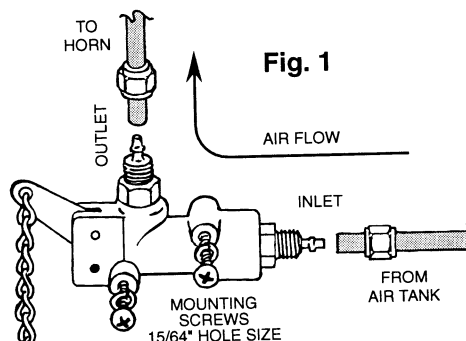

6. Using the 1/4" plastic hose provided, cut to size so to connect the vehicle's air tank to the inlet fitting of the lanyard valve. Place the brass nut and compression fitting onto the hose. Push the hose into the female fitting of the lanyard valve and tighten the brass nut. **CAUTION:** Do not over tighten the brass nut.
7. Using the 1/4" plastic hose provided, cut to size so to connect the lanyard valve to the inlet fitting of the horn. Place the brass nut onto the hose. Push the hose on to the male fitting of the lanyard valve and tighten the brass nut. **CAUTION:** Do not over tighten the brass nut.
8. Place the brass nut, then the compression fitting onto the other end of the air hose. Push the tube onto the horns male inlet fitting. Thread the nut onto the fitting and tighten. **CAUTION:** Do not over tighten the brass nut.

IMPORTANT: NEVER INSTALL THE HORN TO AN AIR TANK THAT CONTROLS THE AIR BRAKES OR ANY OTHER CRITICAL OPERATING SYSTEM.