



INSTALLATION INSTRUCTIONS for Model 809

The addition of a Wolo horn for your vehicle will provide an extra level of sound. The Wolo name, with more than twenty years of experience is your guarantee of a superior horn product. Each horn and compressor is bench tested before it is packaged. Precision workmanship and quality components will assure years of reliable service.

AIR HORN INSTALLATION

1. Locate the desired area you wish to mount the dual trumpet air horn. For best results, the front of the horn should be unobstructed so that the sound can carry straight ahead.
2. Use the horn's rubber gasket as a template, mark hole locations and drill to size shown in Fig. A.
3. Secure the horn with hardware provided. Tighten evenly to provide a good water tight seal. Fig. A.

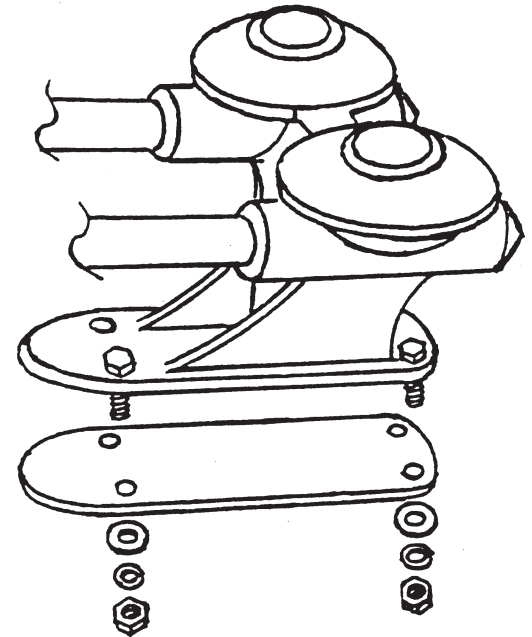
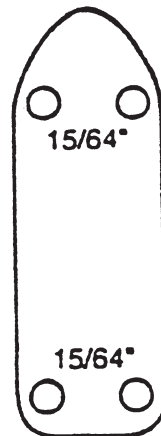

Fig. A

COMPRESSOR INSTALLATION

4. Install the compressor in a dry location.

IMPORTANT: Compressor must be mounted not further than 8 to 10 inches from the trumpet for proper sound.

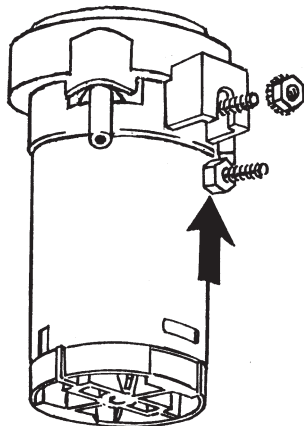

Fig. B

5. To secure the compressor drill one 5/16" hole. When possible, mount the compressor (air outlet at top). Install the head of the bolt into the slot on the side of the compressor. Secure the compressor to the vehicle using the lock washer/nut provided as shown in Fig. B.
6. Using the plastic tubing provided, cut to length and connect the compressor to the horn's inlet fitting between the trumpets as shown in Fig. C.

Caution: Avoid making any kinks or sharp bends in plastic tubing that will reduce air flow and alter the horn's sound.

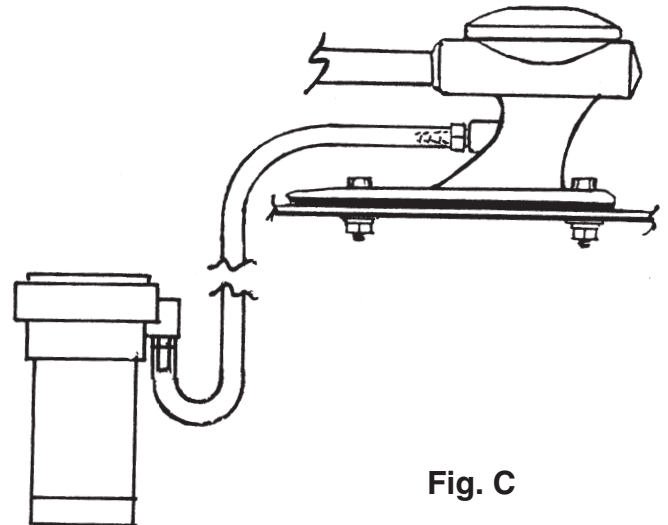

Fig. C

WIRING

7. Electrical Connection – Using Vehicle Factory Wiring

IMPORTANT: You are not required to use the relay supplied with the kit because the vehicle factory system already has a relay.

- A. For two (2) wire systems: If vehicle's factory horn has two (2) terminals, simply transfer wires to the compressor's terminals. **IMPORTANT:** when testing the horn if compressor turns on but the horn does not sound, reverse the wires connected to the compressor.
- B. For one (1) wire systems: If vehicle's factory horn has one (1) terminal, simply transfer the wire to the compressor's positive (+) terminal.
- C. Using wire provided or heavier 16-gauge, the compressor's negative terminal is connected to any metal body bolt. A ground connection should be free of rust and paint.

Electrical Connections for a New Horn Button Switch

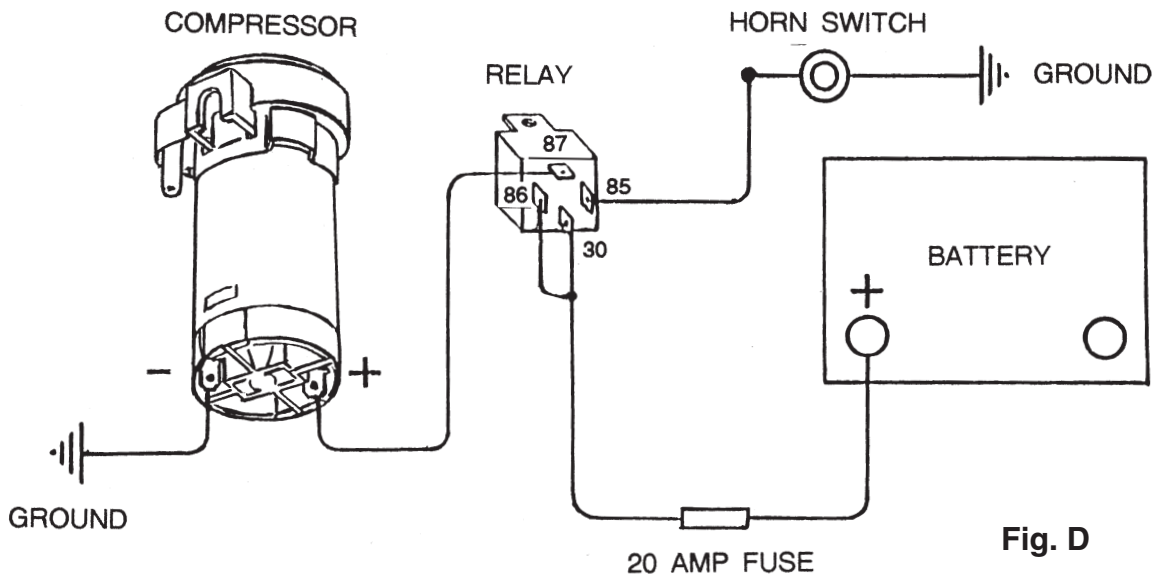

Fig. D

8. Electrical Connection For A New Horn Button Switch (Included) (See Fig. D)

- A. The relay that is supplied in kit must be used to power compressor. Find a location near the compressor that is dry.
IMPORTANT: Using wire provided or heavier 16-gauge.
- B. Connect to horn switch terminal (-) ground. (Place a wire under any metal body bolt that is clean of paint and rust.)
- C. Connect the other horn switch terminal to relay terminal #85.
- D. Relay terminal #30 is connected to (+) 12 volts, battery, alternator, etc. The 20 amp inline fuse provided must be used to protect your vehicle.
- E. Relay terminal #86 is connected to relay terminal #30.
- F. Relay terminal #87 is connected to the (+) terminal on the bottom of the compressor.
- G. Ground is connected to the other compressor terminal marked (-). Place a wire under any metal body bolt that is clean of paint and rust.
- H. **Recap of Terminal Connections for New Horn Switch:**
Terminals: 30/86 - the two terminals are connected to 12 volts positive (+) using a fuse.
Terminal: 85 - connect to horn switch negative (-).
Terminal: 87 - connect to positive (+) terminal of compressor.