



Maxi-Sound Horns

Models 320-2T, 325-2T, X-2000, X-2005, X-2010 & X-2015 INSTALLATION INSTRUCTIONS

MOUNTING FIG. #1

1. Remove the factory horn, and install your new Wolo horn in the same position with the opening of the horn facing downward to prevent dirt and water from entering into the horn. Secure the horn to the vehicle using the bracket and hardware provide.

IMPORTANT: For one (1) terminal factory horn system, the grounding jumper wire needs to be secured under the mounting bolt before securing horn to a metal body grounding surface.

Fig. #2-3

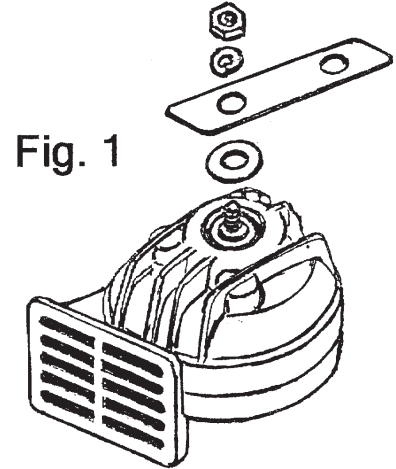

TWO (2) TERMINAL WIRING FIG. #2

2. For vehicles where the factory horn wires connect to two (2) horn terminals. Transfer the factory horn wires to each new Wolo horn. It doesn't make a difference which horn terminals are used on your new Wolo horn when transferring the wires from your factory horn. **IMPORTANT:** Always make sure that there is a 15 -amp fuse used in the horn circuit to protect the vehicle. If the wire terminals that were connected to your vehicle's factory horn doesn't connect to your new Wolo horn, 1/4" push- on insulated terminals are provided in the kit. The installation is complete and the horn is ready to be used.

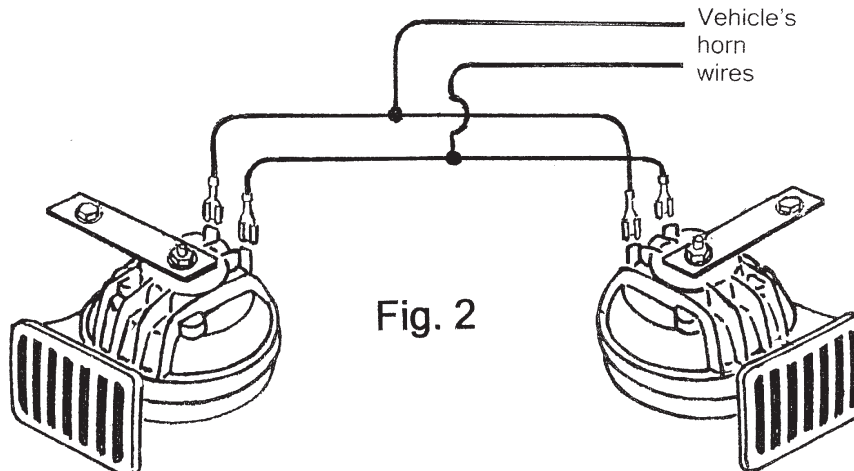

ONE (1) TERMINAL WIRING FIG. #3

3. For vehicles where the factory horn wire connects to only one (1) horn terminal. Transfer the factory horn wires to your new Wolo horn. It doesn't make a difference which horn terminal is use when transferring the wire from your factory horn.

4. Using the grounding wires supplied, place the loop end under each of the mounting bolts of the horn and firmly tighten. Make sure the horn's mounting bracket is secured to a metal body surface that is clean of paint and rust.

5. Attach each of the grounding wires female terminals, to the unused terminal of each horn. **IMPORTANT:** always make sure that there is a 15-amp fuse used in the horn circuit to protect the vehicle. Installation is complete. If the wire terminal that was connected to your vehicle's factory horn doesn't connect to your new Wolo horn, 1/4" push-on insulated terminals are provided in the kit.

