

INSTALLATION INSTRUCTIONS

For EURO EXPRESS Model 875

Your purchase of a Wolo Euro Express Train Horn is the choice to compliment your vehicle. Wolo's products are manufactured with the finest materials. Each horn is tested to ensure it meets all manufacturing specifications.

Installation of the Euro Express requires drilling into the vehicle. The installer must carefully inspect both sides of the selected locations to ensure that there are no components, wires and/or any other vehicle part that could be damaged by drilling. **IMPORTANT:** Always de-burr any drilled holes, ensuring that there are no sharp edges. Install a rubber grommet into all metal holes that the wires are being routed through.

Always refer to the vehicle's shop manual for deployment location of air bags. Never install the horn switch, wires and or components in the deployment area of any air bag. Improper installation could reduce the effectiveness of the vehicle's air bag system and or project an object that could cause serious personal injury or death to driver and passenger. The user/installer assumes all responsibility to properly access a safe mounting location, to provide ultimate safety to the driver and passengers inside the vehicle.

MOUNTING TRUMPETS: FIG. 1

1. Position each trumpet with the open end facing downward when possible, this will prevent water and dirt from entering into the trumpet's sound chamber. **CAUTION:** Always keep the trumpets at a distance not less than 6" from exhaust manifolds, any component parts that get hot and any moving parts.
2. Use the trumpet's mounting base as a template, mark the two mounting hole locations and drill to size: 5/16".
3. Place the rubber gasket provided, between the mounting surface and the horn's mounting base.
4. Secure the trumpet to the mounting location using the hardware provided.
5. Repeat the same mounting procedure for the other two trumpets. **NOTE:** The Euro Express is a high-pressure horn, for ease of installation, the trumpets do not have to be mounted in the same location.

MOUNTING ELECTRIC SOLENOID: Fig. 2

6. The mounting location for electric solenoid valve needs to be in a dry location and safe from engine and exhaust manifold heat.
7. Remove the brass outlet air fitting from the solenoid by turning the fitting counter-clockwise. (**NOTE:** Only the outlet fitting can be separated from the valve).
8. Use the solenoid's mounting bracket as a template and mark the location of the mounting holes. Drill to size: 1/4".
9. Secure the mounting bracket using the hardware provided. The solenoid can be rotated on the bracket to best fit your space (Fig. 2A).
10. Secure the solenoid to the mounting bracket by threading the brass outlet fitting (removed in step number 7) back into the solenoid and tighten using a wrench.

IMPORTANT: The black plastic housing that has the two 1/4" male electrical terminals, can be repositioned by loosening the nut located on the top of the solenoid. Reposition if required and tighten the nut (Fig. 2A).

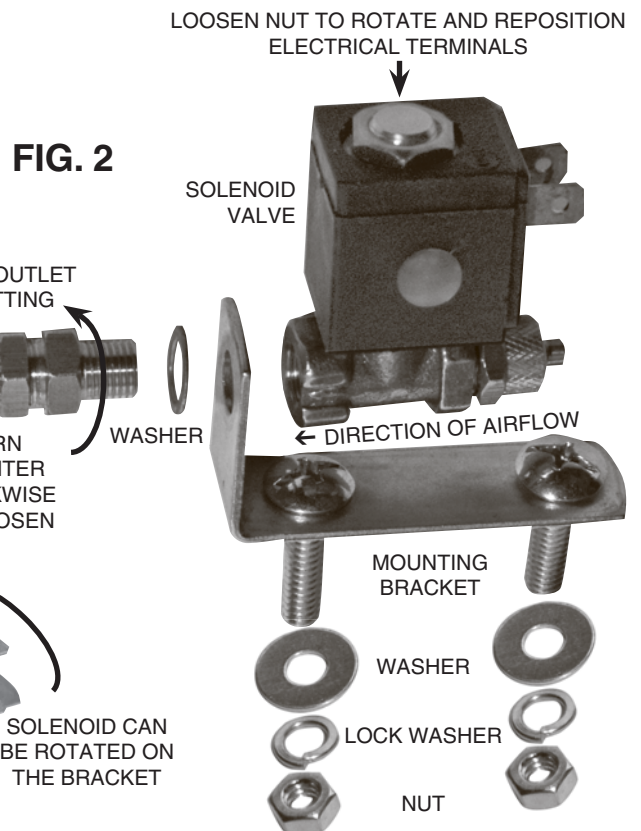
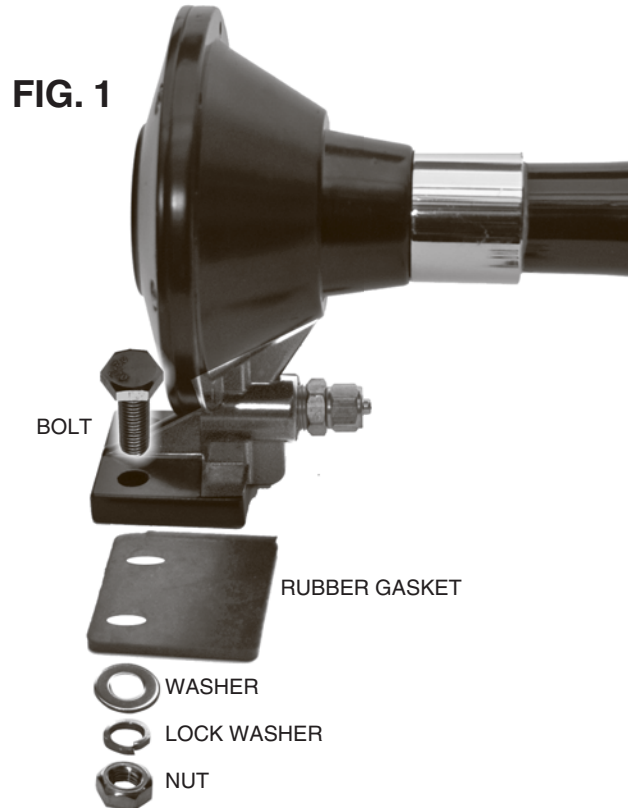
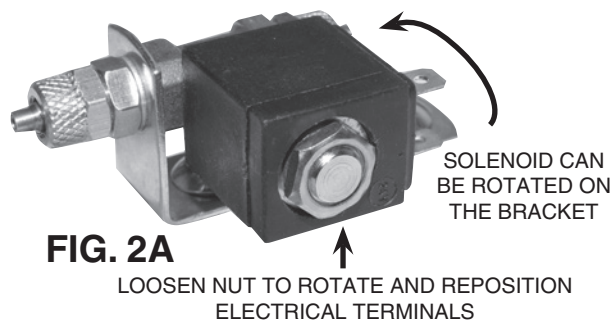

HIGH PRESSURE HOSE CONNECTIONS: Fig. 3

11. Cut the 1/4" high-pressure hose provided, to length so to connect the trumpet to the three way air splitter.
12. Secure the 1/4" high-pressure hose to the trumpet by removing the brass nut from the air fitting. Slide the nut onto the 1/4" high-pressure hose.
13. Push the 1/4" high-pressure hose onto the trumpet's brass fitting.
14. Tighten the brass nut to the air fitting. **CAUTION:** Do not over tighten brass nut.
15. The other end of the high-pressure hose is pushed into one of the ports of the three-way air splitter. The hose can be removed anytime from the air splitter by pushing inward on the black ring that the hose was pushed into. **NOTE:** To ensure a leak free installation, make sure the end of the hose is cut evenly.
16. Repeat the same procedure to connect the 1/4" hose to the other two trumpets.
17. Cut the 1/4" high-pressure hose provided to length so to connect the solenoid's air outlet to the three-way air splitter.
18. The three-way air splitter can be secured to the vehicle; mark hole locations and drill to size: 3/32". Secure air splitter using the two sheet metal screws provided.

IMPORTANT: There is an arrow ← on the solenoid, which shows the direction of the airflow entering and exiting the valve.

19. Cut the 1/4" high-pressure hose provided to length so to connect the solenoid's inlet to the air storage tank.

IMPORTANT: Make sure that the onboard air system has no pressure before attempting to connect hose to tank.

IMPORTANT: NEVER INSTALL THE HORN TO AN AIR TANK THAT CONTROLS THE AIR BRAKES OR ANY OTHER CRITICAL OPERATING SYSTEM.

WIRING SOLENOID: Fig. 4

WARNING: Failure to wire the solenoid correctly could result in permanent damage to the vehicle's electrical system and/or cause a fire. If any fuse or wire needs to be replaced or extended, they must meet or exceed specifications rating specified in this manual. Any deviation to the electrical specifications is at the installers/users risk. **IMPORTANT:** Disconnect the vehicles battery before beginning any wiring. **IMPORTANT:** The solenoid wire must be connected to the 3-amp inline fuse (included with horn) at the point of the +12-volt connection such as the fuse block, the vehicle's battery or any 12-volt power source which is rated by vehicle's manufacturer capable of handling 3-amps. If either of the solenoid wires need to be lengthened use 18 gauge or heavier wire. The solenoid is a low current device, to operate this product at peak performance make sure all connections are clean of paint, rust and corrosion and firmly secured.

20. Connect one (1) of the solenoid's male 1/4" wire terminals to a positive (+) power source such as the vehicle's (+) battery terminal, alternator, fuse block or etc. **IMPORTANT:** Always use the in-line fuse provided to protect the vehicle. The fuse should not be more than 10" from the power source. (Note: if you need to replace the fuse use the same type, 3-amp.)
21. Connect the solenoid's other 1/4" male terminal to the horn switch. (Horn switch not included).
22. Connect the horn switch's other terminal to ground, any metal body bolt that is clean of paint and rust.
23. Reconnect the vehicle's battery cable, fill air tank, and test horn.

NOTE: Tape all connections and secure all wires. Check for any air leaks using soapy water.

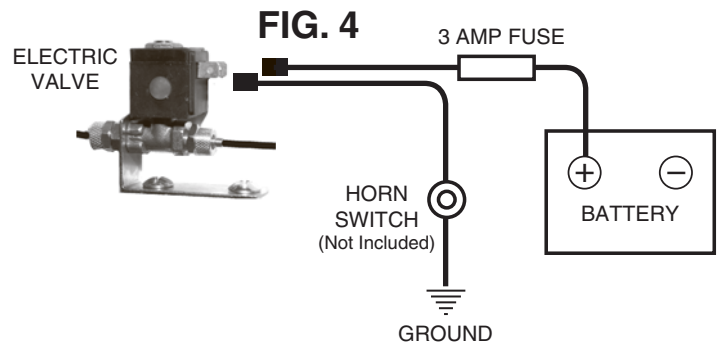
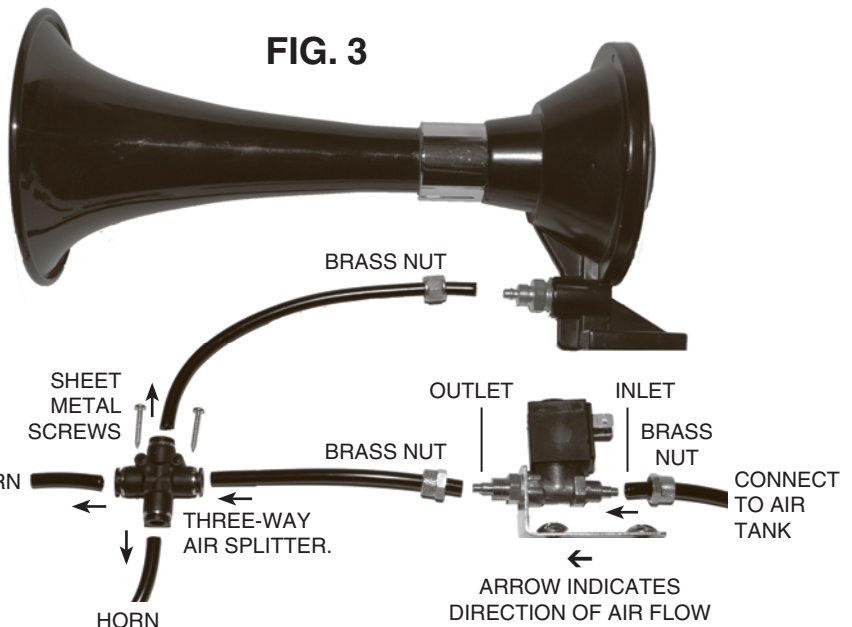

Installation Instructions for Model 860 AIR TANK & COMPRESSOR

Your purchase of an WOLO Air Tank & Compressor is a perfect choice to power your high-pressure air horns, tools and accessories. The Wolo name, with more than thirty years of experience, is your guarantee of a superior horn product.

IMPORTANT: The compressor comes separated from the air storage tank. The installer has the option to attach the compressor to the tank or surface mount to the vehicle, independent of the tank.

COMPRESSOR MOUNTED TO THE TANK (Fig. 1):

1. Place the compressor onto the tanks mounting brackets. Align compressor's rubber vibration bushings with the tanks mounting brackets. Secure the compressor to the tank mounting brackets using the screws and washers provided.
2. The compressor's stainless steel braided hose is connected to the tanks inlet port. Secure the fitting to the tank with a wrench, until fully tight.

IMPORTANT: Do not remove the white Teflon® tape from hose fitting that connects to the tank's inlet port. The Teflon® tape will help prevent air leaks between the fitting and the tank.

COMPRESSOR SURFACE MOUNTED (Fig. 2 & 2A):

3. Locate a convenient location to mount the compressor that will be dry. If the location is the engine compartment make sure the compressor is safe from the heat of the exhaust manifold and try to mount compressor as far to the front of vehicle as possible to provide optimum airflow around compressor.

IMPORTANT! Do not mount on a plastic fender well, or on flexible material.

4. Using the compressor's mounting base as a template, mark the hole locations and drill to size, use a 3/16" drill bit. Secure the compressor to the mounting surface using the hardware provided. (Fig. 2A)

IMPORTANT! When selecting a mounting location for the compressor, make sure that the compressor's braided hose is able to connect to the tank's inlet port. (Fig. 2)

TANK INSTALLATION (Fig. 2B):

5. The mounting location for the tank should be easily reachable so that the tank can be periodically serviced, draining condensation, water from the petcock located on the bottom of the tank.
6. Use the tank's mounting bracket as a template, mark the hole locations and drill to size 15/32". Secure tank with hardware provided.

Fig. 1

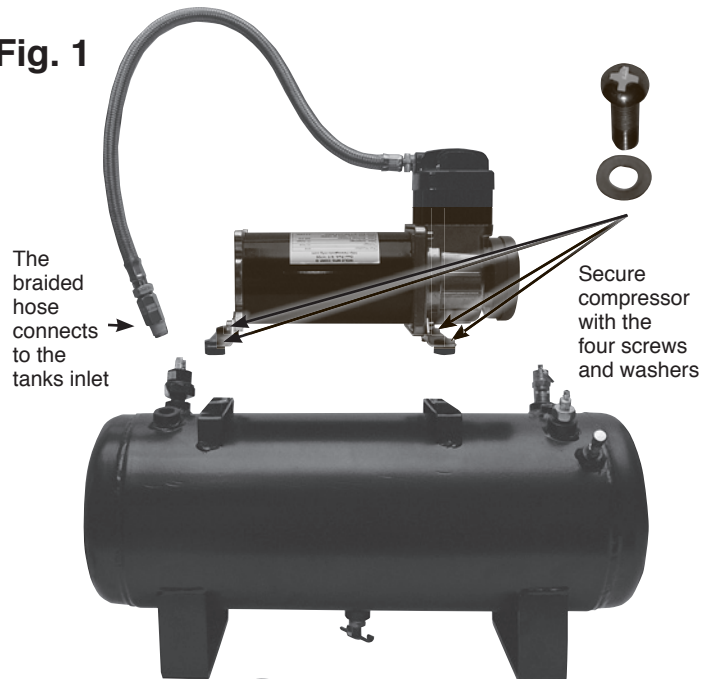

Fig. 2

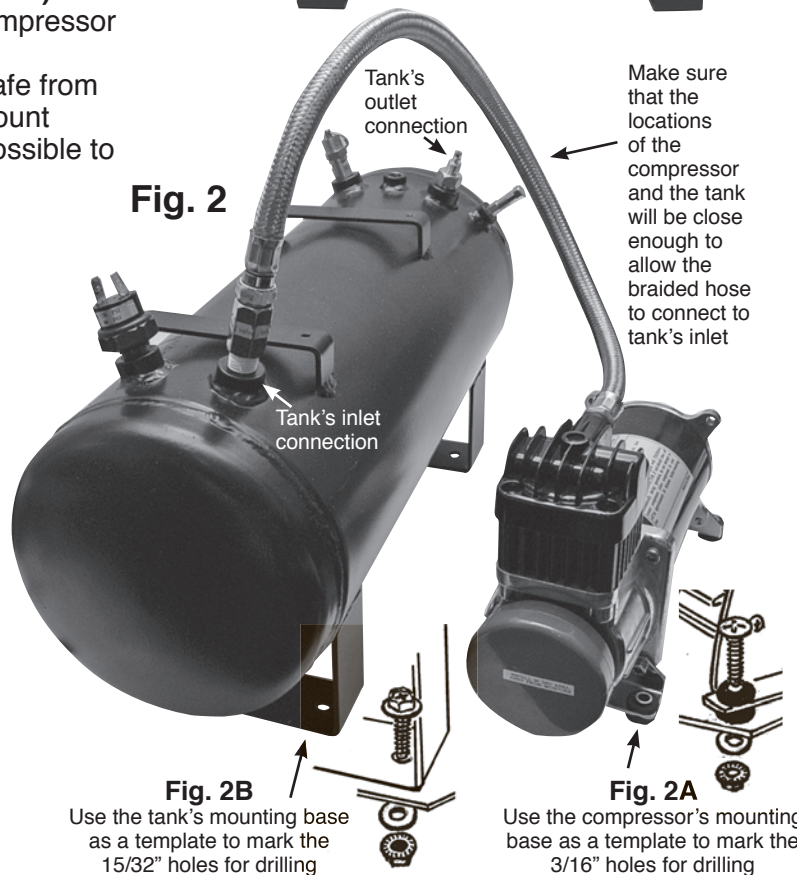

Fig. 2B

Use the tank's mounting base as a template to mark the 15/32" holes for drilling

Fig. 2A

Use the compressor's mounting base as a template to mark the 3/16" holes for drilling

HOSE INSTALLATION (Fig. 3 and Fig. 4):

7. Connect the stainless steel braided hose from the compressor to tank's inlet port. **IMPORTANT:** Do not remove the white Teflon[®] tape from hose fitting that connects to the tank's inlet port. The Teflon[®] tape will help prevent air leaks between the fitting and the tank.
8. Using the high-pressure plastic hose provided, cut to size to be able to connect the tank to inlet fitting of the accessory or valve requiring high-pressure air. Place the brass nut from the tank's outlet fitting onto the high-pressure plastic hose. Push the plastic hose fully onto the outlet fitting, tighten the brass nut onto the outlet fitting. (Fig. 4 and 5)
CAUTION: Do not over tighten the brass nut.
9. The other end of the plastic hose is connected to the accessory or valve requiring high-pressure air.

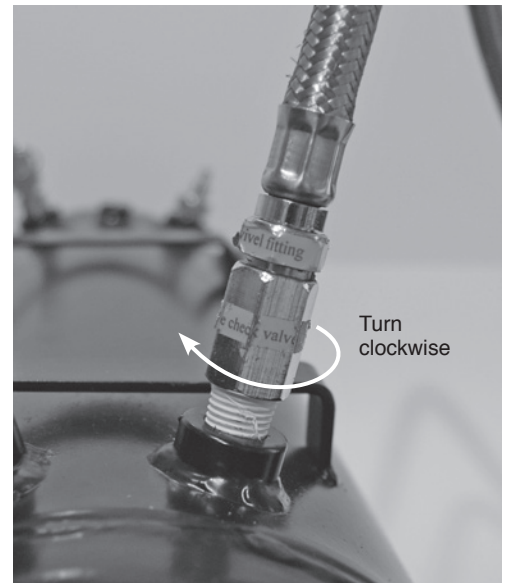
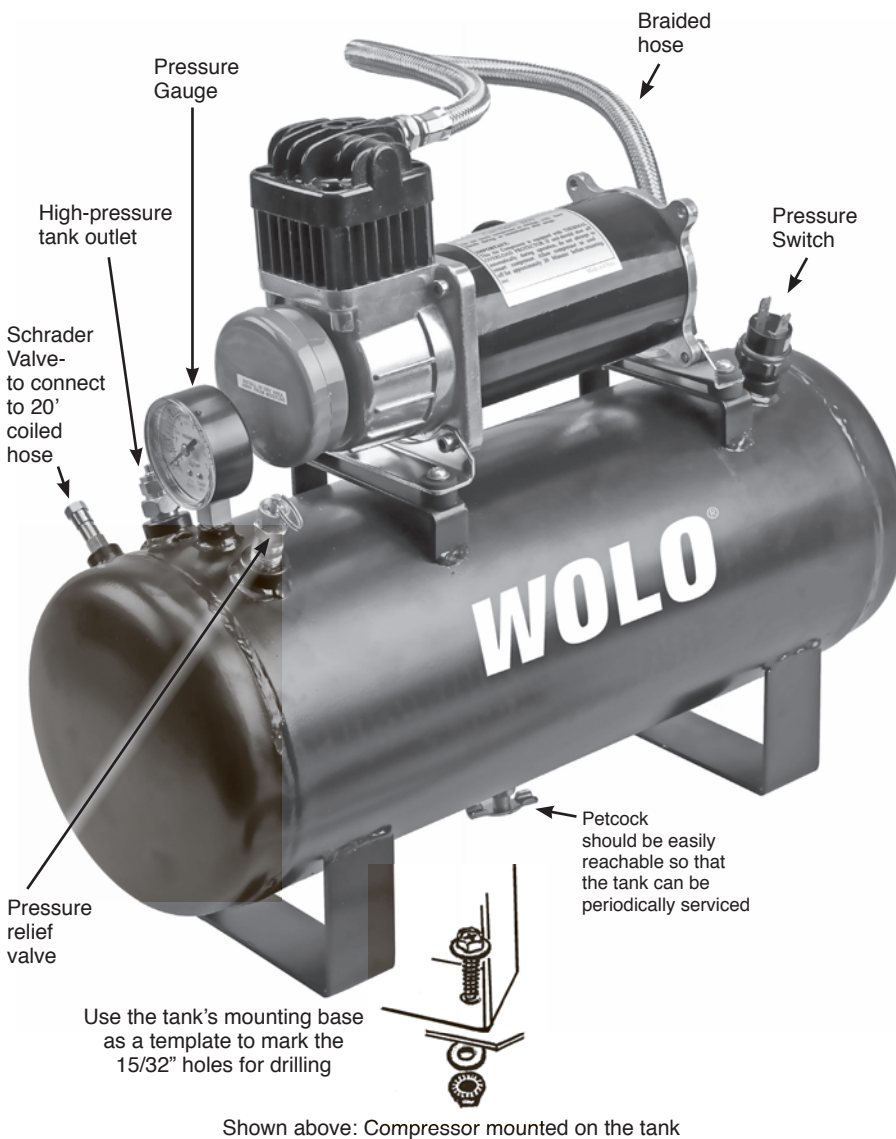

Fig. 3 Connecting the metal braided hose

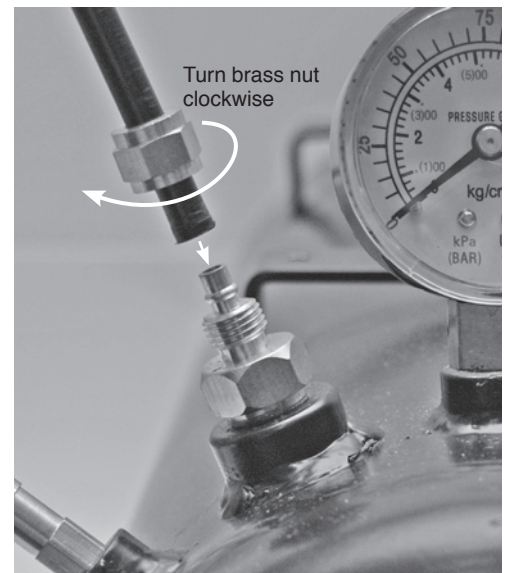

Fig. 4 Connecting the high-pressure plastic hose



Fig. 5 High-pressure plastic hose connected

WIRING COMPRESSOR (Fig. 7 through Fig. 9):

10. The compressor's red wire is connected to a (+) 12-volt power source, using the fuse provided.

IMPORTANT! The fuse must be connected directly to the power source.

IMPORTANT! The red fused wire must be connected to a (+) 12-volt power source controlled by the vehicle's ignition switch. This will protect your compressor from running continuously and being damaged if an air leak develops when the vehicle is not in operation. Suggested connection points are: blower motor, windshield wiper motor or the accessory terminal on the fuse panel. Make sure the connection point has a wire that is as heavy as the compressor's wires and the connection point is capable of handling 25-amps. **CAUTION:** remove the fuse from the fuse holder until installation is complete.

Fig. 7

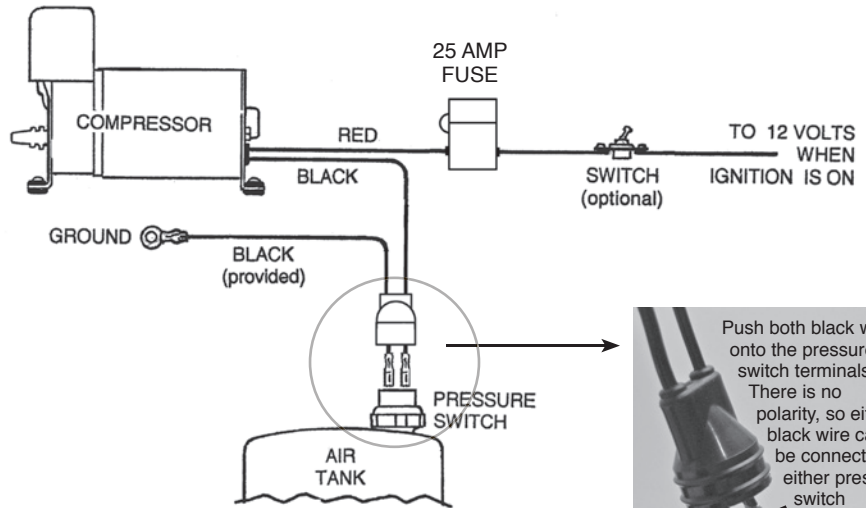

OPTIONAL: A switch can be installed into the compressor's red wire. This will permit the driver to turn-off the system if it is not required. (Fig. 7)

11. The compressor's black wire is connected to a rubber plug. **NOTE:** the rubber plug will have two black wires, both wires will connect to the tank's pressure switch.
- IMPORTANT:** It is recommended that both black wires be pushed forward so that the terminals are extending out of the rubber boot exposing the 1/4" female terminals (Fig. 8).
12. Select one of the black wires with the 1/4" female terminal, connect the terminal to the pressure switch. Repeat the procedure for the other black wire. **NOTE:** There is no polarity, so either black wire can be connected to either pressure switch terminal (Fig. 8).
13. Push the rubber boot onto the pressure switch (Fig. 9).
14. The black wire with the looped terminal is connected to ground; secure the wire's terminal to either the (-) side of vehicle's battery or under any metal body bolt. Make sure that the ground connection is free of rust and paint. **NOTE:** The compressor is now ready to be used. Install the fuse back into the fuse holder and the compressor will automatically start. When the pressure drops below 80 PSI in the tank, the pressure switch will automatically turn on the compressor. When the tank pressure is approximately 120 PSI the compressor will automatically turn off. If the compressor does not shut off after 4 minutes of running time, check all air hose connections for leaks. Use soapy water or bubble solution on each fitting, while the compressor is pumping. Use a thread sealant if leak persists after tightening.

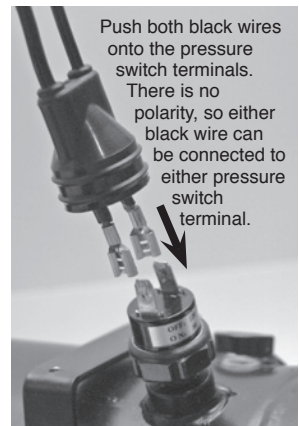

Fig. 8

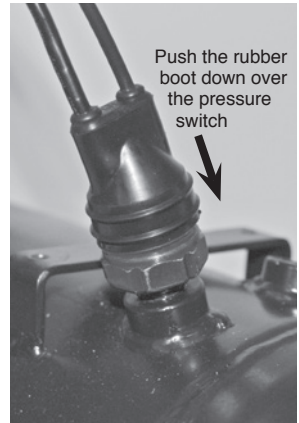

Fig. 9

CAUTION: Do not touch compressor or fittings with bare hands during or immediately after usage, they will be hot.

IMPORTANT! Compressor is equipped with an internal THERMAL OVERLOAD PROTECTOR. If compressor should shut off before the tank has been filled to the pressure switch's turn off pressure, do not attempt to restart compressor. Allow compressor to cool off for approximately 40 minutes before resuming use.

COMPRESSOR SPECIFICATIONS

12-Volt heavy-duty compressor

Current: 22 amps at peak

CFM: 3.5

In-line fuse holder with 25 amp fuse provided

Permanent magnetic motor that is gearless and thermally protection

Oil-less maintenance free design

High performance piston ring

Moisture & dust resistant

Painted aluminum alloy cylinder

Mounting base has rubber vibration bushings

Stainless steel braided hose with in-line check valve

Washable air filter

Size: L 11-1/2 in. x W 3-1/2 in. x H 6-1/2 in.

TANK SPECIFICATIONS

5-Gallon

Welded steel mounting brackets

Petcock water drain

Pressure switch 80 psi. auto-on / 120 psi. off

Safety pressure relief valve rated at 150 psi.

Pressure gauge

Fitting all brass

Size: L 20-1/2 in. x W 8-1/2 in. x H 17-1/2 in. Compressor mount on tank

Size: L 20-1/2 in. x W 8-1/2 in. x H 10-1/2 in. Tank only.