

WindRestrictor®

Wind-deflector designed for the C7 CORVETTE



OFFICIAL
LICENSED PRODUCT

IN THE BOX- 1 WIND DEFLECTOR WITH BRACKETS ATTACHED, 2 ALCOHOL PADS, 2 COTTON GLOVES, 1 CLEANER AND RAG, 1 POWER SUPPLY IF LIGHTING WAS ORDERED.

Step-1 Clean the two insert panels with the alcohol pads provided in the box. Make sure the surface is dry before proceeding.

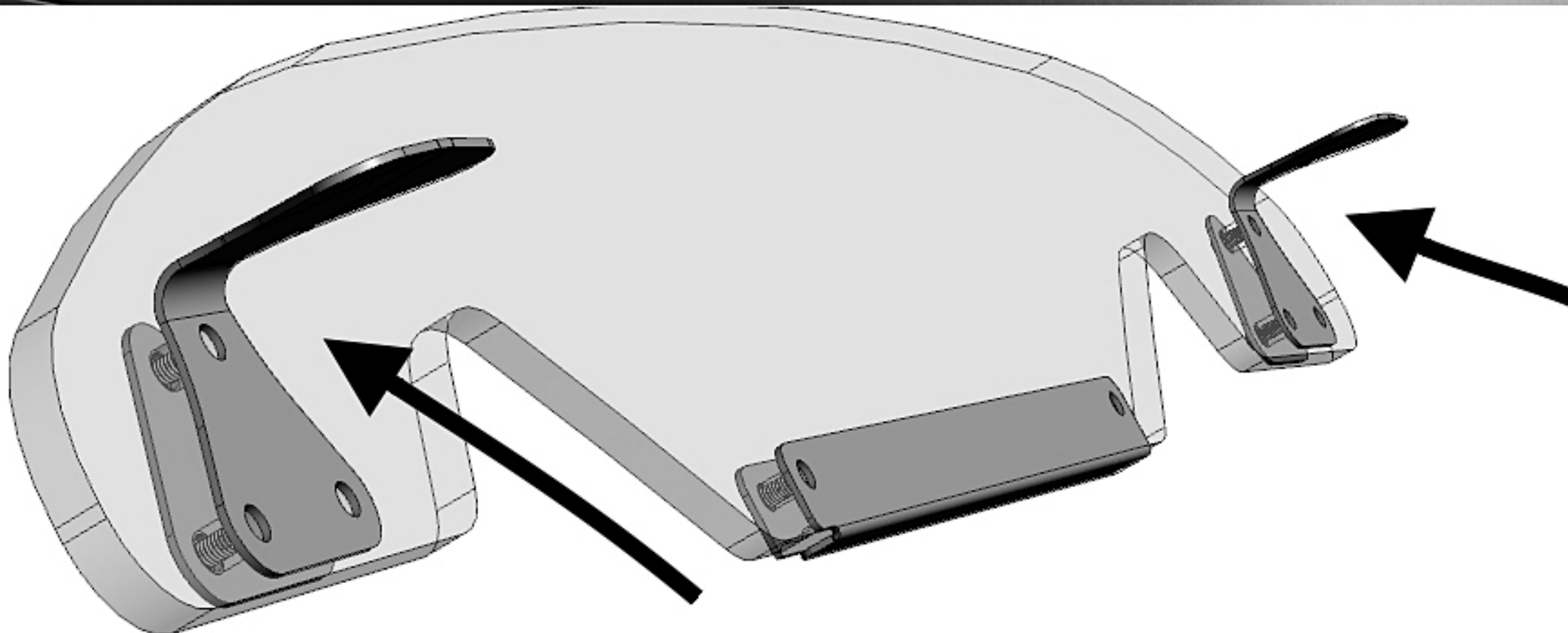
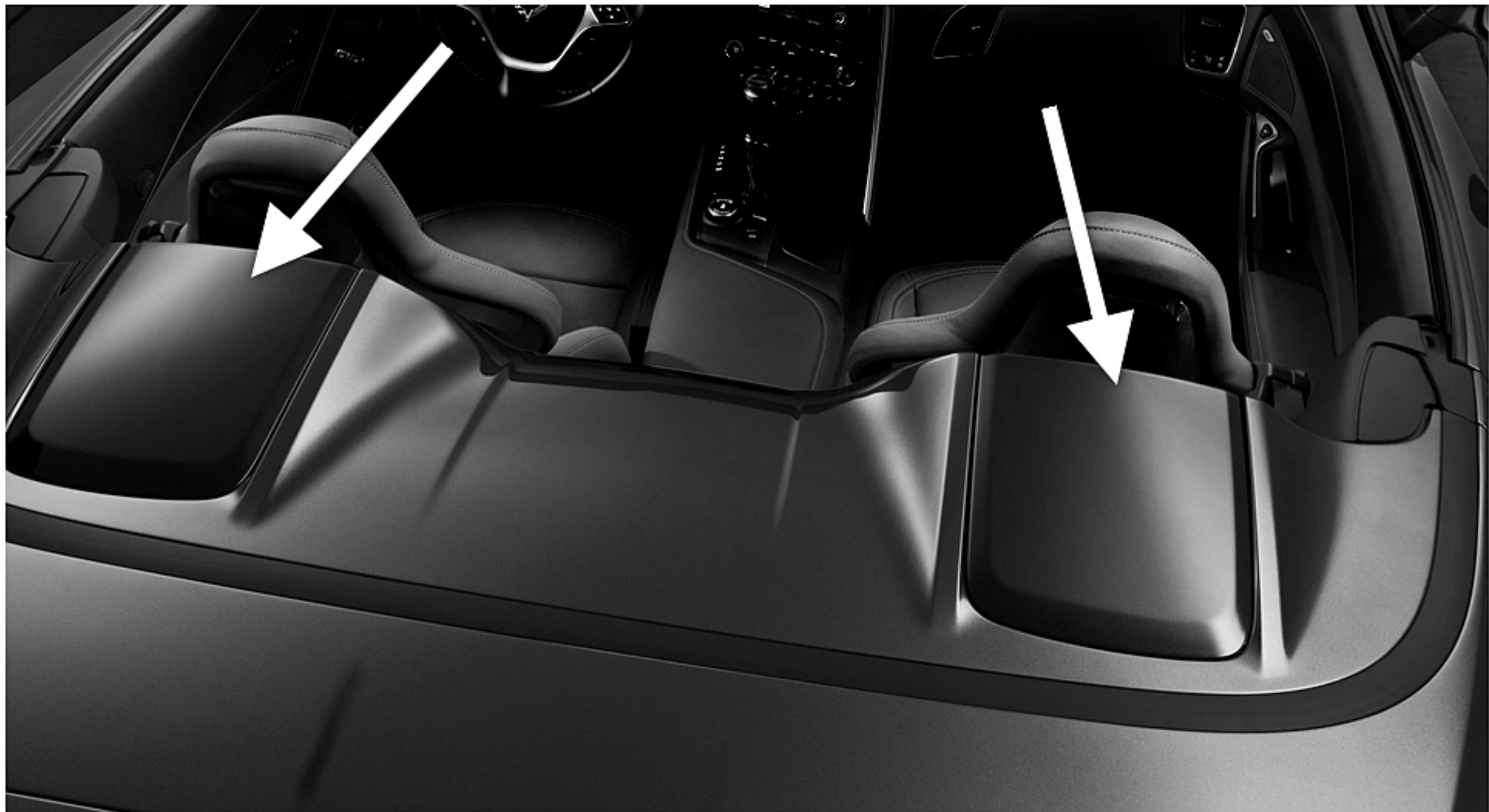

Step-2 Align and center the deflector on vehicle prior to removing protective covering of the bracket tape. Mark the outside edge of brackets with painter's tape to use as a guide once product is centered. Remove covering from bracket tape.

Step-3 Use a heat gun or hair dryer to heat up the adhesive pads on brackets five seconds each. Do not overheat or damage pads, simply warm.

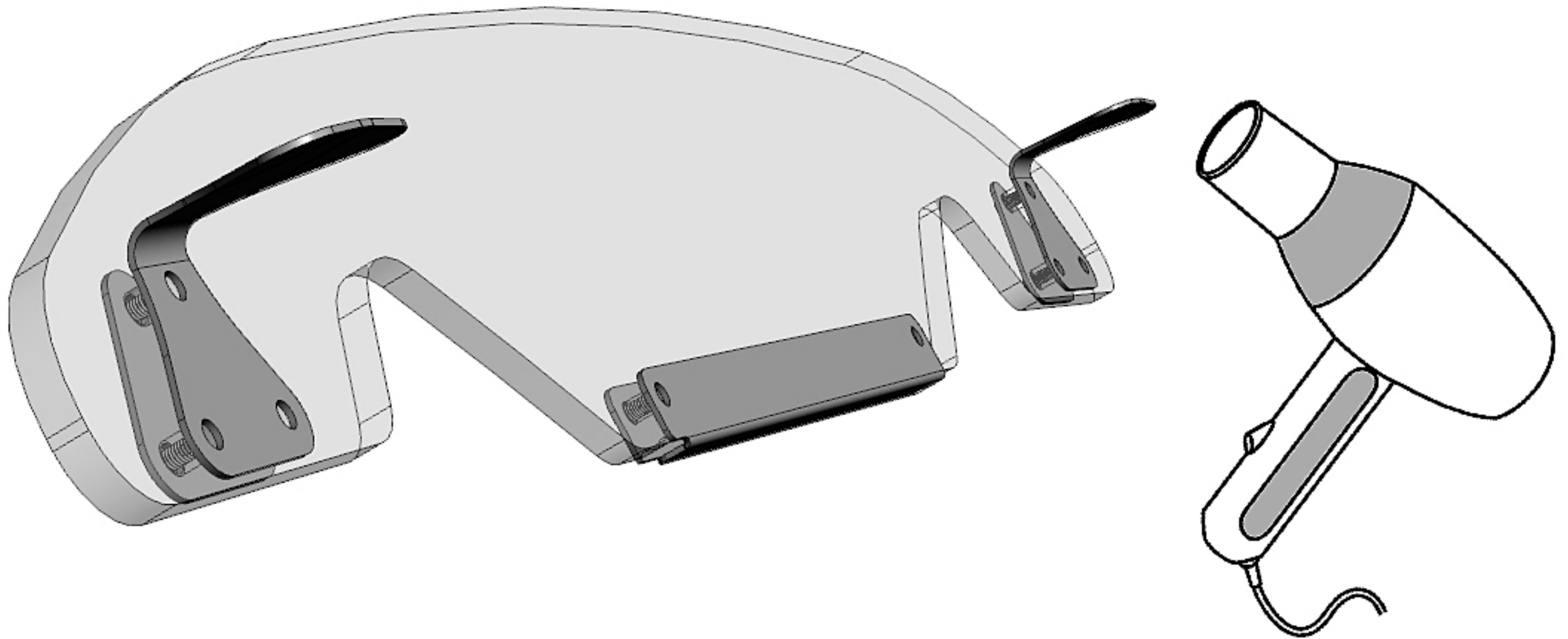

Step-4 Center the product between the painter's tape on panel. The two screws on bar (A) should perfectly line up with the two indentions on the tonneau cover (B). After confirming product is centered apply **FIRM** pressure simultaneously to front and top side of bracket for 20 seconds. If you have the illuminated version proceed to step 5. If you do not have the lighted version you are now finished!

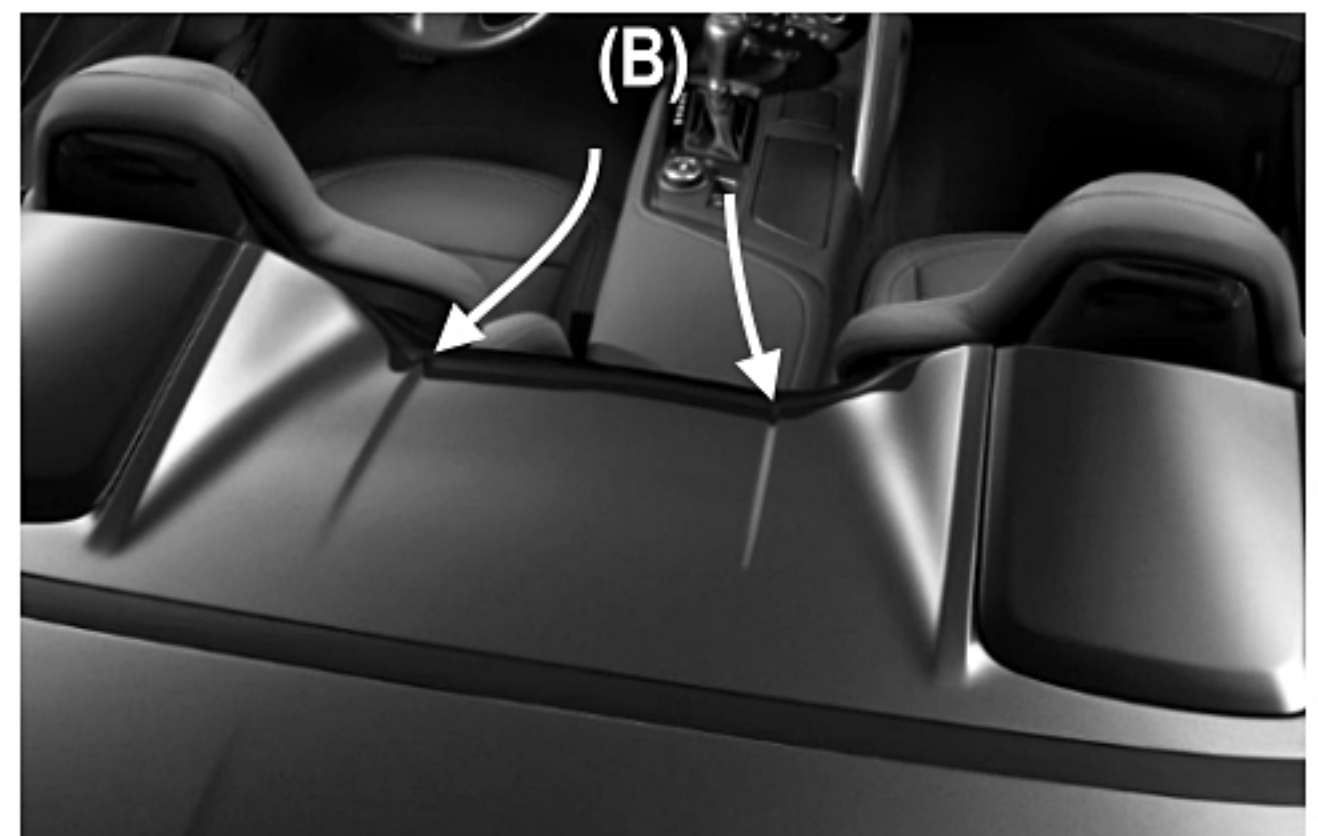
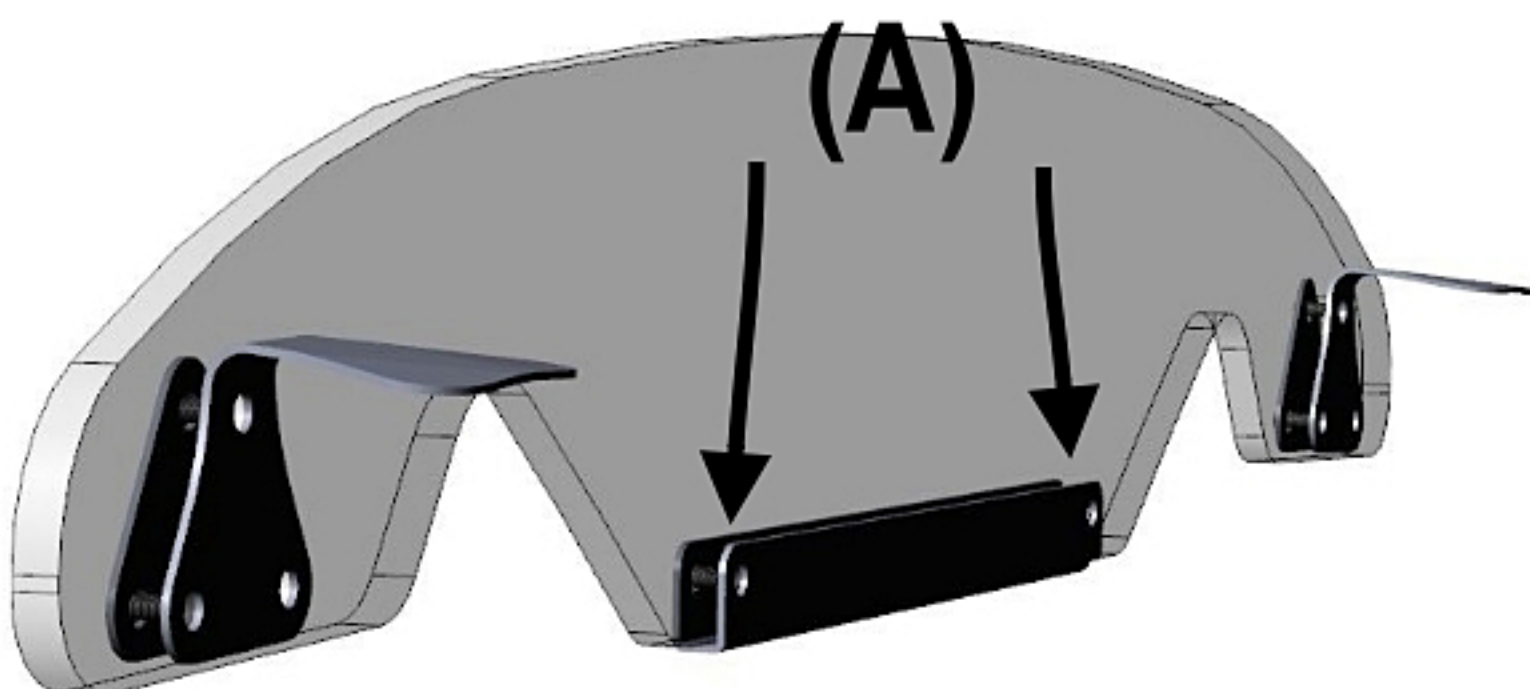

Step-5 Attach the 12V power supply to the cord from wind blocker. Peel off the adhesive cover that is on the back of power supply. Mount the box under the lid as shown below. be sure the adhesive side goes towards the rear of vehicle. There should be a flat area just above where the speaker panel meets the tonneau cover. The power supply should be mounted as far up as possible, so that it is out of the way of the panel when closing and opening the top. It may be helpful to refer to our installation video on this step.



That's it! You are now ready to use your new WINDRESTRICTOR® brand wind blocker!

ABOUT THE POWER SUPPLY

The power supply will hold a full 35 hour charge. If used at the average rate per night it should last around 6 weeks before needing to recharge. When you need to recharge, first unsnap it from the panel and unplug from the wind blocker. Then using the plug that came with it, plug it in the wall for around 4-5 hours. When you are charging it make sure the switch is in the ON position or it will not recharge. Do not be concerned if the red light does not turn green. Some of the packs do not have that feature even though it's mentioned on the box.