

WILWOOD ENGINEERING

BRAKE PEDAL AND BALANCE BAR INSTRUCTION GUIDE

**DISC BRAKES SHOULD ONLY BE INSTALLED BY SOMEONE
EXPERIENCED AND COMPETENT IN THE INSTALLATION AND
MAINTENANCE OF DISC BRAKES
READ ALL WARNINGS**

WARNING

IT IS THE RESPONSIBILITY OF THE PERSON INSTALLING ANY BRAKE COMPONENT OR KIT TO DETERMINE THE SUITABILITY OF THE COMPONENT OR KIT FOR THAT PARTICULAR APPLICATION. IF YOU ARE NOT SURE HOW TO SAFELY USE THIS BRAKE COMPONENT OR KIT, YOU SHOULD NOT INSTALL OR USE IT. DO NOT ASSUME ANYTHING. IMPROPERLY INSTALLED OR MAINTAINED BRAKES ARE DANGEROUS. IF YOU ARE NOT SURE, GET HELP OR RETURN THE PRODUCT. **YOU**, OR THE PERSON WHO DOES THE INSTALLATION MUST KNOW HOW TO PROPERLY USE THIS PRODUCT. IT IS NOT POSSIBLE OVER THE PHONE TO UNDERSTAND OR FORESEE ALL THE ISSUES THAT MIGHT ARISE IN YOUR INSTALLATION.

RACING EQUIPMENT AND BRAKES MUST BE MAINTAINED AND SHOULD BE CHECKED REGULARLY FOR FATIGUE, DAMAGE, AND WEAR.



WARNING

**DO NOT OPERATE ANY VEHICLE ON UNTESTED BRAKES!
SEE MINIMUM TEST PROCEDURE WITHIN**

ALWAYS UTILIZE SAFETY RESTRAINT SYSTEMS AND ALL OTHER AVAILABLE SAFETY EQUIPMENT WHILE OPERATING THE VEHICLE

IMPORTANT • READ THE DISCLAIMER OF WARRANTY INCLUDED IN THE KIT

NOTE: Some cleaners may stain or remove the finish on brake system components. Test the cleaner on a hidden portion of the component before general use.

Photographic Tip

Important and highly recommended: Take photos of brake system before disassembly and during the disassembly process. In the event, trouble-shooting photos can be life savers. Many vehicles have undocumented variations, photos will make it much simpler for Wilwood to assist you if you have a problem.

WILWOOD PEDAL ASSEMBLY AND BALANCE BAR

Wilwood pedal assemblies and integrated balance bars have been designed specifically for racing applications. Properly set-up, this assembly will allow for the precise adjustment of front-to-rear brake bias adjustment.

The advantages of an adjustable balance bar and dual master cylinders are:

1. Brake proportioning can be adjusted by use of different size master cylinder bores for front and rear brakes.
2. Front to rear brake balance can be fine tuned by adjusting the balance bar.
3. With two independent hydraulic systems, should one master cylinder fail, the other system may remain functional.

Master cylinder selection should correspond to your caliper piston displacement. Your Wilwood dealer, or Wilwood can recommend specific master cylinders for your Wilwood calipers. Table 1 lists recommended master cylinder sizes for Wilwood calipers.

Table 1. Caliper piston displacement - master cylinder size

CALIPER TYPE	CALIPERS PER M.C.	PISTON DIAMETER	NO. OF PISTONS/CALIPER	RECOMMENDED M.C. SIZE
GT / GT 6000	2	1.88" / 1.75"	4	3/4" - 7/8"
GN	2	1.75" / 1.38" / 1.38"	6	7/8" - 1"
SL / DL	2	1.75"	4	7/8" - 3/4"
SL / DL	2	1.38"	4	7/8" - 3/4"
SL	2	1.12"	4	7/8" - 3/4"
DLS	2	1.75"	2	7/8" - 3/4"
GM	2	2.75"	1	7/8" - 1"
GM	2	2.38"	1	7/8" - 1"

Brake pedals should be mounted securely. Clutch pedal, brake pedal and master cylinder placement should be considered when mounting the pedal assembly. Note that it is always desirable to keep the master cylinder reservoir level higher than the horizontal plane of the calipers to prevent excessive fluid drain back which can result in double pumping of the pedal. If this is not possible, a two pound residual pressure valve should be plumbed into the brake line at the exit of the master cylinder to prevent fluid drain back (do not confuse the two pound valve with the ten pound version; the ten pound valve is for use with drum brakes only!).

Brake pedals should be free to return when no pressure is being applied, allowing the master cylinder pushrod to return to its undepressed position. In some cases, the master cylinder spring (internal) may not be strong enough to fully return the pushrod; in this case an additional pedal return spring can be used. There are two important items for consideration:

1. The brake pedal should have an adjustable return stop on it when a strong pedal return spring is used. This prevents the master cylinder from excessively banging the snap ring stop inside the master cylinder bore (visible under the rubber boot). Adjust the stop so the pedal stops returning at the point when the master cylinder piston retracts against the snap ring, Figure 1.
2. The master cylinder piston must fully retract. If the master cylinder piston is not allowed to fully retract when the brake pedal is not applied, the primary inside seal will not return past the small pressure relief hole (visible within the master cylinder reservoir on some master cylinders). This can cause excessive residual line pressure and contribute to brake drag and an overheating condition, see Figure 1, Detail "A".

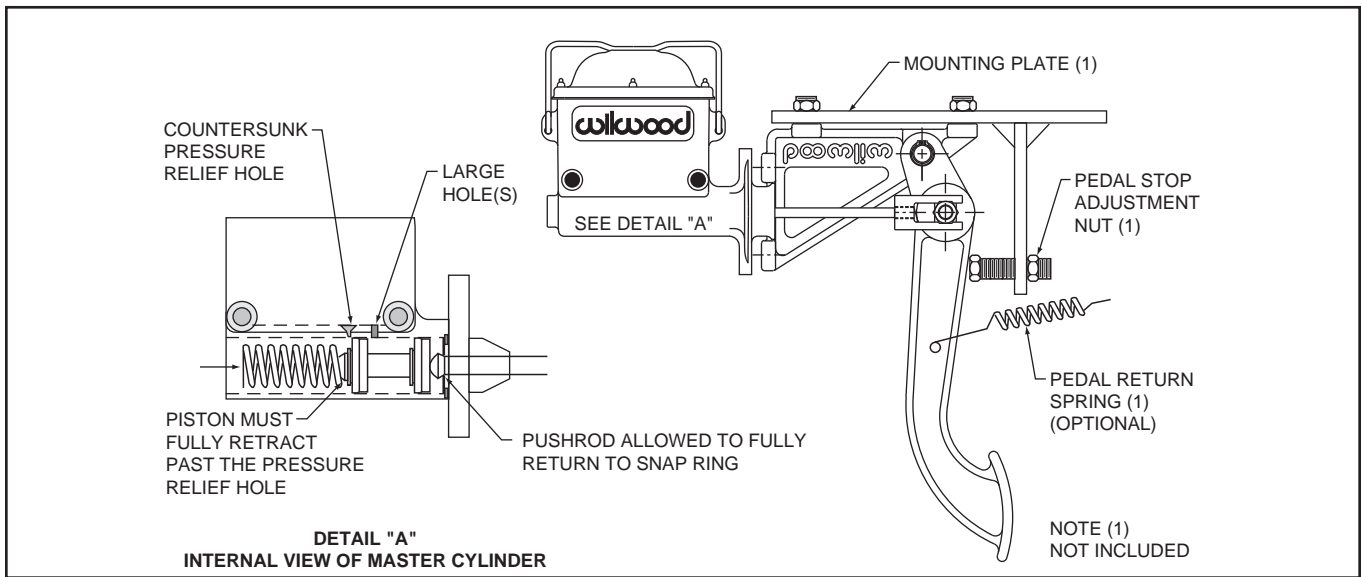

Figure 1. Master cylinder pedal stop and return hole position

BALANCE BAR ADJUSTMENT

The balance bar is an adjustable lever (usually a threaded rod), that pivots on a spherical bearing and uses two separate master cylinders for the front and rear brakes. Most balance bars are part of a pedal assembly that also provides a mounting for the master cylinders. When the balance bar is centered, it pushes equally on both master cylinders creating equal pressure, given that the master cylinders are the same size bore. When adjusted as far as possible toward one master cylinder it will push approximately twice as hard on that cylinder as the other, Figure 2.

Thread the master cylinder pushrods through their respective clevises to obtain the desired position. Threading one pushrod into its respective clevis means threading the other one out the same amount. Sometimes this will lead to a “cocked” balance bar when the pedal is in the relaxed position, see Figure 2, “no pedal effort”. This is perfectly acceptable as long as each master cylinder pushrod is completely free of pressure when the pedal is relaxed.

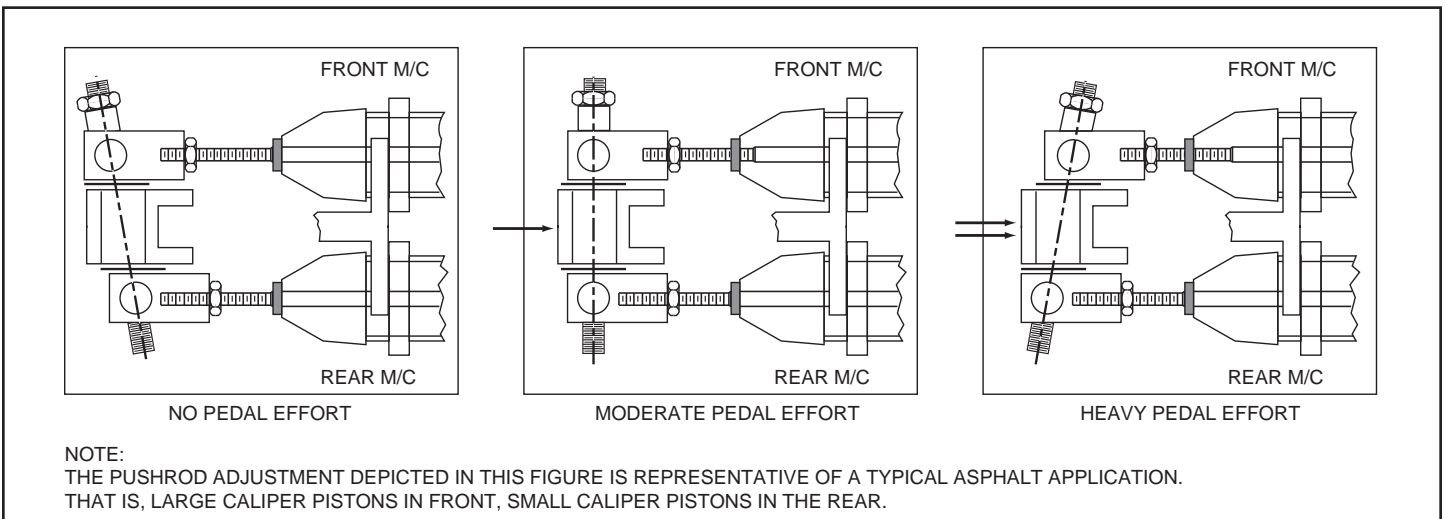

Figure 2. Balance bar lever adjustment

Notes:

To obtain maximum performance from your brake system you should utilize Wilwoods quick check gauge, P/N 260-0966. This gauge allows for quick brake line pressure checks from 0 - 1,500 psi for assisting brake bias set-up.

A flexible hose or cable connecting the balance bar (threaded rod) to an accessible knob or crank (similar to a drill auger) is a popular way of adjusting brake bias to accommodate changes in track conditions and vehicle handling.

It is important that the operation of the balance bar functions without interference by over adjustment. This can occur when a clevis jams against the side of the pedal or the lever (bolt) hits the pedal bore during any point of pedal travel, Figure 3.

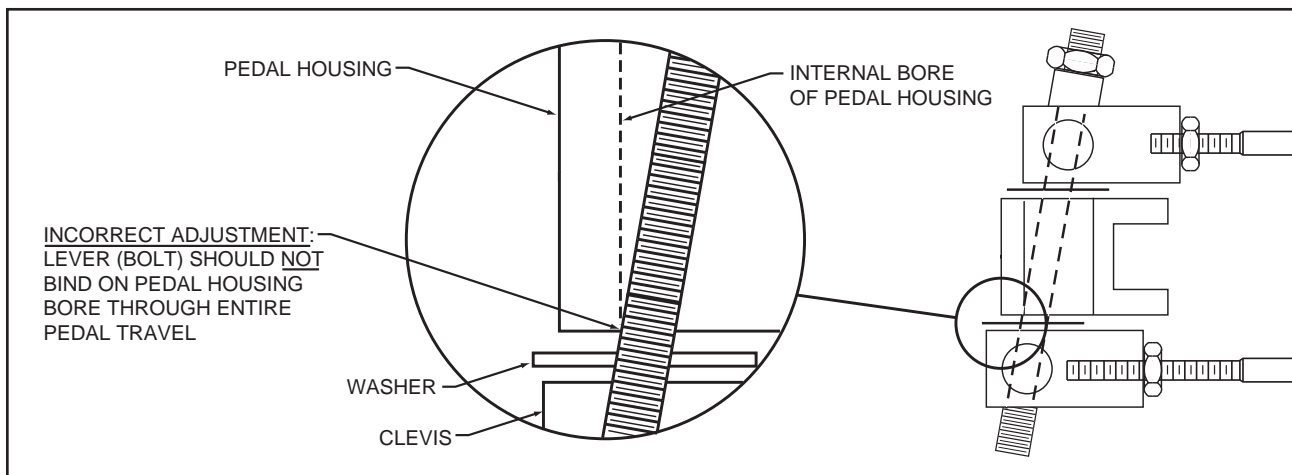

Figure 3. Balance bar lever interference

Lever movement should be unimpeded throughout pedal travel. In the neutral position, clevis's should have between .20" - .25" total clearance between the side of the pedal. The large washers between the pedal and clevis should remain loose. Make sure that the master cylinder pushrods remain true in relationship to the cylinder during entire pedal travel; pushrods should not be pushing master cylinder pistons at an angle. See Figure 4. NOTE: In its non-depressed position, the pedal and balance bar should allow the pushrod of the master cylinders to fully return. This can be checked by feeling pushrods for very *slight* movement, not loose movement. Master cylinder pistons should be against the retaining snap ring (under boot).

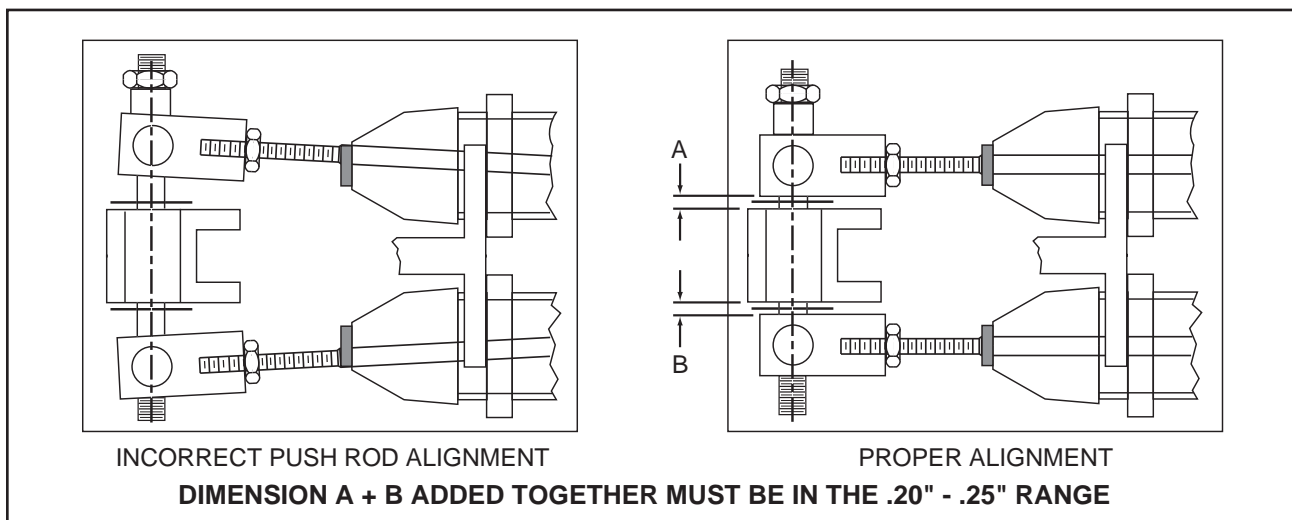

Figure 4. Example of pushrod alignment

Brake balancing can also be affected by changes made in the following:

1. Master cylinder size.
2. Caliper piston size.
3. Use of a proportioning valve.

A full understanding of the entire brake system is important to maximize brake system performance. Use of a balance bar pedal assembly can enhance a brake system with the proper installation and adjustment.

Should you have further questions, consult your authorized Wilwood dealer, or Wilwood Engineering.

Brake Testing and Pad Bedding

WARNING • DO NOT DRIVE ON UNTESTED BRAKES BRAKES MUST BE TESTED AFTER INSTALLATION OR MAINTENANCE MINIMUM TEST PROCEDURE

- Make sure pedal is firm: Hold firm pressure on pedal for several minutes, it should remain in position without sinking. If pedal sinks toward floor, check system for fluid leaks. DO NOT drive vehicle if pedal does not stay firm or can be pushed to the floor with normal pressure.
- At very low speed (2-5 mph) apply brakes hard several times while turning steering from full left to full right, repeat several times. Remove the wheels and check that components are not touching, rubbing, or leaking.
- Carefully examine all brake components, brake lines, and fittings for leaks and interference.
- Make sure there is no interference with wheels or suspension components.
- Drive vehicle at low speed (15-20 mph) making moderate and hard stops. Brakes should feel normal and positive. Again check for leaks and interference.
- Always test vehicle in a safe place where there is no danger to (or from) other people or vehicles.
- Always wear seat belts and make use of all safety equipment.

Pad and Rotor Bedding

BEDDING STEPS FOR NEW PADS AND ROTORS – ALL COMPOUNDS

Once the brake system has been tested and determined safe to operate the vehicle, follow these steps for the bedding of all new pad materials and rotors. These procedures should only be performed on a race track, or other safe location where you can safely and legally obtain speeds up to 65 MPH, while also being able to rapidly decelerate.

- Begin with a series of light decelerations to gradually build some heat in the brakes. Use an on-and-off the pedal technique by applying the brakes for 3-5 seconds, and then allow them to fully release for a period roughly twice as long as the deceleration cycle. If you use a 5 count during the deceleration interval, use a 10 count during the release to allow the heat to sink into the pads and rotors.
- After several cycles of light stops to begin warming the brakes, proceed with a series of medium to firm deceleration stops to continue raising the temperature level in the brakes.
- Finish the bedding cycle with a series of 8-10 hard decelerations from 55-65 MPH down to 25 MPH while allowing a proportionate release and heat-sinking interval between each stop. The pads should now be providing positive and consistent response.
- If any amount of brake fade is observed during the bed-in cycle, immediately begin the cool down cycle.
- Drive at a moderate cruising speed, with the least amount of brake contact possible, until most of the heat has dissipated from the brakes. Avoid sitting stopped with the brake pedal depressed to hold the car in place during this time. Park the vehicle and allow the brakes to cool to ambient air temperature.

COMPETITION VEHICLES

- If your race car is equipped with brake cooling ducts, blocking them will allow the pads and rotors to warm up quicker and speed up the bedding process.
- Temperature indicating paint on the rotor and pad edges can provide valuable data regarding observed temperatures during the bedding process and subsequent on-track sessions. This information can be highly beneficial when evaluating pad compounds and cooling efficiencies.

Pad and Rotor Bedding (Continued)

POST-BEDDING INSPECTION – ALL VEHICLES

- After the bedding cycle, the rotors should exhibit a uniformly burnished finish across the entire contact face. Any surface irregularities that appear as smearing or splotching on the rotor faces can be an indication that the brakes were brought up to temperature too quickly during the bedding cycle. If the smear doesn't blend away after the next run-in cycle, or if chatter under braking results, sanding or resurfacing the rotors will be required to restore a uniform surface for pad contact.

PRE-RACE WARM UP

- Always make every effort to get heat into the brakes prior to each event. Use an on-and-off the pedal practice to warm the brakes during the trip to the staging zone, during parade laps before the flag drops, and every other opportunity in an effort to build heat in the pads and rotors. This will help to ensure best consistency, performance, and durability from your brakes.

DYNO BEDDED COMPETITION PADS AND ROTORS

- Getting track time for a proper pad and rotor bedding session can be difficult. Wilwood offers factory dyno-bedded pads and rotors on many of our popular competition pads and **Spec 37** GT series rotors. Dyno-bedded parts are ready to race on their first warm up cycle. This can save valuable time and effort when on-track time is either too valuable or not available at all, Dyno-bedding assures that your pads and rotors have been properly run-in and are ready to go. Contact your dealer or the factory for more information on Wilwood Dyno-Bedding services.

NOTE:

NEVER allow the contact surfaces of the pads or rotors to be contaminated with brake fluid. Always use a catch bottle with a hose to prevent fluid spill during all brake bleeding procedures.