

**DISC BRAKES**  
**wilwood**

# INLINE DUAL CYLINDER CUTTING BRAKE ASSEMBLY

*WILWOOD'S Inline Dual Cylinder Cutting Brake Assembly utilizes a single inlet, twin outlet flow-through master cylinder to simplify plumbing of the existing calipers and delivers precise steering brake control for all types of off-road competition vehicles.*



## **BRAKE FEATURES**

- All-aluminum design with reduced weight over steel lever models
- High-leverage, forged aluminum lever arm with full-length ergonomic grip
- Full and balanced function of both calipers when handle is neutral
- Easy installation of the one-piece body with integral mounting
- 3/4" bore cylinders deliver instant high pressure with minimal effort
- Durable gloss black e-coat finish resists weathering and oxidation



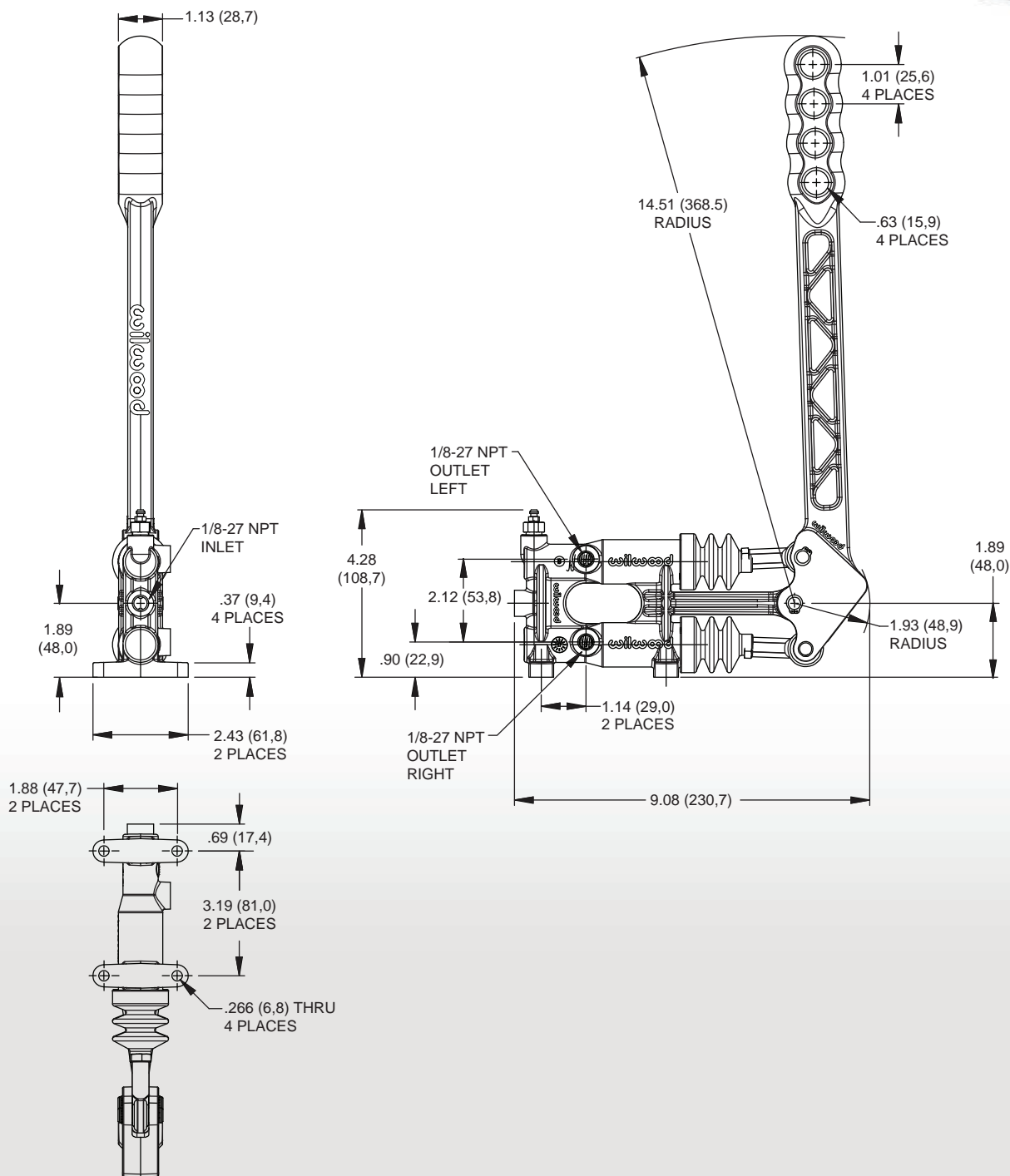

Inline Dual Cylinder Cutting Brake Assembly, Physical Characteristics

## ORDERING INFORMATION: Inline Dual Master Cylinder Cutting Brake Assembly

PART NUMBER	DESCRIPTION	BORE SIZE
340-14744	Inline Dual Master Cylinder Cutting Brake Assembly, 11.00:1 Ratio	3/4"