



MITSUBISHI ECLIPSE GENERATION II DYNAPRO BIG BRAKE FRONT HAT KIT

Models Covered:

Mitsubishi Eclipse Generation II

All 1995-99 2WD, AWD

Kit Features:

- Full Bolt-On installation
- Compatible with OE master cylinder output and ABS
- Requires 16" or larger wheels with minimum internal clearances diagramed on page 2

Component Features:

DynaPro Four Piston Radial Mount Calipers

- Rigid FEA designed billet body provides maximum clamping efficiency and unyielding pedal response by eliminating fluid volume displacement loss from structural deflection at the high output pressures generated by power brake master cylinders.
- Four piston design generates high clamping force with balanced pad loading.
- Quick Clip pad retainers and dust booted pistons allow fast and easy pad service without caliper removal.
- Spring loaded stainless steel SRS bridge plates reduce noise by damping engagement harmonics and stopping pad rattle. Bridge wear from gouging at the pad trailing edge is also eliminated.
- Internal fluid passages prevent all potential problems associated with external fluid transfer tubes.
- Four corner bleed screws accommodate effective gas evacuation regardless of mounting position.
- Radial mounting provides solid attachment with two planes of adjustment for precise alignment and simplified caliper service in the field.

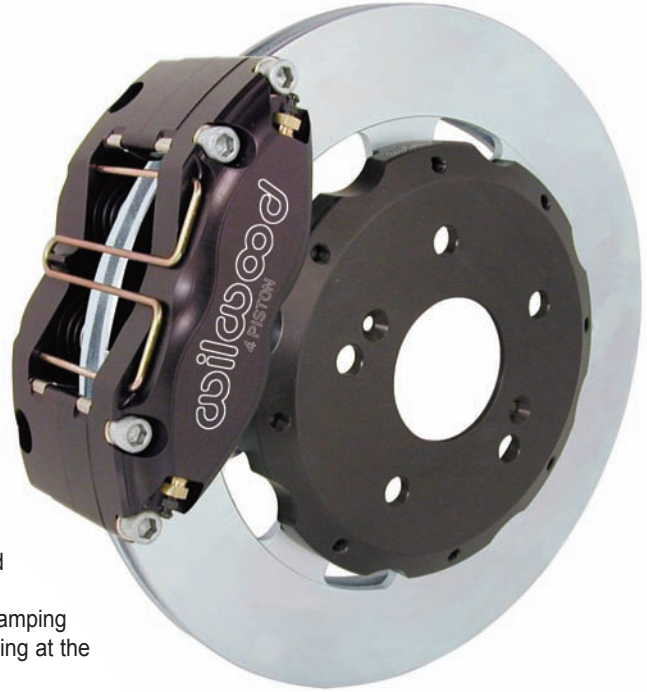

Mitsubishi Big Brake Front
Kit with HP Rotor

SRP or HP Series 12.19" Diameter Rotors

- Increased diameter multiplies stopping leverage over OE diameter rotors.
- 32 vane vented iron design provides high cooling efficiency.
- SRP Series rotors are e-coated to resist corrosion and feature an engineered directional drill and slot pattern for an aggressive high tech appearance inside the wheel. The holes and slots enhance pad performance by reducing pad glazing and dispersing the gasses and some of heat generated during braking.
- HP Series full surface rotors are precision machined at less than .001" for total parallelism, flatness, and run-out to provide true running with reduced knock-back and positive pedal response. This non-drilled version carries additional mass for increased thermal stability in sustained heat competition.

Aluminum Rotor Mounting Hats

- Premium grade alloy aluminum hats are lightweight and provide sturdy mounting of the vented iron rotors on the OE hub assembly
- High luster black anodized finish resists corrosion and enhances the custom appearance inside the wheel

"Smart Pads" with Noise Suppression Shims

- 7816 type BP-10 brake pads provide fast response and high fade resistance with the lowest noise and dust levels available from a performance pad compound
- Viscoelastic multi-layered noise suppression shims provide additional damping of harmonic or resonant vibrations that generate pad squeal

Mounting Hardware and Plumbing

- Machined billet radial mount brackets with all necessary high strength fasteners, washers, and alignment shims are included with each kit.
- Optional flex line kits include stainless steel reinforced hoses with machine crimped ends and the fittings necessary to connect the calipers to the OE brake line fitting at the chassis. Flex line kits must be ordered separately.

Please check the diagram on the back of this page for minimum inside wheel clearance requirements

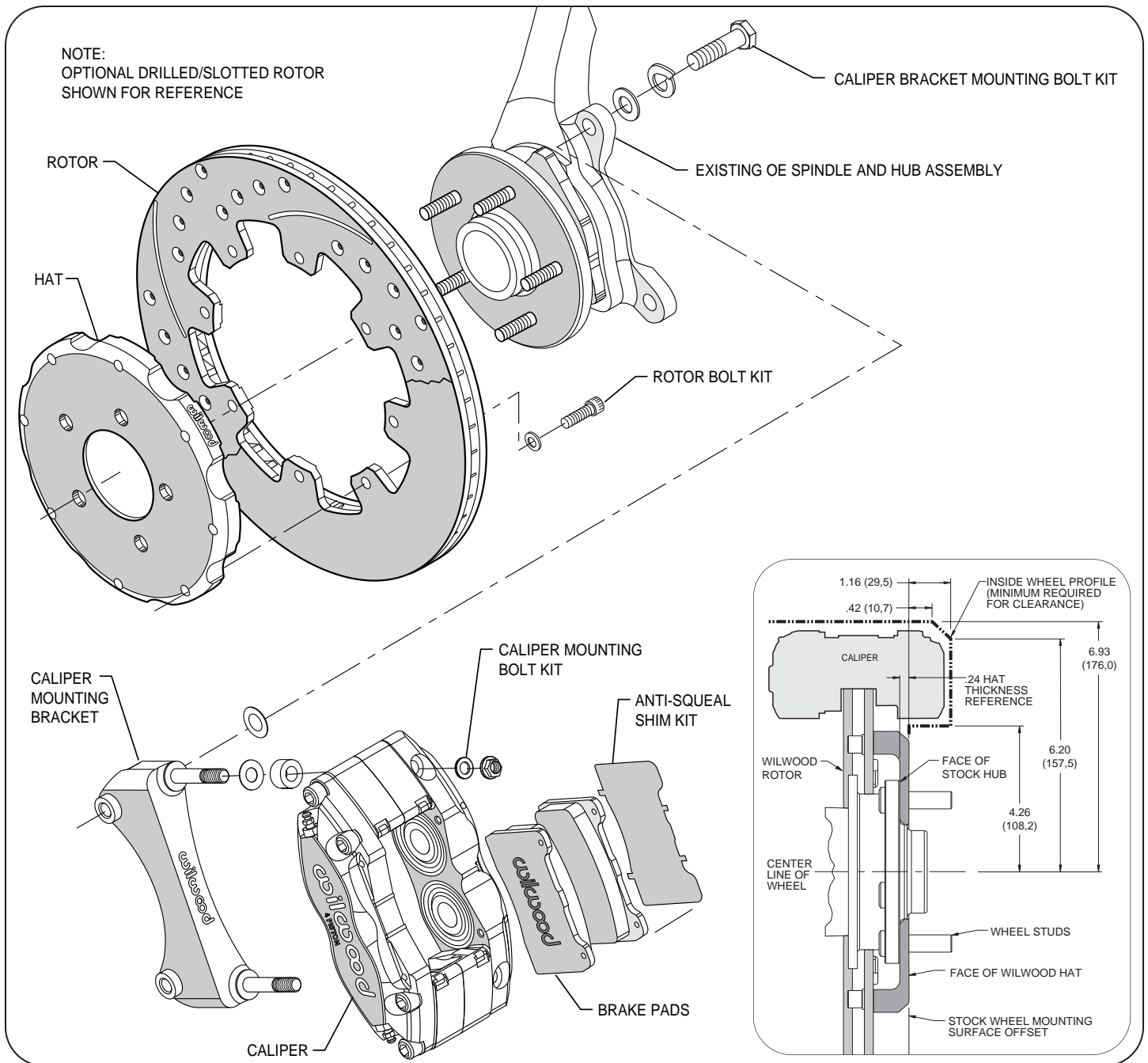

Typical Installation Diagram, Major Components Identified. Minimum Wheel Fit Dimensions Shown Inset

ORDERING INFORMATION: BRAKE AND FLEX LINE KITS:

<u>MAKE / MODEL</u>	<u>YEAR</u>	<u>HP ROTOR KIT</u>	<u>KIT PART NUMBERS</u>	<u>FLEX LINE KITS</u>
			<u>SRP ROTOR KIT</u>	
Mitsubishi Eclipse Gen II	1995-99	140-8292	140-8292-D	220-8293

ORDERING INFORMATION: USER SERVICEABLE COMPONENTS, PART NUMBER:

<u>KIT NUMBER</u>	<u>CALIPER</u>	<u>PAD SET</u>	<u>ROTOR</u>	<u>HAT</u>	<u>ROTOR BOLT KIT</u>	<u>MOUNT BRACKET</u>	<u>MOUNTING BOLT KIT</u>	<u>ANTI-SQUEAL SHIM KIT</u>
140-8292	120-7378	150-8946K	160-5843	170-8320	230-8390	250-8322	230-8391	300-8259
140-8292-D	120-7378	150-8946K	160-7103/04	170-8320	230-8390	250-8322	230-8391	300-8259