



# FRONT DYNALITE BIG BRAKE KIT

## Kit Features:

Get track ready performance and high-tech style with these Dynalite Big Brake kits from Wilwood. These competition brake kits are loaded with cutting edge disc brake technology, and Wilwood's 25 year tradition of building championship brake systems. They are a perfect performance match and just the right look when upgrading your wheels, tires, or suspension handling equipment.

**Billet Dynalite Calipers** This incredibly efficient structural design was developed using advanced solid modeling and stress simulation technology. Weighing in at only 2.7 lbs, the Billet Dynalite delivers powerful clamping force without body deflection and is the industry's lightest four piston racing caliper. Four large diameter 1.75" stainless steel pistons generate an awesome 4.8 line pressure to clamp force multiplier, are corrosion resistant, have long wear and smooth operation in the bores. Stainless pistons transfer less heat than aluminum designs and reduce the risk of pedal fade from fluid boiling. Cooler caliper temperatures also prevent bore scuffing and piston binding caused by excessive heat distortion. Internal fluid ports eliminate all potential problems associated with external tubes and four corner vertical bleeders allow total evacuation from both sides, regardless of mounting position. A high luster black anodized finish accelerates heat dissipation and preserves this caliper's classic good looks year after year.



Typical Front Dynalite Big Brake Kit

**Drilled and Slotted Rotors** Braking power is radically improved again with the larger 12.19" diameter disc rotors. Compared to the stock rotors, brake leverage is increased by as much as 29% with the larger OD. The .810" thick, vented fin design is the perfect balance between weight and cooling area for outstanding reliability and fade free performance in the toughest conditions. It is also cross-drilled and face-slotted for improved brake feel and pad performance over the full range of light to severe braking. Along with an additional reduction in rotating and unsprung suspension weight, the venting action of holes and the cleaning action of the slots will reduce pad glazing as well as surface heat and minimize uneven pad compound build-up on the rotor faces. After machining, each rotor gets a zinc bath to prevent corrosion and preserve the stylish look inside the wheel. Show quality looks are combined with smoother engagement, consistent pedal feel and confident stopping power under all conditions.

**Aluminum Alloy Brake Hats** Wilwood's brake hats are fully CNC machined for precise fit and engineered for maximum strength with lowest rotating weight. All hats feature multiple wheel stud patterns for use with stock or after market axles and are black anodized for rapid heat dissipation and corrosion resistance..

**Polymatrix Brake Pads** To complete the whole performance package, most Dynalite Big Brake kits ship with PolyMatrix 7112 "D" compound brake pads. "D" compound provides immediate cold response, with strong resistance to fade during periodic, severe high temperature braking. This makes it a great overall performer in everything from light easy traffic stops to hard braking corners at the auto-cross or drag strip. The 7112 style pad is also available in six other compounds to tune any brake system to any track conditions or driving style. Other kits come standard with Wilwood's PolyMatrix "T" compound brake pads. This rotor friendly compound delivers confident stopping power and high resistance to fade, with the lowest dusting and quietest operation of any competition style pad.

**Aluminum Caliper Brackets** Lightweight and CNC machined for precise fit on each spindle application. Steel thread inserts provide strength and durability at the caliper mounting holes, and each bracket is anodized to prevent corrosion and preserve its high tech style.

**Grade 8 and Aircraft Hardware** These elements provide the form, fit and function for precise assembly during installation, and maximum reliability for repeated safe stopping.

**Installation is Simple** The kit is a complete bolt-on without the need to modify any of the stock brake or suspension components and includes detailed instructions. Optional braided stainless steel line kits are available to add the finishing touch to your installation.

**ORDERING INFORMATION:**

MAKE	YEAR	DISC/DRUM	NOTES	BILLET P/N	DRILLED P/N
Chrysler PT Cruiser	2000-01	Disc	(1)		140-6376-D
Ford Pinto / Mustang II	1971-80	Disc	(1)	140-7017	140-7017-D
Honda / Acura Acura / Civic	1994-01	Disc	(1)		140-6163-D
Acura RSX	2002	Disc	(1)		140-7014-D
Civic	1990-99	Disc	(1)		140-6310-D
Mitsubishi Lancer	2002	Disc	(1)		140-7015-D

Notes: (1) Braided stainless steel hose kits are available for some applications.

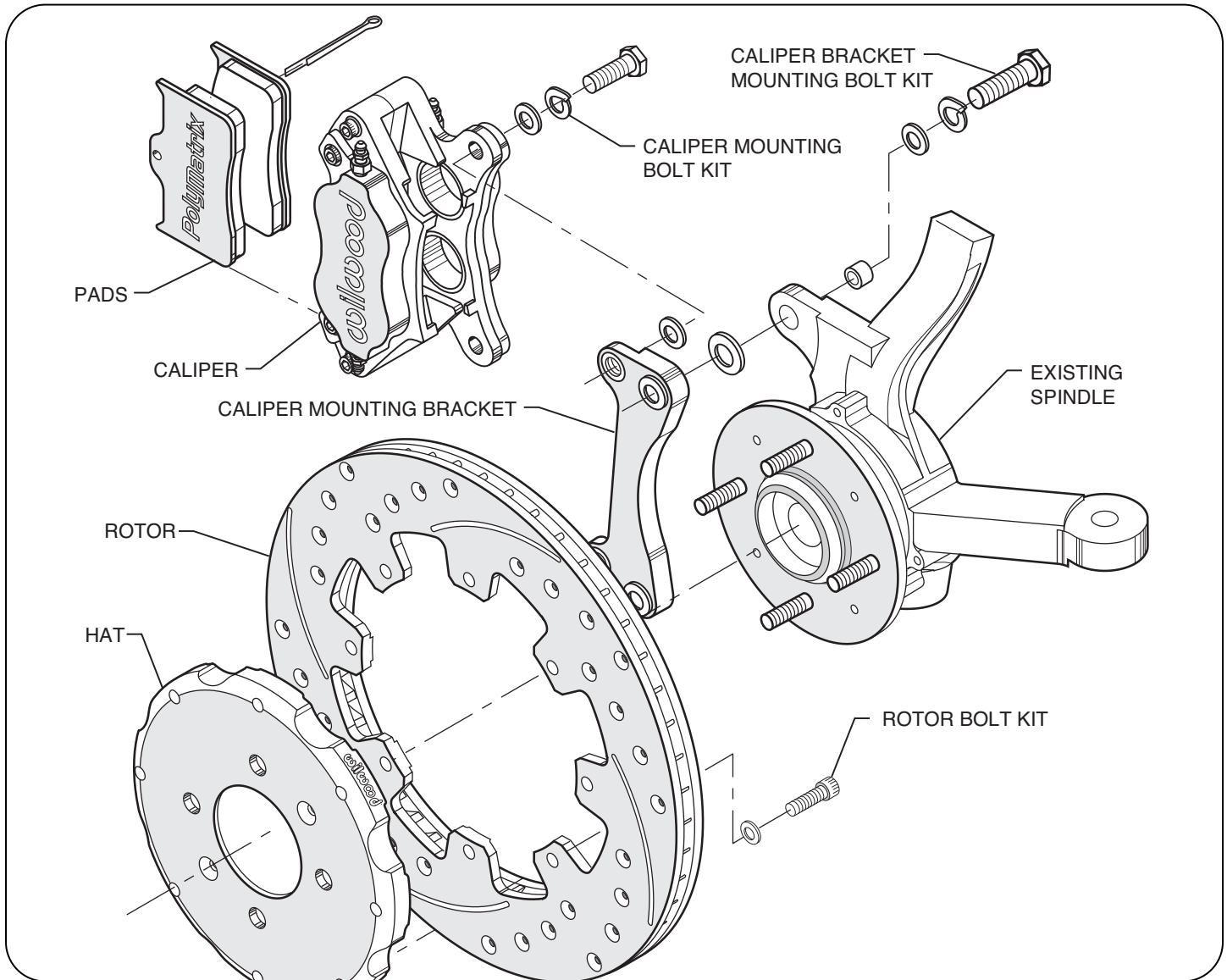

**Front Dynalite Big Brake Kit, Typical Installation Configuration, Major Components Identified**

**ORDERING INFORMATION: USER SERVICEABLE COMPONENTS, PART NUMBER:**

KIT PART NO.	BLK BILLET CALIPER	DRILLED AND SLOTTED ROTOR	HAT	AXLE SET PADS	BRACKET KIT (PAIR)	ROTOR BOLT KIT	CALIPER BOLT KIT	O-RING KIT (4 PK)	INSTALLATION SHEET
140-6163-D	120-5005	160-7103/04	170-6288	15D-4331K	250-6289 (ea)	230-6365	230-0204	130-2658	DS-375
140-6310-D	120-5005	160-7103/04	170-6288	15D-4331K	250-6290 (ea)	230-6365	230-0204	130-2658	DS-376
140-6376-D	120-5319/20	160-7103/04	170-6378	15T-5911K	250-6379 (ea)	230-6365	230-0204	130-2658	DS-385
140-7014-D	120-6923	160-7101/02	170-6947	15E-6096K	250-6289 (ea)	230-6365	230-0204	130-2658	DS-413
140-7015-D	120-6923	160-7101/02	170-6996	15E-6096	250-6995 (ea)	230-6365	230-0204	130-2658	DS-414
140-7017 /-D	120-4997	160-7103/04	-	15T-5911	249-6935/36	230-3484	230-0204	130-2658	DS-415