

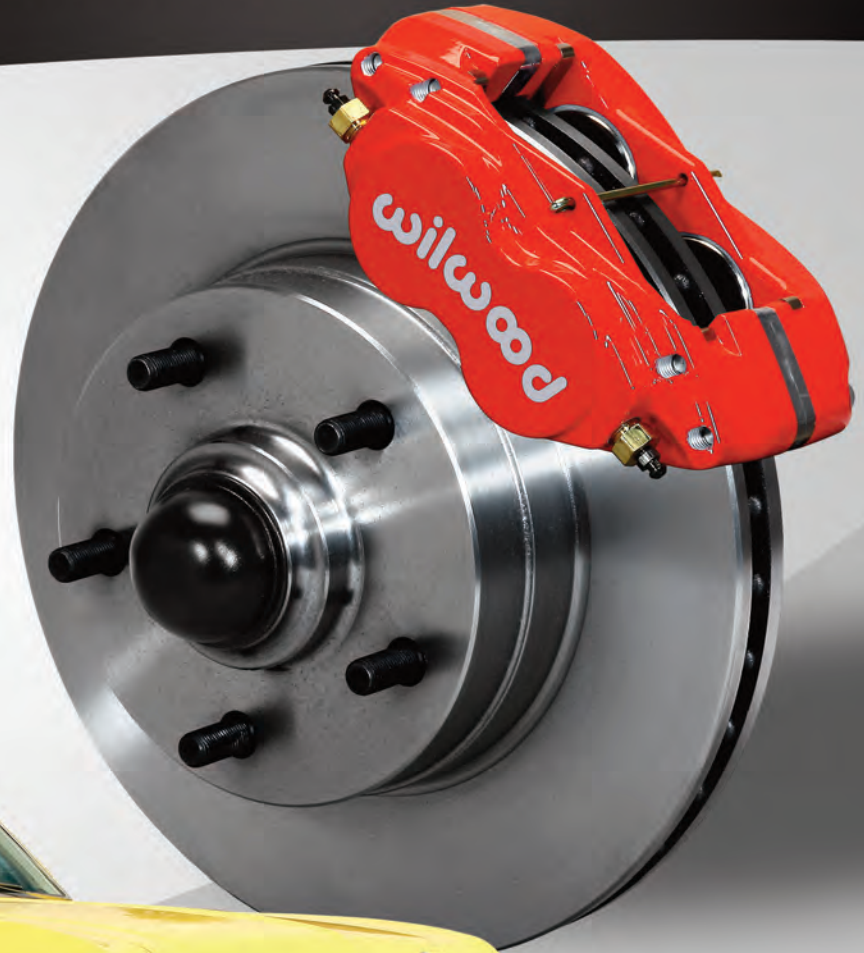

## AFX BODY CLASSIC SERIES FRONT DISC BRAKE KITS

*Classic Series Dynalite front brake kits for the early GM A, F, and X body cars provide an affordable and easy bolt-on solution for upgrading from Original Equipment (OE) drum or disc brakes on these classic year muscle cars.*



### **Kit Features**



- Forged Dynalite four piston aluminum calipers with stainless steel pistons available in black anodized or red powder coat
- Durable 11.00" x 1.00" 1-piece certified alloy precision finish smooth face HP hub and rotor
- Fits all OE drum or disc brake spindles with most 14" and 15" disc brake back spacing wheels
- Can be used manual or with a power booster and matched output master cylinders
- Kits include BP-10 *SmartPads*, bearings, seals, brackets and a detailed instruction guide
- All inclusive kit complete with DOT approved stainless steel braided flexlines and hardware

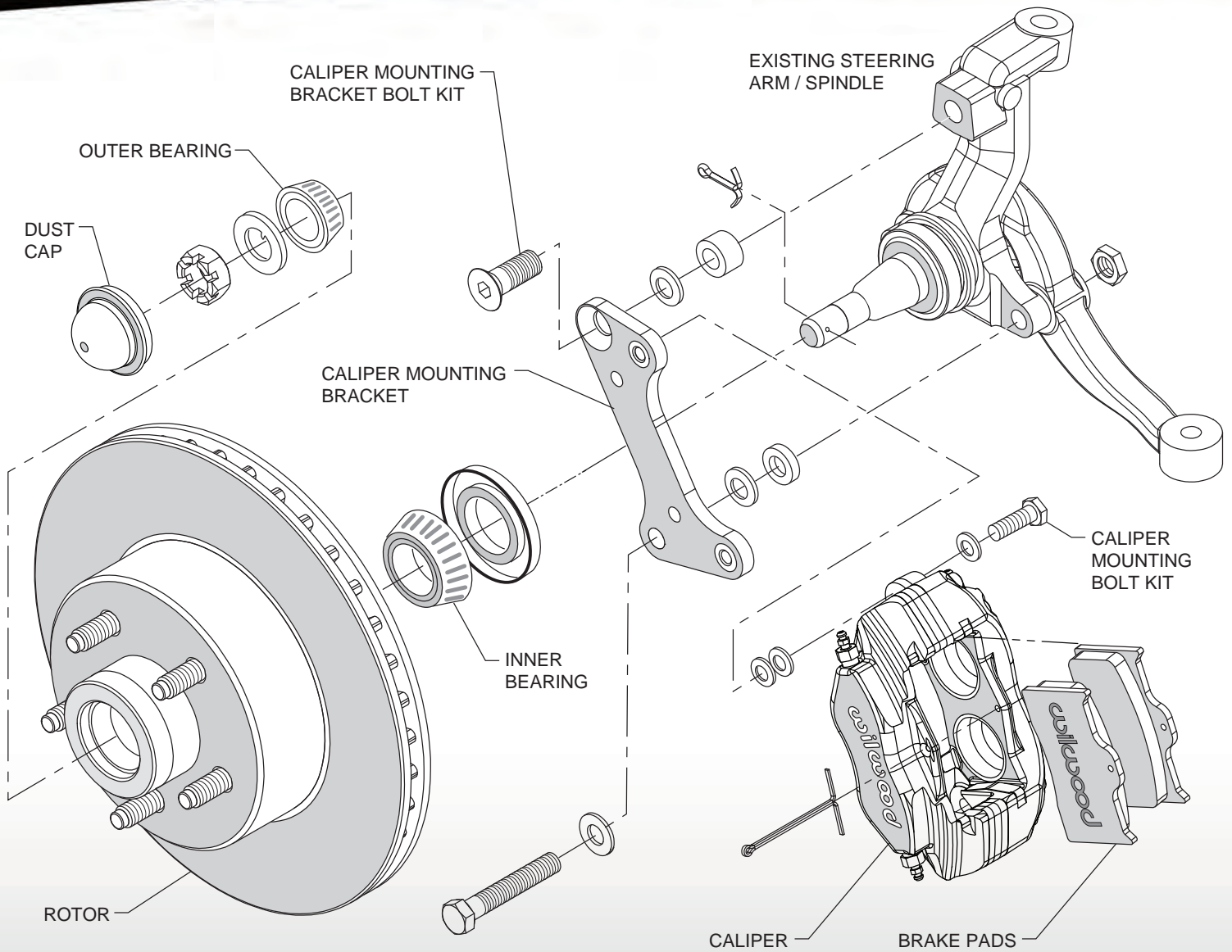

## ORDERING INFORMATION: Complete Front Brake Kits for AFX Body Vehicles

PART NUMBER	DESCRIPTION	CALIPER FINISH
<a href="#">140-15272</a>	Dynalite-M Calipers, 11.00" Diameter 1-Piece Plain Face Rotors	Black Anodize
<a href="#">140-15272-R</a>	Dynalite-M Calipers, 11.00" Diameter 1-Piece Plain Face Rotors	Red Powder Coat