



FORD MUSTANG • 2015-PRESENT DYNAPRO 4R • DRAG RACE REAR BRAKE KIT

DynaPro 4R Drag Race Brake kits

deliver high-torque stopping power with a substantial weight savings over the factory components on Mustangs with OE rear suspensions built specifically for drag racing.



Kit Features



- DynaPro four piston radial mount calipers attach directly to the OE suspension upright with billet radial mount-style brackets
- BP-20 compound *SmartPads* in the calipers provide fast response with strong holding power and resistance to fade on hard stops
- Dynamic mount drilled steel rotors maximize weight savings and resistance against thermal stress and rotor distortion
- Lightweight forged aluminum hats with high strength stainless bolts mount the rotors to the OE hubs
- Parking brakes deleted for more overall weight reduction
- All premium-grade, high-strength fasteners and hardware included
- Braided stainless steel DOT-type flexlines available separately for a complete custom installation

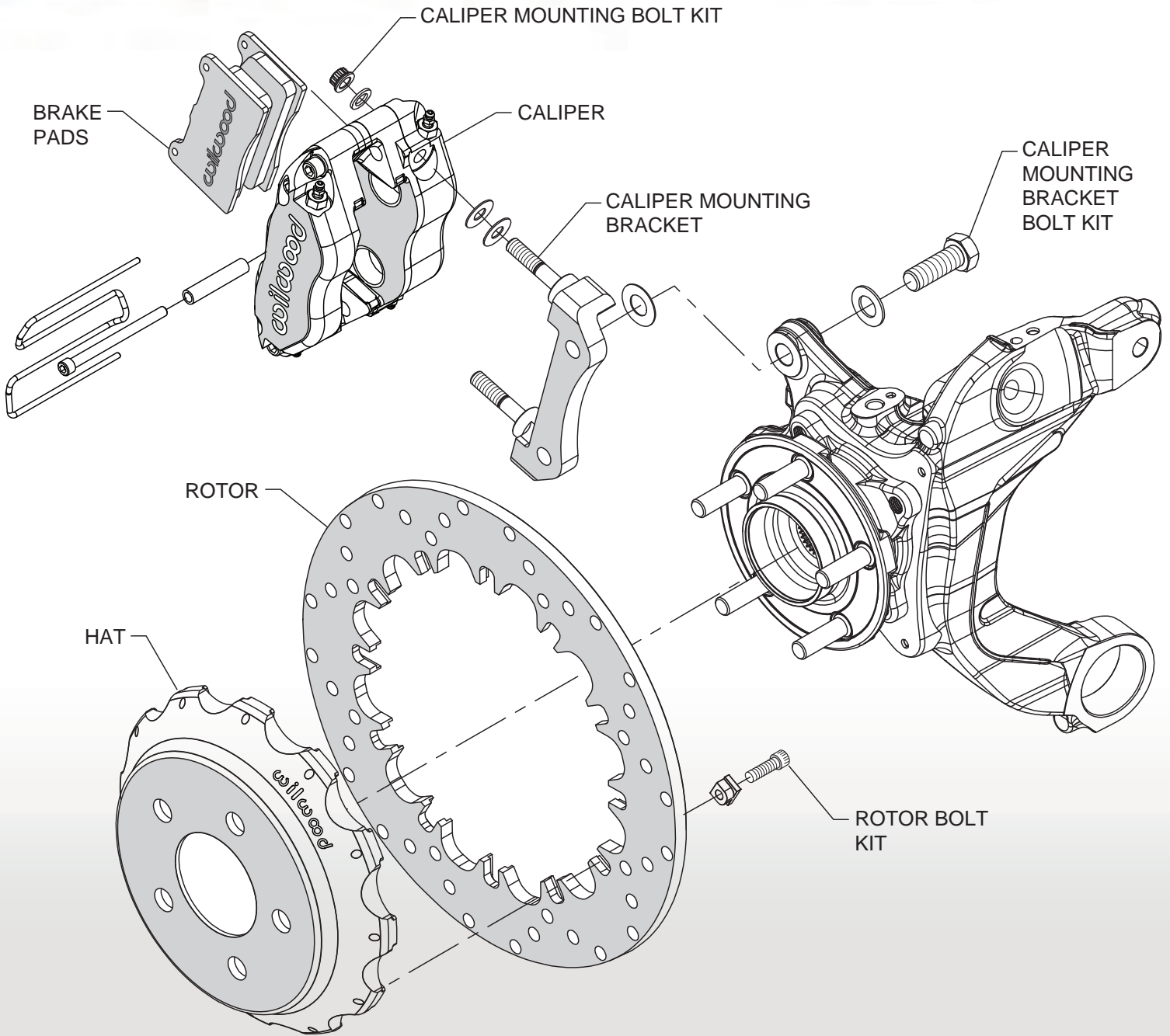

ORDERING INFORMATION: Rear Drag Kit for 2015-Present Ford Mustangs with 17" Wheels

PART NUMBER	DESCRIPTION	CALIPER FINISH
140-14106-D	DynaPro 4R Calipers, 12.90" Diameter x .38" Thick Dynamic Mount Drilled Steel Rotors	Black Anodize
220-12092	Flexline Kit, Braided Stainless Steel with Protective Overlay and DOT Compliant Couplings	N/A

Note: Kit is parking brake delete, requiring removal of the Original Equipment (OE) parking brake components