



MAZDA 3, 2005 & UP DYNAPRO 6 FRONT BRAKE KIT

DynaPro 6 Big Brake kits combine competition proven technology with contemporary styling in a fully bolt-on performance upgrade system for 17" wheel equipped Mazda 3's.



Kit Features

- Fits behind stock 17" wheels
- Easy bolt-on installation
- Engineered for full compatibility with the Original Equipment (OE) master cylinder, brake booster, and ABS
- Optional caliper finishes, rotor styles, and brake pad compounds
- Easily custom tailored for the street or track
- DynaPro 6 aluminum calipers
- 12.88" x 1.10" directional vane iron alloy two-piece rotor assemblies with aluminum mounting hats
- BP-10 metallic-composite compound *Smart Pads*
- DOT approved stainless steel flexlines

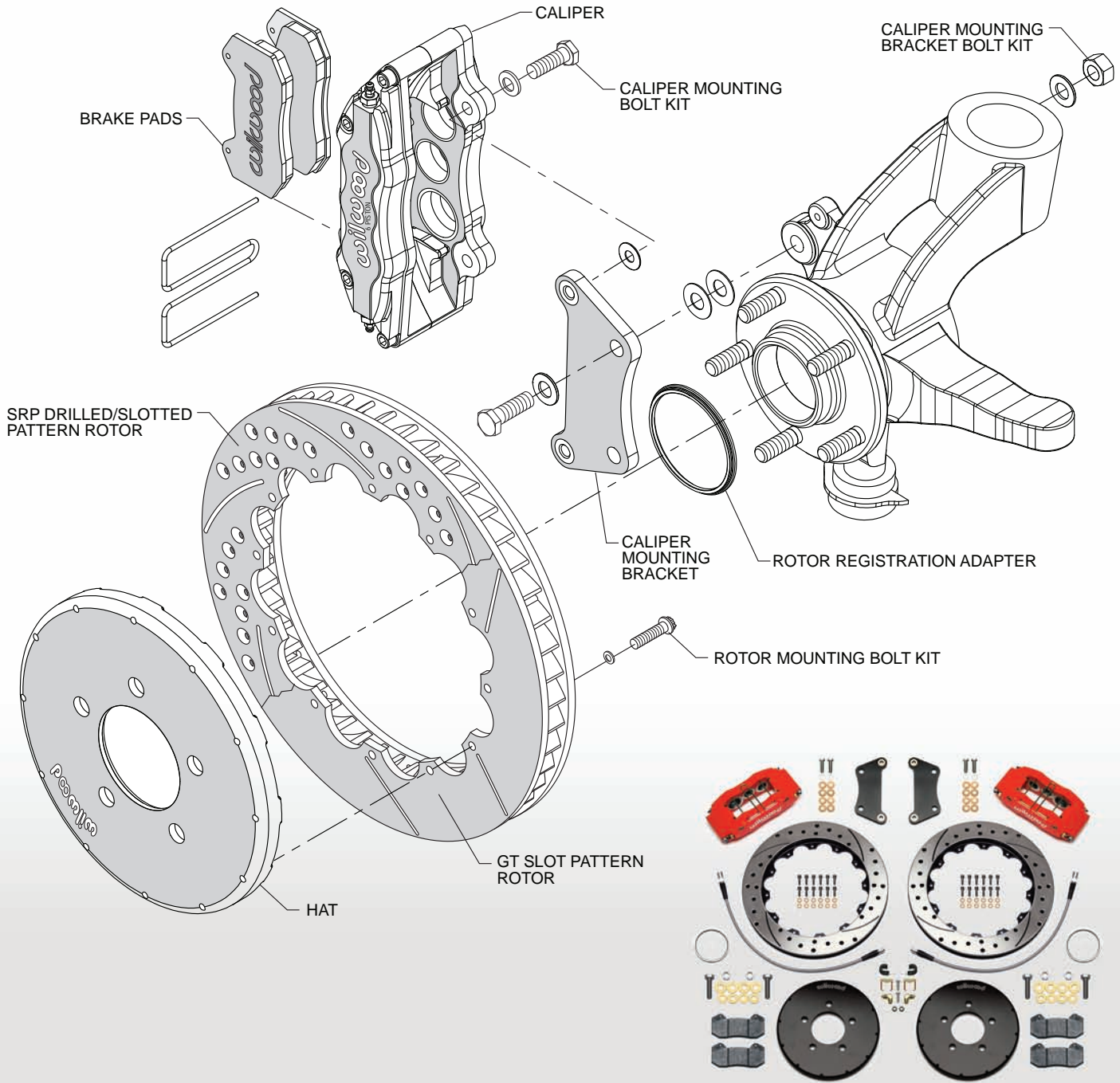

ORDERING INFORMATION:

PART NUMBER	DESCRIPTION
140-13581	Front Kit, 2005-Up Mazda 3, DynaPro 6 Caliper, 12.88" GT Rotor, Black Caliper
140-13581-D	Front Kit, 2005-Up Mazda 3, DynaPro 6 Caliper, 12.88" SRP Drilled and Slotted Rotor, Black Caliper
140-13581-DR	Front Kit, 2005-Up Mazda 3, DynaPro 6 Caliper, 12.88" SRP Drilled and Slotted Rotor, Red Caliper
140-13581-R	Front Kit, 2005-Up Mazda 3, DynaPro 6 Caliper, 12.88" GT Rotor, Red Caliper