

1966-77 FORD BRONCO FRONT FNLS4R BRAKE KITS

Models Covered:

- 1966-1975 Ford Bronco Dana 30/44 Drum Axle
- 1976-1977 Ford Bronco Dana 44 Disc Axle

Kit Features:

- Upgrade from Original Equipment (OE) brakes to four piston Forged Superlite 4 Radial Mount calipers.
- 12.88", or 14.00" diameter **Spec 37** rotors in either HD plain face, GT slotted, or SRP drilled and slotted.
- Simple bolt-on installation with no modifications required.
- 12.88" diameter kits fit most 17" wheels; 14.00" diameter kits fit most 18" and larger wheels.

Component Features:

FNLS4R Radial Mount Four Piston Calipers

- Competition proven forged billet aluminum bodies demonstrate superior strength and resistance to deflection and separation under high load.
- Four symmetrical bore pistons generate high clamping force for optimized stopping power.
- Stainless steel pistons resist corrosion while slowing the heat transfer rate from the pads to the caliper body, fluid and seals.
- The caliper's seal-in-bore design adds proven durability, keeping the fluid in and dirt out without the need for external boot seals.
- Spring loaded stainless steel SRS bridge plates dampen pad noise and protect the caliper bridges from wear.
- Calipers provide easy access to the pads for service, without the need to unbolt the calipers from their mounts.
- Calipers are available with either black or red high-gloss, high temperature, brake fluid resistant sealed powder coat and feature Wilwood's signature logo. "Quick-Silver" finish calipers are also available by special order.

Spec 37 Material 12.88" x 1.25" or 14.00" x 1.25" Rotor Options

- **Spec 37** rotors are manufactured from a proprietary iron alloy developed to withstand extreme temperatures with the highest possible degree of resistance against distortion, warping, cracking, and wear.
- **GT** competition series rotors feature full detail machining with asymmetrical slots in the faces. GT rotors provide the highest degree of durability and longer life for repeated hard braking and high temperature use.
- **SRP** rotors feature our signature performance drilled and slotted pattern with a durable e-coat finish. E-coat seals the casting and prevents corrosion in all areas of the rotor not swept clean by the brake pads. This resilient finish will maintain the high tech styling and appearance of the rotors inside your wheels for many miles down the road.
- **HD** plain face rotors are precision machined for smoother engagement and provide long service life, superior thermal stability and improved fatigue resistance.

Forged Aluminum GT Mounting Hats

- 5 x 5.50" B.C. pattern fits directly on OE axles with .50" wheel studs
- Forged aluminum rotor mounting hats help reduce weight with the strength to handle the exceptional brake torque delivered by the calipers.
- Black E-coat finish resists corrosion while adding to the aggressive competition look inside the wheel.

Wilwood "Smart Pads"

- Kits include our proven formula BP-10 Smart Pads. BP-10 is a unique composite-metallic compound that provides increased friction, stopping power, and higher fade resistance in a clean and quiet-running, low-dust style pad.
- Optional high-temperature and race-only pad compounds are also available.

Radial Mounting Brackets, Hardware and Plumbing

- Radial mounting provides secure attachment directly to the OE mounts, with two planes of adjustment for precise alignment of the caliper over the rotor. Caliper brackets, premium grade hardware, and detailed installation instructions are included in every kit.
- Jacketed stainless steel braided, DOT approved flexlines are included.



FNLS4R HD Kit Assembly

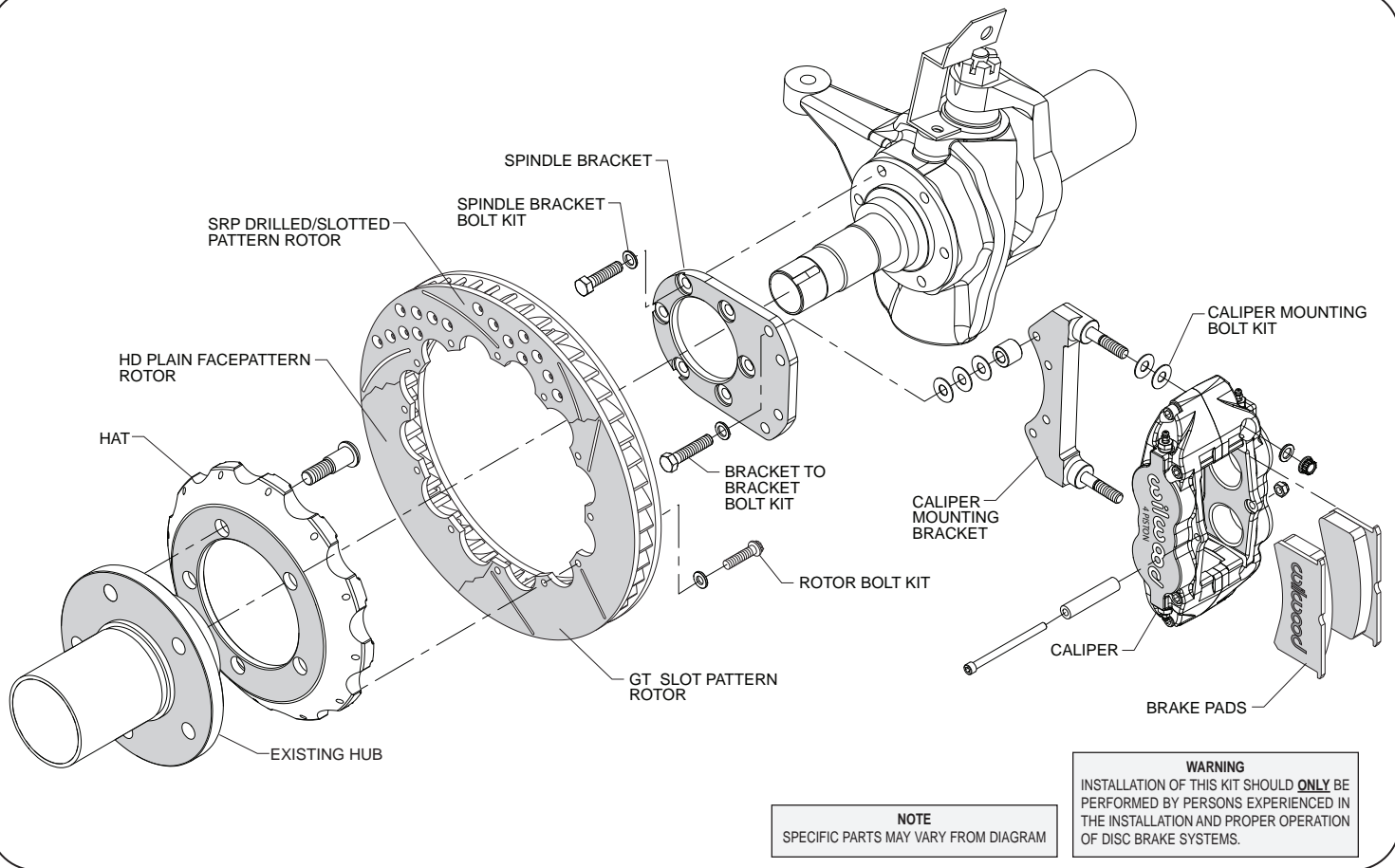

Typical Installation Diagram (12.88" Kit Shown)

ORDERING INFORMATION:

PART NUMBER

DESCRIPTION

PART NUMBER	DESCRIPTION
140-13304	1966-75 Ford Bronco, Dana 30/44 Drum Spindle, FNSL4R Caliper, 12.88" HD Rotor, Black Caliper
140-13304-D	1966-75 Ford Bronco, Dana 30/44 Drum Spindle, FNSL4R Caliper, 12.88" SRP Drilled and Slotted Rotor, Black Caliper
140-13304-R	1966-75 Ford Bronco, Dana 30/44 Drum Spindle, FNSL4R Caliper, 12.88" HD Rotor, Red Caliper
140-13304-DR	1966-75 Ford Bronco, Dana 30/44 Drum Spindle, FNSL4R Caliper, 12.88" SRP Drilled and Slotted Rotor, Red Caliper
140-13305	1976-77 Ford Bronco, Dana 44 Disc Spindle, FNSL4R Caliper, 12.88" HD Rotor, Black Caliper
140-13305-D	1976-77 Ford Bronco, Dana 44 Disc Spindle, FNSL4R Caliper, 12.88" SRP Drilled and Slotted Rotor, Black Caliper
140-13305-R	1976-77 Ford Bronco, Dana 44 Disc Spindle, FNSL4R Caliper, 12.88" HD Rotor, Red Caliper
140-13305-DR	1976-77 Ford Bronco, Dana 44 Disc Spindle, FNSL4R Caliper, 12.88" SRP Drilled and Slotted Rotor, Red Caliper
140-13329	1966-75 Ford Bronco, Dana 30/44 Drum Spindle, FNSL4R Caliper, 14.00" GT Rotor, Black Caliper
140-13329-D	1966-75 Ford Bronco, Dana 30/44 Drum Spindle, FNSL4R Caliper, 14.00" SRP Drilled and Slotted Rotor, Black Caliper
140-13329-R	1966-75 Ford Bronco, Dana 30/44 Drum Spindle, FNSL4R Caliper, 14.00" GT Rotor, Red Caliper
140-13329-DR	1966-75 Ford Bronco, Dana 30/44 Drum Spindle, FNSL4R Caliper, 14.00" SRP Drilled and Slotted Rotor, Red Caliper
140-13330	1976-77 Ford Bronco, Dana 44 Disc Spindle, FNSL4R Caliper, 14.00" GT Rotor, Black Caliper
140-13330-D	1976-77 Ford Bronco, Dana 44 Disc Spindle, FNSL4R Caliper, 14.00" SRP Drilled and Slotted Rotor, Black Caliper
140-13330-R	1976-77 Ford Bronco, Dana 44 Disc Spindle, FNSL4R Caliper, 14.00" GT Rotor, Red Caliper
140-13330-DR	1976-77 Ford Bronco, Dana 44 Disc Spindle, FNSL4R Caliper, 14.00" SRP Drilled and Slotted Rotor, Red Caliper