



# 1966-77 FORD BRONCO DYNAPRO REAR PARKING BRAKE KITS

## Kit Features:

- Compatible with Small, Big, and Big Bearing New Style Ford Broncos, 5 x 5.50" bolt circle.
- Upgrade from Original Equipment (OE) brakes to four piston forged DynaPro calipers.
- 12.19" diameter rotors in either HP plain face or SRP drilled and slotted.
- Simple bolt-on installation with no modifications required.
- Fits most 15" and larger wheels.

## Component Features:

### Calipers

- DynaPro 4 Piston Lung Mount Calipers
- Competition proven forged billet aluminum bodies demonstrate superior strength and resistance to deflection and separation under high load.
- Four symmetrical bore pistons generate high clamping force for optimized stopping power.
- Stainless steel pistons resist corrosion while slowing the heat transfer rate from the pads to the caliper body, fluid and seals.
- The caliper's seal-in-bore design adds proven durability, keeping the fluid in and dirt out without the need for external boot seals.
- Spring loaded stainless steel SRS bridge plates dampen pad noise and protect the caliper bridges from wear.
- Quick-E clip pad retention pins simplify pad service without the need for caliper removal.
- Calipers are available with either black or red high-gloss, high temperature, brake fluid resistant sealed powder coat and feature Wilwood's signature logo.

### Rotors (12.19" x .81")

- SRP rotors feature our signature performance drilled and slotted pattern with a durable e-coat finish. E-coat seals the casting and prevents corrosion in all areas of the rotor not swept clean by the brake pads. This resilient finish will maintain the high tech styling and appearance of the rotors inside your wheels for many miles down the road.
- HP plain face rotors are precision machined for smoother engagement and provide long service life, superior thermal stability and improved fatigue resistance.

### Parking Brake

- The drum style internal parking brake provides outstanding holding power with the ultimate uncluttered custom look.
- The two shoe system is mechanically actuated and spring loaded for quiet non-rattling performance.
- Brake shoes are neatly hidden and out-of-sight inside the rotor assembly. Parking brake cables are relocated inward with more clearance for deep offset wheels.

### Brake Pads

- Kits include our proven formula BP-10 Smart Pads. BP-10 is a unique composite-metallic compound that provides increased friction, stopping power, and higher fade resistance in a clean and quiet-running, low-dust style pad.
- Optional high-temperature and race-only pad compounds are also available.

### Hardware

- Caliper brackets, premium grade hardware, and detailed installation instructions are included in every kit.
- Jacketed stainless steel braided, DOT approved flexline are included.

### Note:

- Clevis and cable kits, which attach to the parking brake assembly, are not included in the Wilwood parking brake kits. Wilwood offers a universal style cable kit for this vehicle, order part number 330-9371.



DynaPro Kit Assembly

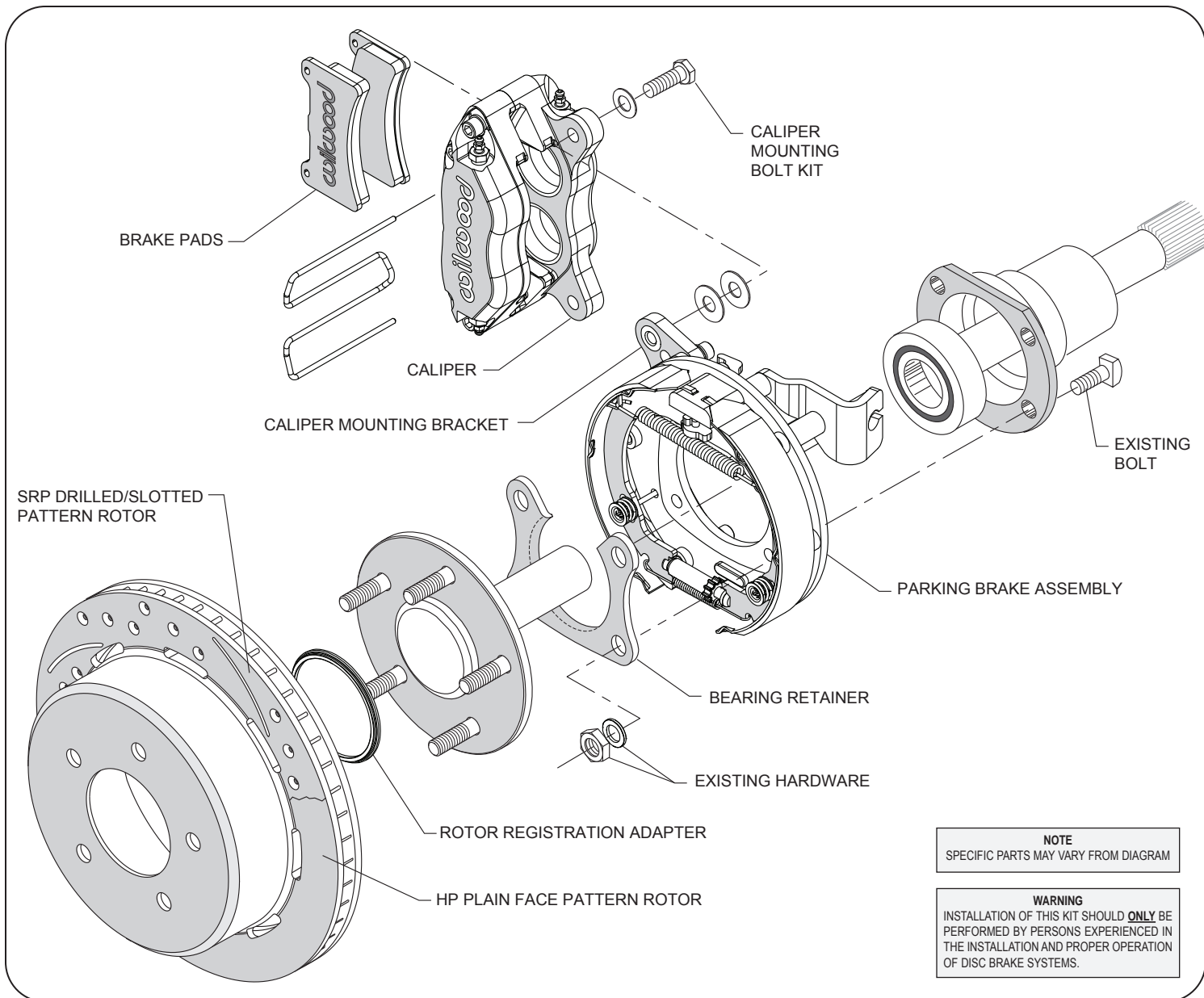

Typical Installation Diagram

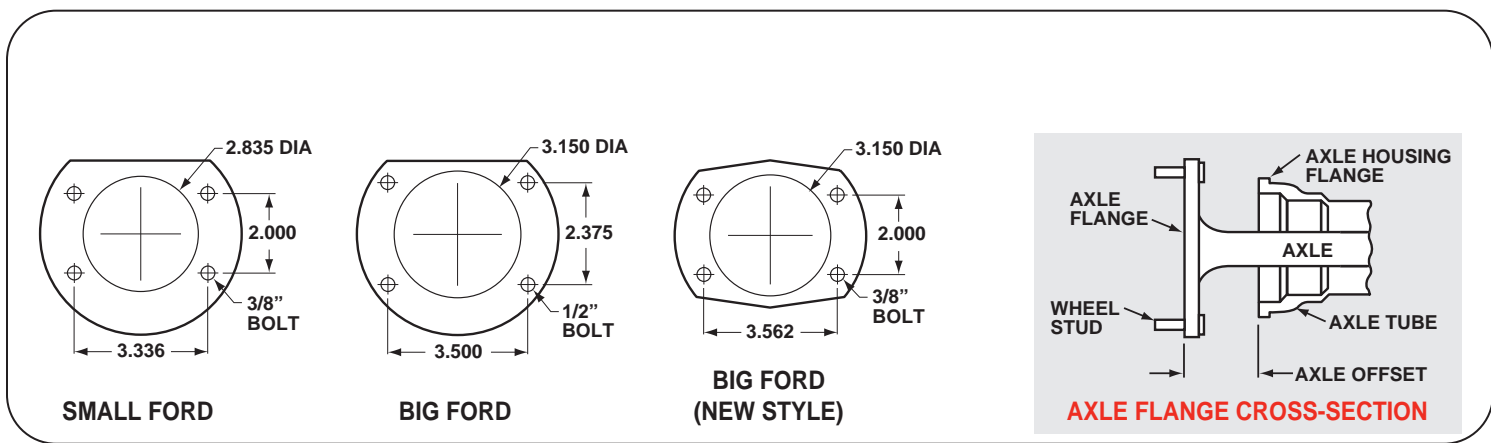

Bronco Housing Flange / Axle Offset

**ORDERING INFORMATION:**

<b><u>PART NUMBER</u></b>	<b><u>DESCRIPTION</u></b>
140-13320	Small Bearing Ford, 2.36" Offset, 5 x 5.50" BC, DynaPro Caliper, 12.19" HP Rotor, Black Caliper
140-13320-D	Small Bearing Ford, 2.36" Offset, 5 x 5.50" BC, DynaPro Caliper, 12.19" SRP Drilled & Slotted Rotor, Black Caliper
140-13320-R	Small Bearing Ford, 2.36" Offset, 5 x 5.50" BC, DynaPro Caliper, 12.19" HP Rotor, Red Caliper
140-13320-DR	Small Bearing Ford, 2.36" Offset, 5 x 5.50" BC, DynaPro Caliper, 12.19" SRP Drilled and Slotted Rotor, Red Caliper
140-13322	Big Bearing Ford, 2.36" Offset, 5 x 5.50" BC, DynaPro Caliper, 12.19" HP Rotor, Black Caliper
140-13322-D	Big Bearing Ford, 2.36" Offset, 5 x 5.50" BC, DynaPro Caliper, 12.19" SRP Drilled and Slotted Rotor, Black Caliper
140-13322-R	Big Bearing Ford, 2.36" Offset, 5 x 5.50" BC, DynaPro Caliper, 12.19" HP Rotor, Red Caliper
140-13322-DR	Big Bearing Ford, 2.36" Offset, 5 x 5.50" BC, DynaPro Caliper, 12.19" SRP Drilled and Slotted Rotor, Red Caliper
140-13733	Big Bearing Ford, 2.00" Offset, 5 x 5.50" BC, DynaPro Caliper, 12.19" HP Rotor, Black Caliper
140-13733-D	Big Bearing Ford, 2.00" Offset, 5 x 5.50" BC, DynaPro Caliper, 12.19" SRP Drilled and Slotted Rotor, Black Caliper
140-13733-R	Big Bearing Ford, 2.00" Offset, 5 x 5.50" BC, DynaPro Caliper, 12.19" HP Rotor, Red Caliper
140-13733-DR	Big Bearing Ford, 2.00" Offset, 5 x 5.50" BC, DynaPro Caliper, 12.19" SRP Drilled and Slotted Rotor, Red Caliper
140-13664	Big Bearing Ford, New Style, 2.38" Offset, 5 x 5.50" BC, DynaPro Caliper, 12.19" HP Rotor, Black Caliper
140-13664-D	Big Bearing Ford, New Style, 2.38" Offset, 5 x 5.50" BC, DynaPro Caliper, 12.19" SRP Drilled and Slotted Rotor, Black Caliper
140-13664-R	Big Bearing Ford, New Style, 2.38" Offset, 5 x 5.50" BC, DynaPro Caliper, 12.19" HP Rotor, Red Caliper
140-13664-DR	Big Bearing Ford, New Style, 2.38" Offset, 5 x 5.50" BC, DynaPro Caliper, 12.19" SRP Drilled and Slotted Rotor, Red Caliper