



# COMBINATION PARKING BRAKE REAR KIT FOR 2013 FORD FOCUS ST

## Models Covered:

- 2013 Ford Focus ST

## Kit Features:

- Combination hydraulic-mechanical parking brake calipers use hydraulic pressure for stopping and a mechanical lock for parking.
- 12.88" rotor provides improved stopping power, balanced rear bias, and competitive styling to compliment front brake upgrades in conjunction with wheel, tire, and suspension modifications.
- Caliper brackets and installation hardware are engineered specific to the Ford Focus ST.
- Simple bolt-on installation and fully compatible with ABS and OE master cylinder output.



## Component Features:

### Combination Hydra-Mechanical Parking Brake Caliper

- Single piston floating mount calipers are securely attached to the upright with a fixed radial mount bracket.
- The floating mount caliper maintains perfect alignment when the cable actuated mechanical parking brake lock is engaged and then released.
- Correct alignment is maintained over the disc as the pads wear and pad knock back is minimized.
- Radial mounting provides secure attachment to the caliper mounting bracket and precise adjustments for pad to rotor alignment.
- The caliper's parking brake cable bracket accepts the OE cable end with minor modifications.

Combination Caliper Rear  
Parking Brake Kit with SRP Rotor

### GT or SRP Series 12.88" x 0.81" Rotor Options

- GT competition series rotors feature full detail machining with asymmetrical slots in the faces. GT rotors provide the highest degree of durability and longer life for repeated hard braking and high temperature use.
- Drilled rotor kits feature our signature SRP performance drilled and slotted rotors with a durable e-coat finish. E-coat seals the casting and prevents corrosion in all areas of the rotor not swept clean by the brake pads. This durable finish will maintain the high tech styling and appearance of the rotors inside your wheels for many miles down the road.

### Forged Aluminum GT Mounting Hats

- Premium grade alloy forged aluminum rotor mount hats are light to reduce rotating weight and strong to provide secure mounting of the rotor.
- Black E-coat finish resists corrosion while adding to the aggressive competition look inside the wheel.

### Wilwood BP-10 "Smart Pads"

- Kits include our proven formula BP-10 Smart Pads. BP-10 is a unique composite-metallic compound that provides increased friction, stopping power, and higher fade resistance in a clean and quiet running low dust style pad.
- Optional high-temp and race only pad compounds are also available.

### Mounting Hardware and Plumbing

- Caliper mounts are engineered for precise fit and secure installation. Premium grade fasteners and alignment shims are included for a professional installation.
- Stainless steel braided flexline kits with machine crimped ends include the fittings necessary to connect the calipers to the OE brake line fitting at the chassis and are included with the kit.

**WARNING**  
 INSTALLATION OF THIS KIT SHOULD **ONLY** BE PERFORMED BY PERSONS EXPERIENCED IN THE INSTALLATION AND PROPER OPERATION OF DISC BRAKE SYSTEMS.

**NOTE**  
 SPECIFIC PARTS MAY VARY FROM DIAGRAM

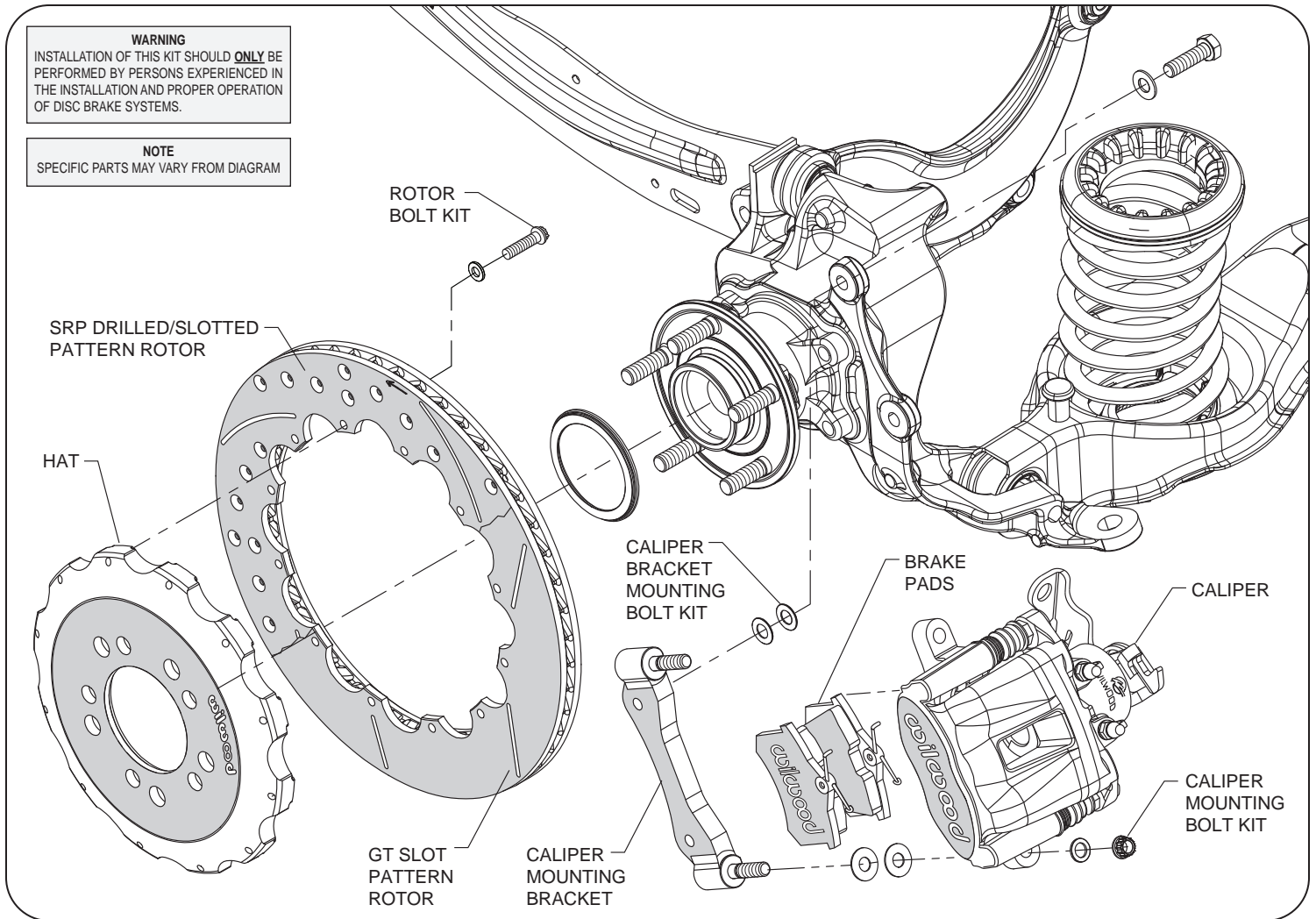

**Typical Installation Diagram, Major Components Identified.**

**ORDERING INFORMATION:**

**PART NUMBER**

**DESCRIPTION**

140-13031	Rear Parking Brake Kit, Ford Focus ST, CPB Caliper, 12.88" GT Rotor, Black Caliper
140-13031-D	Rear Parking Brake Kit, Ford Focus ST, CPB Caliper, 12.88" SRP Drilled and Slotted Rotor, Black Caliper
140-13031-DR	Rear Parking Brake Kit, Ford Focus ST, CPB Caliper, 12.88" SRP Drilled and Slotted Rotor, Red Caliper
140-13031-R	Rear Parking Brake Kit, Ford Focus ST, CPB Caliper, 12.88" GT Rotor, Red Caliper