



# W6AR FRONT BIG BRAKE KIT FOR 1997-2003 FORD F-150 TRUCK

## Models Covered:

- 1997 - 2003 Ford F-150 Truck, 2-Wheel Drive Only

## Kit Features:

- Upgrade from OE calipers to Forged W6AR six piston calipers for heavy duty street applications.
- Choose either 14.25" diameter GT slotted or SRP drilled and slotted rotors.
- Simple bolt-on installation with no modifications required.
- Fully compatible with ABS and OE master cylinder output.

## Component Features:

### W6AR Radial Mount Six-Piston Calipers

- Competition proven forged billet bodies demonstrates superior strength and resistance to deflection and separation under high load.
- Six differential bore pistons generate big brake clamping power with balanced pad loading for even wear in all types of high demand braking applications.
- W6AR calipers use stainless pistons to resist corrosion and reduce heat transfer from the pads to the caliper body.
- The internal piston seal-in-bore design adds proven durability with keeping the fluid in and dirt out without the need for external boot seals.
- Spring loaded SRS bridge plates dampen noise and engagement harmonics while protecting the caliper bridge from wear by pad gouging.
- Standard part number kits are available with either black or red gloss powder coated calipers. Nickel plated "Quick-Silver" series calipers are also available by special order.

### GT or SRP Series Directional Vane 14.25" Rotors

- Directional vane rotors provide the highest degree of cooling efficiency with increased surface area and improved air circulation between the rotor faces.
- GT competition series rotors feature full detail machining with asymmetrical pad cleaning slots in the faces. GT rotors provide the highest degree of durability for repeated hard braking and high temperature use (like pulling a trailer).
- Drilled rotor kits feature our signature SRP performance drilled and slotted rotors with a durable e-coat finish. E-coat seals the casting and prevents corrosion in all areas of the rotor not swept clean by the brake pads. This durable finish will maintain the high tech styling and appearance of the rotors inside your wheels for many miles down the road.

### Forged Aluminum Hubs and Hats

- Fully machined forged aluminum hubs with 1/2-20 grade 8 wheel studs mount to the OE spindle using tapered roller bearings and races.
- Forged GT series competition style hats are face mounted and bolt secured to provide ultimate mounting strength for big brake torque from the 14.25" rotors.
- Wilwood hubs come complete with new Original Equipment specification Reluctor Rings.

### Wilwood BP-10 "Smart Pads"

- BP-10 metallic-composite compound "Smart Pads" run clean and quiet with improved friction, positive response, and higher fade resistance over all types of OE and street rated pad compounds.

### Radial Mounting Brackets, Hardware and Plumbing

- Radial mounting provides secure attachment directly to the OE mounts, with two planes of adjustment for precise alignment of the caliper over the rotor. Brackets, premium grade fasteners and alignment shims are included in each kit.
- Jacketed stainless steel braided, DOT approved flexline kit required to finish the installation on this kit are included.



**Big Brake Front Kit Assembly  
with Red Caliper and SRP Rotor**

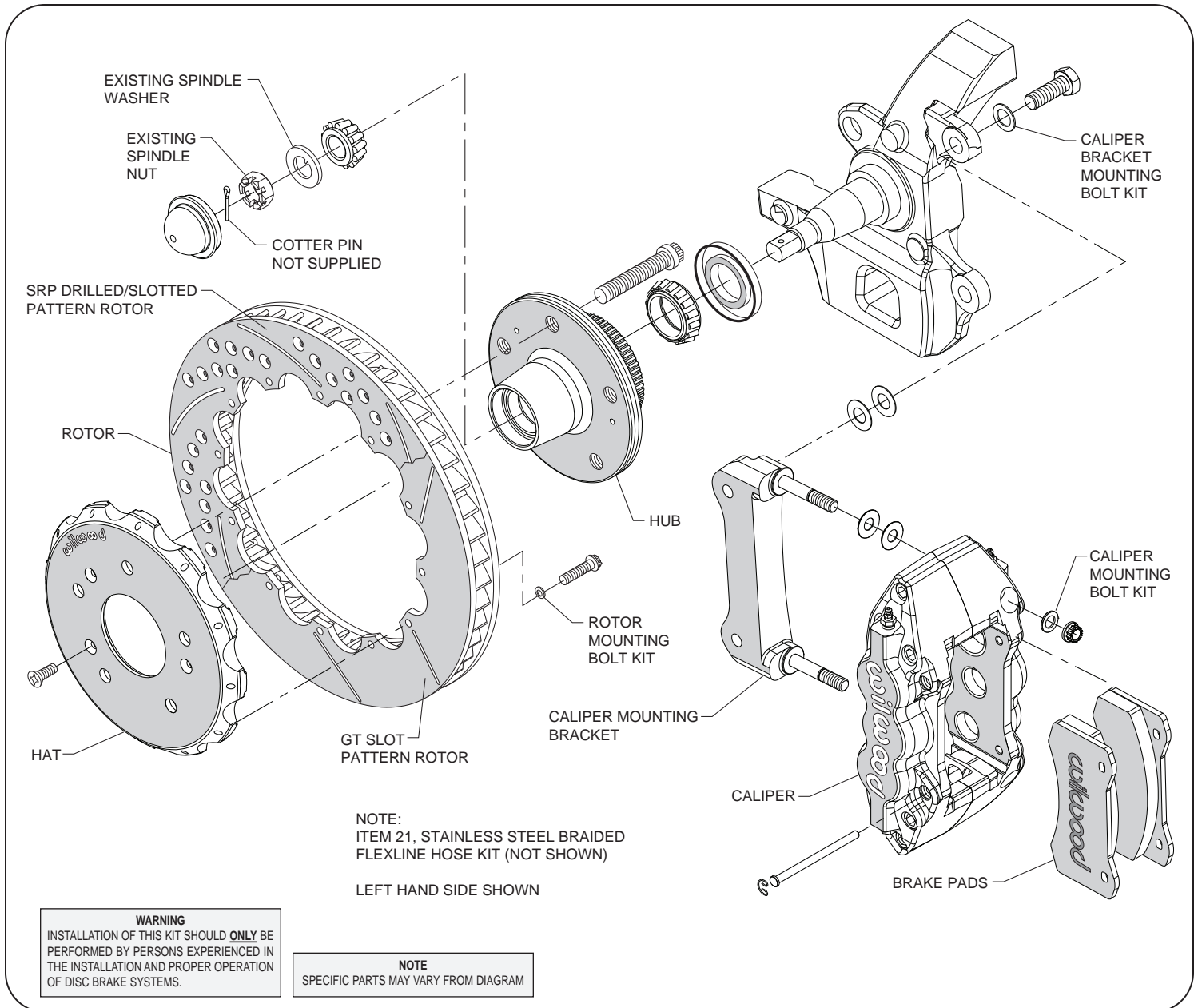

**Typical Installation Diagram**

**ORDERING INFORMATION:**

<b>PART NUMBER</b>	<b>DESCRIPTION</b>
140-12824	Front Kit, Ford F-150 Pickup, 2-Wheel Drive, W6AR Caliper, 14.25" GT Rotor
140-12824-D	Front Kit, Ford F-150 Pickup, 2-Wheel Drive, W6AR Caliper, 14.25" SRP Drilled and Slotted Rotor
140-12824-R	Front Kit, Ford F-150 Pickup, 2-Wheel Drive, W6AR Caliper, 14.25" GT Rotor, Red Caliper
140-12824-DR	Front Kit, Ford F-150 Pickup, 2-Wheel Drive, W6AR Caliper, 14.25" SRP Drilled & Slotted Rotor, Red Caliper