

DYNAPRO 6 FRONT BRAKE KIT FOR FIAT 500 2012-PRESENT

Models Covered:

- Fiat 500 2012 - Present

Kit Features:

- Performance upgrade from 4-piston calipers for aggressive street / track vehicles and dedicated competition machines.
- Simple bolt-on installation with no modifications required.
- Fully compatible with ABS and OE master cylinder output.

Component Features:

DynaPro 6 Forged Billet Lug Mount Calipers

- Fully detail machined forged billet DP6 calipers provide positive, big brake stopping power with a substantial weight reduction over the OE cast iron calipers, and more than a 14% increase in pad area and volume compared to standard Dynalite four piston models.
- Six differential bore stainless steel pistons generate big brake clamping power with balanced pad loading for even wear in all types of high demand braking applications.
- Stainless steel pistons resist corrosion while slowing the heat transfer rate from the pads to the caliper body.
- The internal piston seal-in-bore design adds proven durability with keeping the fluid in and dirt out without the need for external boot seals.
- Quick-E clip pad retention pins simplify pad service without the need for caliper removal.
- High temperature, fluid resistant, gloss black powder coat finish is standard. Optional gloss red powder coat and polished models are also available.

SRP or ULHP Series 12.19" Diameter Rotors

- Directional vane rotors provide the highest degree of cooling efficiency with increased surface area and improved air circulation between the rotor faces.
- ULHP rotors provide high performance and rugged durability for a wide range of competition, performance, and sport driving applications. Rotors are cast from premium grade, long grain carbon iron.
- Drilled rotor kits feature our signature SRP performance drilled and slotted rotors with a durable e-coat finish. E-coat seals the casting and prevents corrosion in all areas of the rotor not swept clean by the brake pads. This durable finish will maintain the high tech styling and appearance of the rotors inside your wheels for many miles down the road.

Forged Aluminum GT Mounting Hats

- Forged aluminum rotor mount hats help reduce weight with the strength to handle the exceptional brake torque delivered by the DynaPro 6 caliper.
- Black anodized finish resists corrosion while adding to the aggressive competition look inside the wheel.

Wilwood BP-10 "Smart Pads"

- All kits include BP-10 metallic-composite compound "Smart Pads". BP-10 delivers the increased friction; higher fade resistance, and longer wear of an entry-level track pad, with virtually noise and dust free performance for the street.
- Optional race-only compounds can be ordered to suit the braking requirements at all levels of severe duty and sustained high heat competition.

Hardware and Plumbing

- Installation is simple. The kit is a complete bolt-on without the need to modify any of the existing brake or suspension components. Aluminum mounting brackets and premium grade hardware are supplied with detailed installation instructions in every kit.
- Stainless steel braided competition flex line kits, with machine crimped ends and the fittings necessary to connect the calipers with the OE chassis bulkhead are included with the kit.



Front Kit with SRP Rotor and Red Caliper

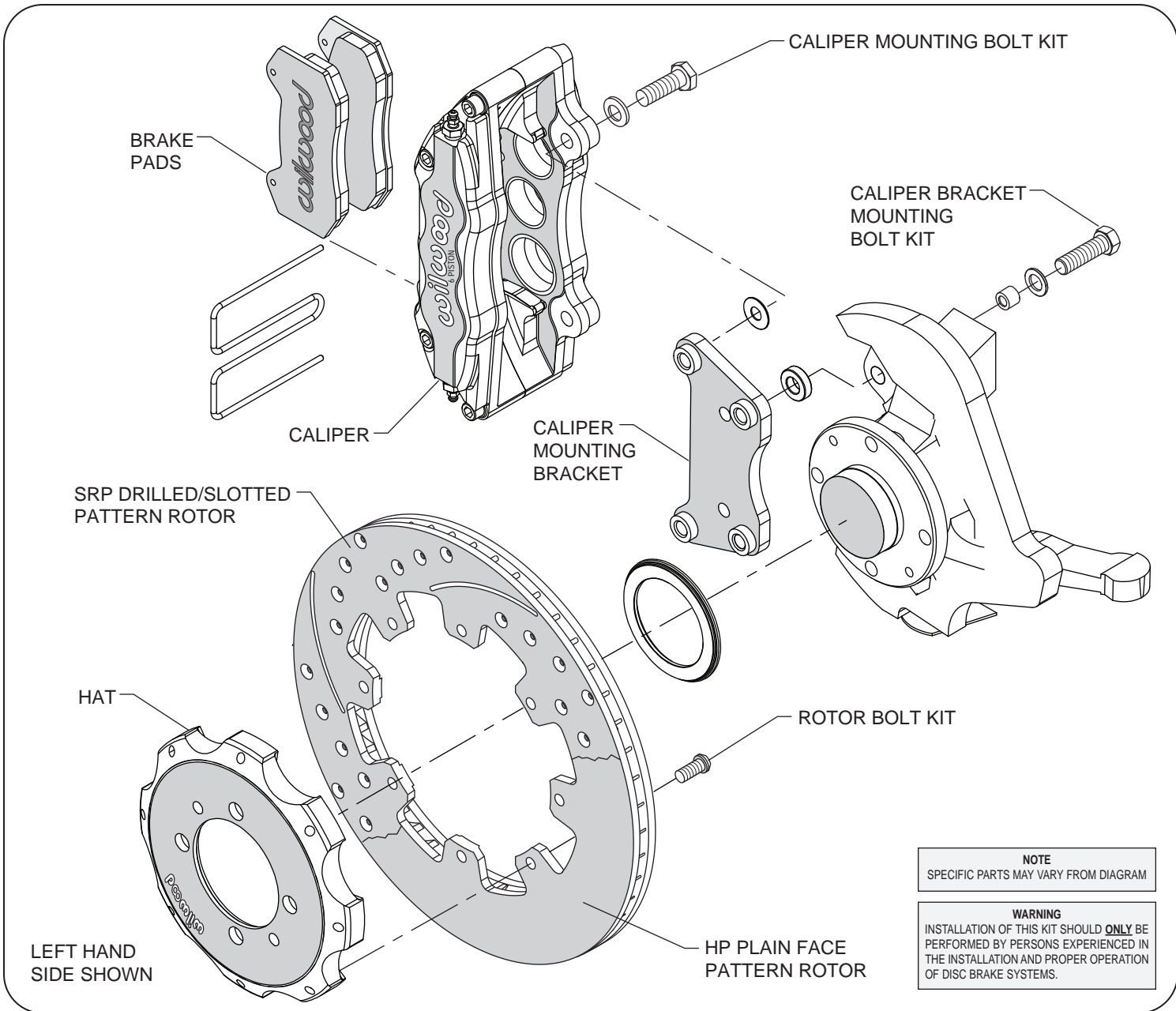

Typical Installation Diagram

ORDERING INFORMATION:

PART NUMBER	DESCRIPTION
140-12767	Front Kit, Fiat 500, DynaPro 6 Caliper, 12.19" ULHP Rotor
140-12767-D	Front Kit, Fiat 500, DynaPro 6 Caliper, 12.19" SRP Drilled and Slotted Rotor
140-12767-DR	Front Kit, Fiat 500, DynaPro 6 Caliper, 12.19" SRP Drilled & Slotted Rotor, Red Caliper
140-12767-R	Front Kit, Fiat 500, DynaPro 6 Caliper, 12.19" ULHP Rotor, Red Caliper