



# DYNALITE CLASSIC SERIES FRONT DISC BRAKE CONVERSION KIT FOR 1940-1952 OLDSMOBILE

## Models Covered:

- General Motors Oldsmobile, All Models, 1940-1952

## Kit Features:

- Front disc brake conversion provides improved stopping power for added safety and driving comfort while maintaining an unmodified outward appearance with O E or classic styled wheels.
- Fully bolt-on installation requires no modifications to spindles or suspension. Original components can be reinstalled when factory authenticity may be preferred.
- Fully compatible with OE master cylinder output when a modern tandem outlet master cylinder will not be used

## Component Features:

### Dynalite Forged Billet Four Piston Calipers

- Dynalite calipers provide big brake stopping power, rugged durability, and a long, corrosion free service life from the FEA computer designed forged billet aluminum body.
- Stainless steel pistons provide additional corrosion resistance while reducing the direct transfer of heat from the pads to the caliper body, fluid, and seals.
- “Seal-in-bore” design keeps fluid and pressure in while keeping dirt and debris out. The cumbersome look and all problems associated with external piston boot seals are eliminated.
- Black anodized finish provides additional resistance to oxidation inside and out to maintain performance and preserve their high-tech style and appearance.

### ULHP Performance 11.75” Rotors

- Premium grade carbon iron castings are precision machined to provide long service life and true running with high resistance to thermal distortion and fatigue.
- Thick faced castings with 32 internal cooling vanes maintain even temperatures and consistent performance in all types of driving conditions.
- 11.75” diameter rotors add leverage to enhance the caliper performance for overall maximized stopping power.

### Forged Aluminum Hubs and Rotor Mounts

- Forged and fully machined billet hubs mount to the OE spindles with modern grease seals and tapered roller bearings.
- Dual pattern drilled hubs with 1/2”-20 fine thread grade 8 studs can be used with either 5 on 4.75” or 5 on 5.00” lug pattern wheels.
- Bolt-on rotor mounting plates save additional weight while provide secure mounting of the brake rotor to the hub.
- Dust caps, wheel bearings, seals, and wheel studs are included with each kit

### BP-10 Compound “Smart Pads”

- BP-10 metallic composite compound “Smart Pads” provide high friction, high temperature fade resistance, and immediate positive response without the noise, dust, and rotor abrasion that is normally associated with OE type semi-metallic style pads

### Hardware and Plumbing

- Caliper brackets, alignment shims, all premium grade fasteners, and a detailed installation guide are included with each kit.
- Braided stainless steel flexline kit P/N 220-12782 is required to complete the installation, and must be ordered separately.



Front Dynalite Classic Series Kit

**WARNING**  
 INSTALLATION OF THIS KIT SHOULD **ONLY** BE PERFORMED BY PERSONS EXPERIENCED IN THE INSTALLATION AND PROPER OPERATION OF DISC BRAKE SYSTEMS.

**NOTE**  
 SPECIFIC PARTS MAY VARY FROM DIAGRAM

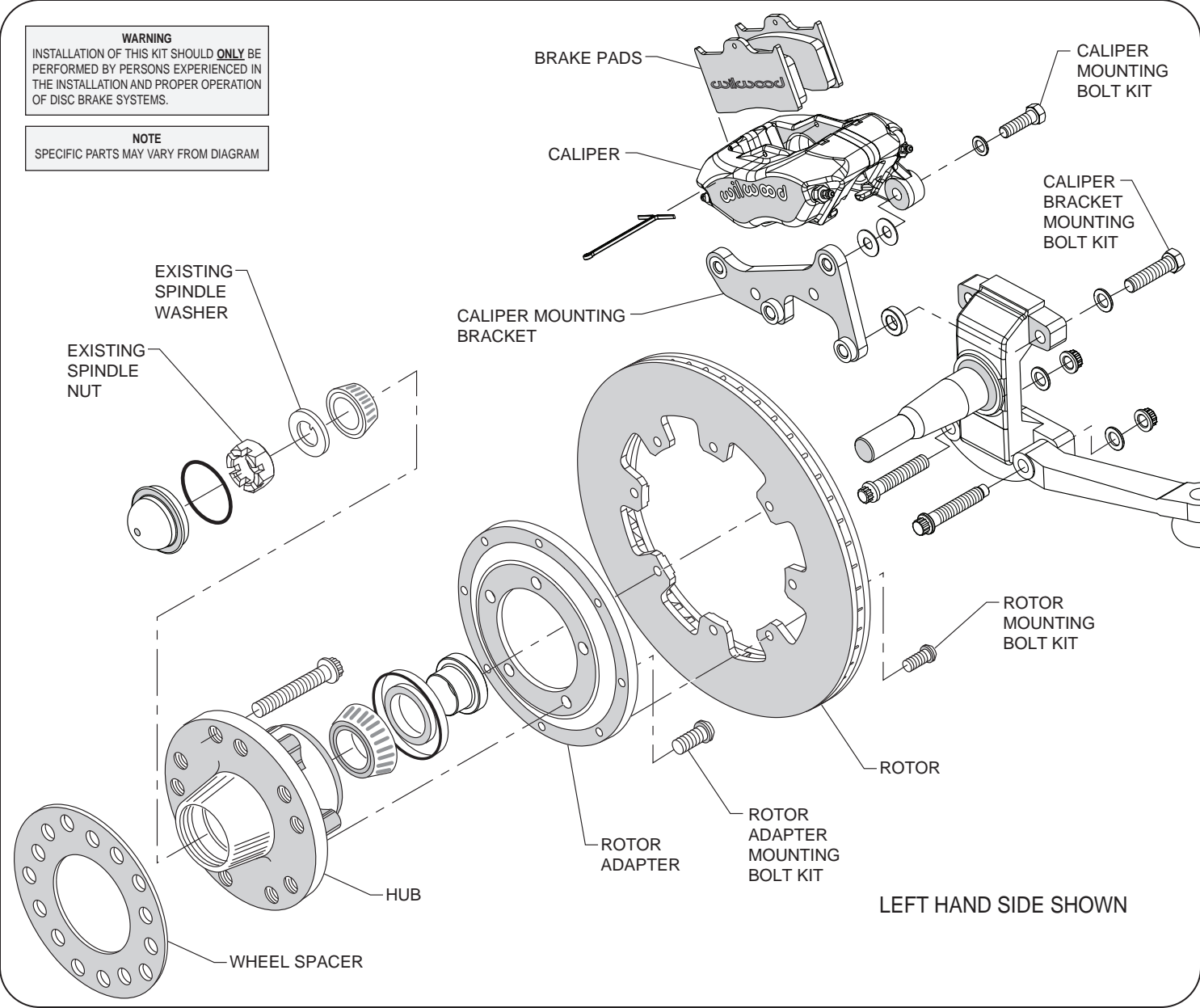

**Typical Installation Diagram**

**ORDERING INFORMATION:**

<b>PART NUMBER</b>	<b>DESCRIPTION</b>
140-12617	Front Kit, Oldsmobile, Dynalite Caliper, 11.75" ULHP Plain Face Rotor
140-12617-D	Front Kit, Oldsmobile, Dynalite Caliper, 11.75" SRP Drilled and Slotted Rotor
140-12617-DR	Front Kit, Oldsmobile, Dynalite Caliper, 11.75" SRP Drilled and Slotted Rotor, Red Caliper
140-12617-R	Front Kit, Oldsmobile, Dynalite Caliper, 11.75" ULHP Rotor, Red Caliper