



11-Inch Rear Disc Brake Kit with Internal Drum Parking Brake for First Generation 7-1/4", 4 Lug Mustang

Models Covered:

Disc Brake Kit has been specifically designed to fit first generation 7-1/4" Ford Mustang rear ends, 4 lug only

Kit Highlights:

- This Wilwood Pro Series rear disc brake kit with internal parking brake solves the problems associated with smaller diameter wheel clearances.
- Based on an 11.00" diameter rotor, coupled with our DynaPro Low-Profile caliper gives you the option of a complete four piston disc brake kit with a fully functioning parking brake for 14 and 15 inch rim use.
- Easy bolt-on installation, disc brake kits include everything necessary for a simple installation.
- Compatible with OE and aftermarket disc brake master cylinders.
- It's the ultimate look in contemporary hot rod style with unmatched performance from race-born track ready components.

Component Features:

Forged Billet DynaPro Low-Profile Calipers

- Four stainless steel pistons generate high clamping force and balanced pad loading with low heat transfer and high resistance to corrosion.
- Spring loaded stainless steel SRS bridge plates reduce noise by dampening engagement harmonics and eliminating pad rattle. SRS plates also extend caliper service life by eliminating bridge gouging at the pad trailing edge.
- Top loaded pads are easily inspected and serviced without the need to remove the caliper from the mount.
- Standard kit includes black anodized calipers. Optional red or powder coat is also available.

SRP or ULHP Series 11.00" Diameter Rotors

- For cool running and increased stopping power, each kit includes 11.00" diameter vented iron alloy brake rotors with integral hats.
- Standard kits include smooth face ULHP rotors.
- Optional SRP directional drilled and slotted rotors enhance pad performance with consistent response by cleaning and venting gasses, dust, and burnt pad material. A black E-coat finish is applied to resist corrosion and preserve the aggressive high-tech look inside the wheel.

Wilwood BP-10 Compound High Performance "Smart Pads"

- BP-10 is an exclusive Wilwood metallic composite compound. This remarkable material possesses the quiet, low dusting properties found in ceramic based street compounds, but with the higher friction, heavier load capacity, and increased fade resistance of a medium range race pad.

Internal Shoe Parking Brake

- The drum style internal parking brake provides outstanding holding power with the ultimate uncluttered custom look.
- The two shoe system is mechanically actuated and spring loaded for quiet non-rattling performance.
- Brake shoes are neatly hidden and out-of-sight inside the rotor assembly. Parking brake cables are relocated inward with more clearance for deep offset wheels.

Mounting Brackets and Hardware

- Integral mounting brackets secure the caliper and the parking brake assembly to the axle tube.
- High strength steel and performance grade nuts, bolts, and alignment shims are included to complete the secure and accurate installation.

Note:

- Clevis and cable kits, which attach to the parking brake assembly are not included in the Wilwood parking brake kit. Wilwood offers a generic style cable kit for this vehicle, order part number 330-9371.



Rear Parking Brake Kit with Red Caliper and SRP Rotor

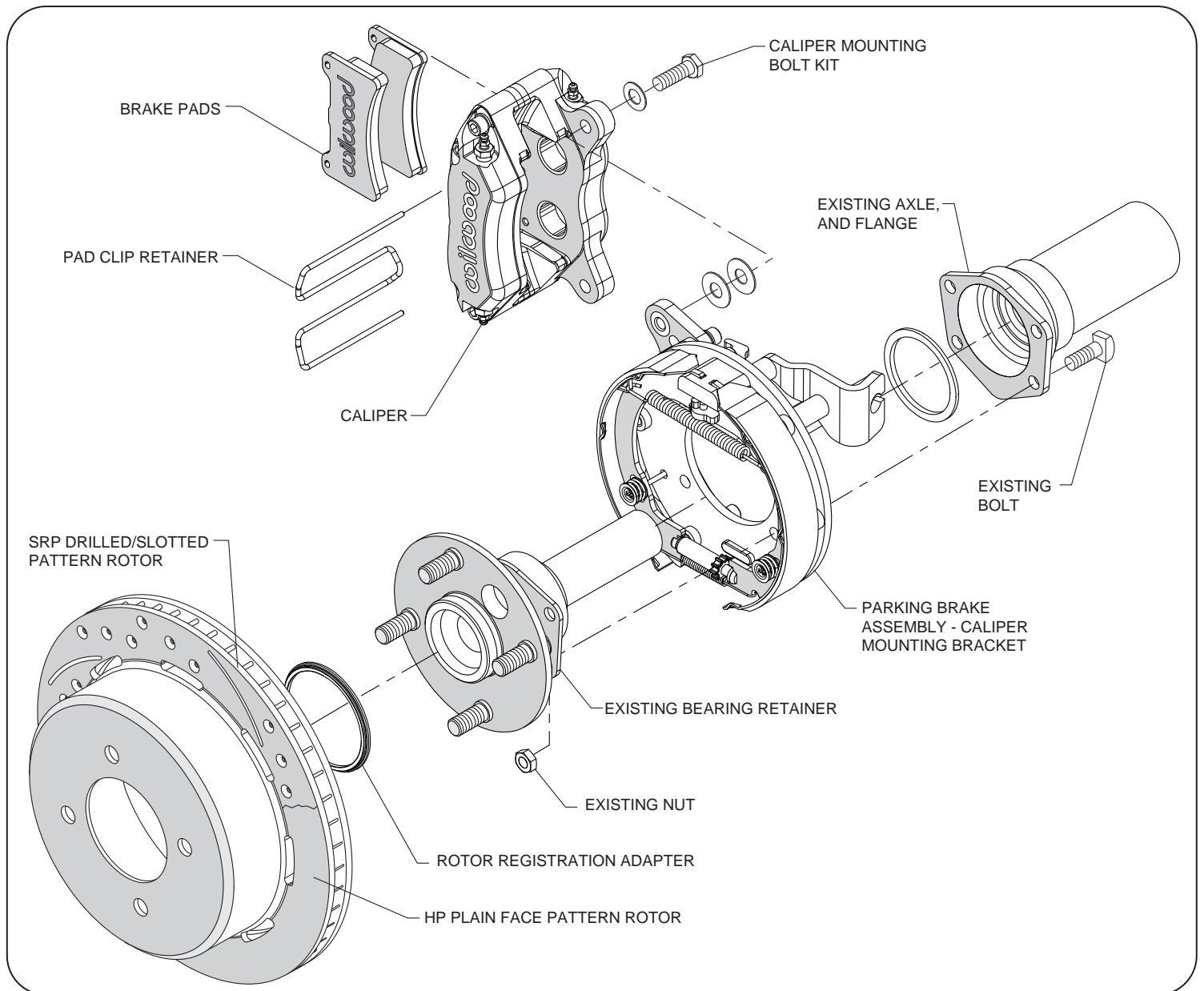

Typical Installation Diagram, Major Components Identified

ORDERING INFORMATION:

PART NUMBER

DESCRIPTION

<u>PART NUMBER</u>	<u>DESCRIPTION</u>
140-12589	Rear Parking Brake Kit, Ford 7-1/4" Mustang, DynaPro Caliper, 11.00" HP Rotor
140-12589-D	Rear Parking Brake Kit, Ford 7-1/4" Mustang, DynaPro Caliper, 11.00" SRP Drilled & Slotted Rotor
140-12589-DR	Rear Parking Brake Kit, Ford 7-1/4" Mustang, DynaPro Caliper, 11.00" SRP Drilled & Slotted Rotor, Red Caliper
140-12589-R	Rear Parking Brake Kit, Ford 7-1/4" Mustang, DynaPro Caliper, 11.00" HP Rotor, Red Caliper