



FRONT BIG BRAKE ROAD RACE KIT FOR 2005 - PRESENT FORD MUSTANG

Models Covered:

- 2005 to present Ford Mustang with OE front spindles.

Kit Features:

- Meets SCCA Specifications for A Sedan.
- Bolts to OE mounts on spindle with minimal modifications.
- Caliper piston sizes configured for manual balance bar dual master cylinder pedals.

Component Features:

Billet Superlite 4R/ST Radial Mount Calipers

- BSL4R/ST four piston differential bore calipers with Thermlock pistons provide maximum heat protection with balanced pad loading for even wear in sustained high heat competition.
- Spring loaded stainless steel SRS bridge wear plates dampen vibration and engagement noise while protecting the caliper bridges at the pad load surfaces to extend the caliper body service life.
- Center bridge bolt design adds additional strength against caliper separation and deflection under load while allowing easy access for pad service without caliper removal.
- Calipers feature Wilwood's signature and black anodized finish for improved wear, corrosion resistance and long lasting durability.



Big Brake Front Kit with GT Rotor

GT-48 Competition Series Spec 37 Directional 12.19" Rotors

- Spec 37 extreme duty alloy rotors deliver long service life with the highest degree of resistance to thermal distortion, cracking, and wear in sustained high heat competition.
- Directional vane rotors provide the highest cooling efficiency with increased surface area and improved air circulation between the rotor faces.
- Each GT rotor is fully competition prepared with asymmetrical face slotting for pad performance, full detail machining, and individual dynamic balancing for smooth running at all speeds.

Forged Aluminum GT Mounting Hats

- Fixed mount forged aluminum rotor mount hats reduce weight and provide the strength to handle high brake torque loads.
- Black anodized finish resists corrosion while adding to the aggressive competition look inside the wheel.

Wilwood PolyMatrix Brake Pads

- PolyMatrix "H" pads included in this kit provided long wear and consistent, predictable engagement with excellent release and modulation characteristics.
- High-temp, race only compound has high friction with maximum fade resistance for sustained duty use on all types of road courses and hard braking ovals.

Radial Mounting Hardware and Plumbing

- Radial mounting provides secure attachment directly to the OE mount with two planes of adjustment for precise alignment over the rotor.
- Brackets, premium grade fasteners and alignment shims are included in each kit. Installation requires only minor modifications on the OE spindle for clearance under the bracket.
- Stainless steel braided and jacket reinforced flexline kits with DOT approved whip-style ends are included in each kit.

WARNING
 INSTALLATION OF THIS KIT SHOULD **ONLY** BE PERFORMED BY PERSONS EXPERIENCED IN THE INSTALLATION AND PROPER OPERATION OF DISC BRAKE SYSTEMS.

NOTE
 SPECIFIC PARTS MAY VARY FROM DIAGRAM

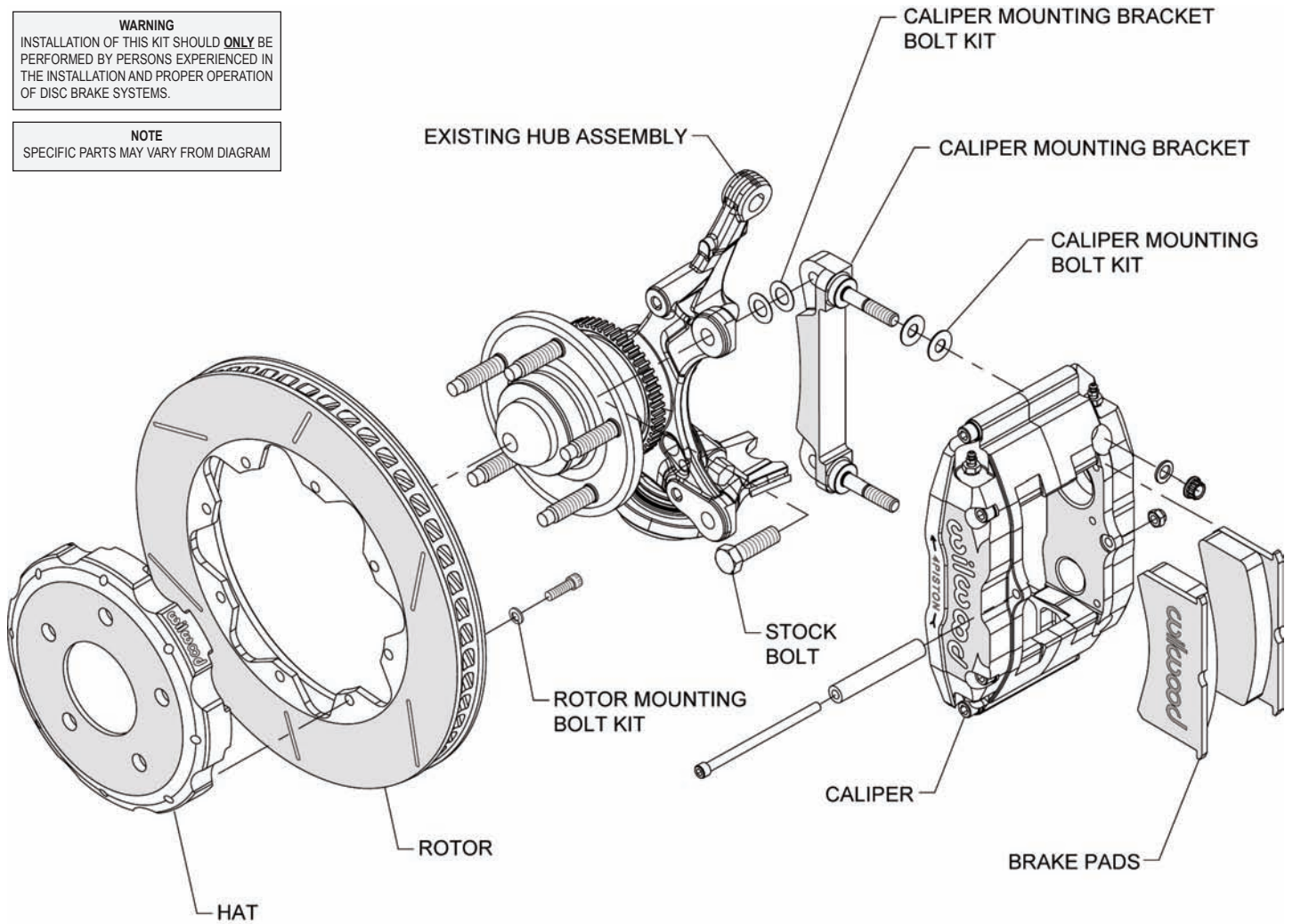

Typical Installation Diagram

ORDERING INFORMATION:

<u>PART NUMBER</u>	<u>DESCRIPTION</u>
140-12508	2005 - PRESENT FORD MUSTANG FRONT ROAD RACE KIT

ORDERING INFORMATION, USER SERVICEABLE COMPONENTS:

<u>PART NUMBER</u>	<u>CALIPER</u>	<u>GT ROTOR</u>	<u>HAT</u>	<u>AXLE SET PADS</u>	<u>BRACKET KIT (EA)</u>	<u>ROTOR BOLT KIT</u>
140-12508	120-10693/94-RS	160-11839/40	170-10040	15H-8114K	250-12524	230-2589