



DYNALITE PRO SERIES FRONT BRAKE KITS FOR CHEVROLET IMPALA AND CORVETTE

Kit Features:

- Fully bolt-on performance disc brake upgrades for use with the OE drum or disc brake spindles on all 1959-64 Impala, 1963-64 Corvette, 1965-70 Impala, and 1969-82 Corvette.
- Kits available with 11.00" or 12.19" rotors to maximize braking capacity with wheel size or style.
- Standard kits available with black anodized or gloss red sealed powder coated caliper finishes.
- Polished and black powder coated calipers available by custom order.
- Positive disc brake stopping power and big brake styling with top end performance for the street or track.

Component Features:

Forged Dynalite Four Piston Calipers

- Super high-strength forged billet alloy bodies deliver consistent pedal response and big brake performance with manual or power brake systems.
- Four stainless steel pistons per caliper provide balanced pad loading and high clamping .
- Low thermal conductivity and high corrosion resistance of stainless steel pistons provides lower caliper temperatures and longer, trouble free service life
- Spring loaded SRS bridge plates dampen noise and protect the caliper bridges from wear at the pad trailing edge

ULHP or SRP Performance 11.00" and 12.19" Rotors

- ULHP and SRP series rotors in these kits are manufactured from premium grade carbon iron. The rotors are precision machined to minimize all run-out and provide precise fit time after time.
- ULHP series rotors are close tolerance machined with a smooth face finish. ULHP rotors are preferred for all 15" front drag wheel categories or street strip categories that use OE spindles. ULHP rotors also provide long service life on the street.
- SRP series rotors feature the high performance and high-tech styling of our signature directional drill and slot pattern and durable black E-coat finish that keeps them looking good mile after mile.
- 11.00" rotor kits deliver positive disc brake stopping power with most types of 15" street and strip disc brake compatible wheels, including many OE styles.
- 12.19" rotor kits provide added brake torque capacity when upgrading to 16" or 17" wheels.

Forged Aluminum Hubs and Rotor Mounts

- Forged and fully machined billet hubs, with 1/2-20 grade 8 wheel studs mount to the OE spindle using tapered roller bearings and races.
- Machined aluminum rotor mounting plates attach the rotors directly to the forged billet hubs to comprise an extremely high strength, yet overall lightweight hub and rotor assembly

Wilwood "Smart Pads"

- Each kit includes BP-10 compound "Smart Pads". BP-10 is a unique metallic composite compound that delivers quiet, low dust performance, but with the improve response, friction, and temperature range of a semi-metallic style pad.
- Optional track day and competition only pad compounds are also available to fine tune brake response for a particular vehicle type, individual driving style, or preferences.

Brackets, Hardware, and Plumbing

- Brackets and premium grade hardware to mount the radial mount BNSL6R calipers to the OE spindle are included with each kit.
- DOT approved flexline kits, required to adapt Wilwood calipers to your chassis plumbing, are available separately by vehicle model.



Pro Series Front Kit with SRP
Rotor and Red Caliper

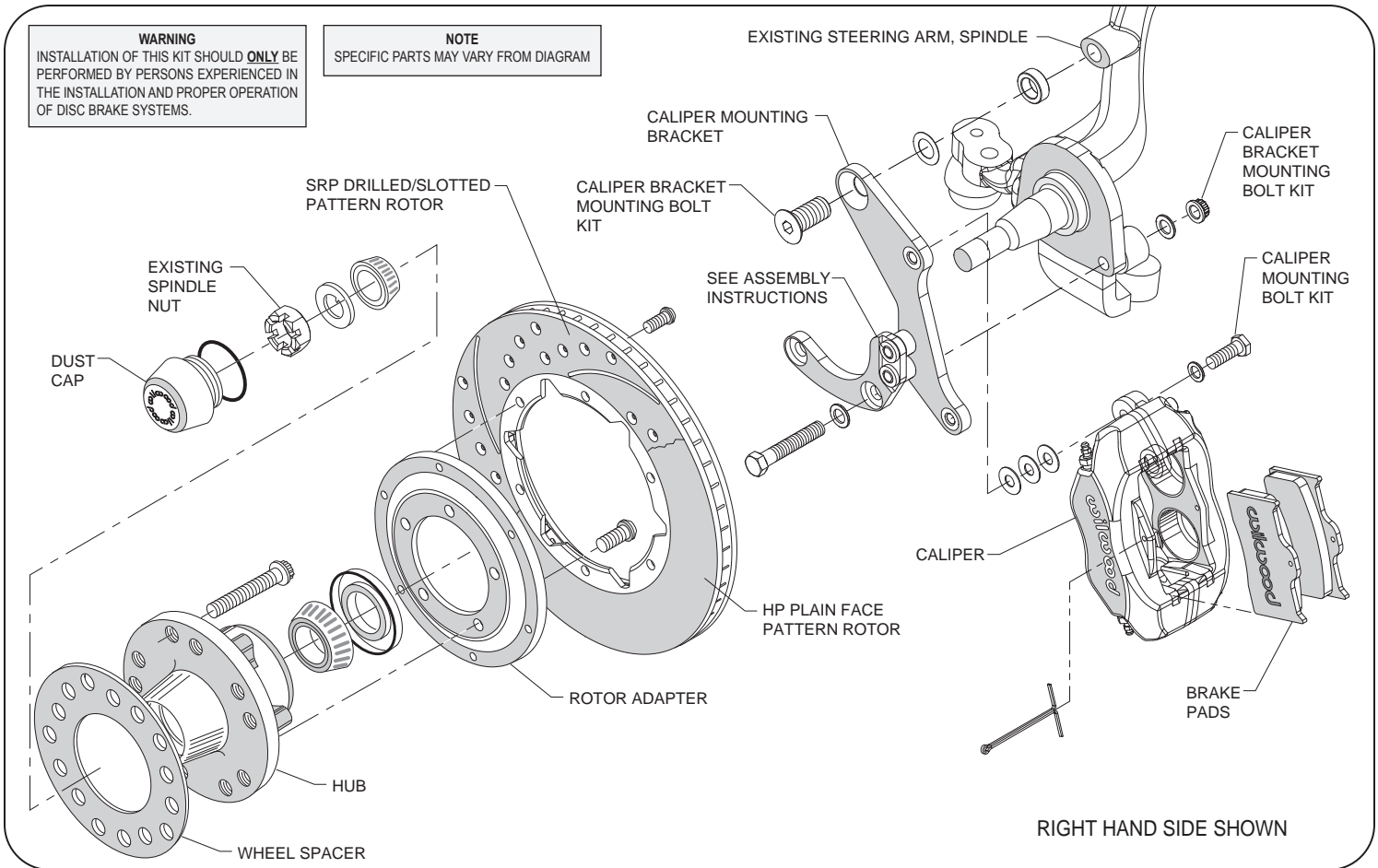

Typical Installation Diagram (11.00" Rotor Diameter Kit Shown)

ORDERING INFORMATION: 1959-64 IMPALA, 1963-64 CORVETTE DRUM BRAKE SPINDLES

<u>KIT NUMBER</u>	<u>CALIPER</u>	<u>ROTOR</u>	<u>PAD TYPE</u>	<u>FLEXLINE KIT</u>
140-12458	Black Anodized	11.00" ULHP	7112	220-7699
140-12458-D	Black Anodized	11.00" SRP, Drilled and Slotted	7112	220-7699
140-12458-DR	Red Powder Coat	11.00" SRP, Drilled and Slotted	7112	220-7699
140-12458-R	Red Powder Coat	11.00" ULHP	7112	220-7699
140-12459	Black Anodized	12.19" ULHP	7112	220-7699
140-12459-D	Black Anodized	12.19" SRP, Drilled and Slotted	7112	220-7699
140-12459-DR	Red Powder Coat	12.19" SRP, Drilled and Slotted	7112	220-7699
140-12459-R	Red Powder Coat	12.19" ULHP	7112	220-7699

ORDERING INFORMATION: 1965-68 IMPALA DRUM BRAKE SPINDLES

<u>KIT NUMBER</u>	<u>CALIPER</u>	<u>ROTOR</u>	<u>PAD TYPE</u>	<u>FLEXLINE KIT</u>
140-12021	Black Anodized	11.00" ULHP	7112	220-7699
140-12021-D	Black Anodized	11.00" SRP, Drilled and Slotted	7112	220-7699
140-12021-DR	Red Powder Coat	11.00" SRP, Drilled and Slotted	7112	220-7699
140-12021-R	Red Powder Coat	11.00" ULHP	7112	220-7699
140-12022	Black Anodized	12.19" ULHP	7112	220-7699
140-12022-D	Black Anodized	12.19" SRP, Drilled and Slotted	7112	220-7699
140-12022-DR	Red Powder Coat	12.19" SRP, Drilled and Slotted	7112	220-7699
140-12022-R	Red Powder Coat	12.19" ULHP	7112	220-7699

ORDERING INFORMATION: 1968-70 IMPALA DISC, 1969-70 IMPALA DRUM, 1969-82 CORVETTE

<u>KIT NUMBER</u>	<u>CALIPER</u>	<u>ROTOR</u>	<u>PAD TYPE</u>	<u>FLEXLINE KIT</u>
140-12040	Black Anodized	11.00" ULHP	7112	220-7699
140-12040-D	Black Anodized	11.00" SRP, Drilled and Slotted	7112	220-7699
140-12040-DR	Red Powder Coat	11.00" SRP, Drilled and Slotted	7112	220-7699
140-12040-R	Red Powder Coat	11.00" ULHP	7112	220-7699
140-12045	Black Anodized	12.19" ULHP	7112	220-7699
140-12045-D	Black Anodized	12.19" SRP, Drilled and Slotted	7112	220-7699
140-12045-DR	Red Powder Coat	12.19" SRP, Drilled and Slotted	7112	220-7699
140-12045-R	Red Powder Coat	12.19" ULHP	7112	220-7699