



1998 - 2002 CAMARO REAR BIG BRAKE DISC / PARKING BRAKE KIT

Models Covered:

Chevrolet Camaro

1998 - 2002

Kit Features:

- Designed for full bolt-on installation as an upgrade from smaller rear discs, or as a conversion from drum brakes.
- Internal shoe parking brake provides superior holding power while neatly hidden inside the bolt-on iron disc hat.
- New rear parking brake cables are easily connected to the original equipment or aftermarket hand brake levers.
- Compatible with OE and aftermarket disc brake master cylinders.
- Matched performance with competitive styling for 13" disc and larger front Big Brake kits and custom wheel upgrades.

Component Features:

Forged Billet Superlite 4R Calipers

- High strength, FEA designed forged aluminum billet bodies provide the highest clamping efficiency and lowest deflection of any caliper in its class.
- Radial mounting provides secure attachment to the rear axle while providing two planes of adjustment for precise alignment of the caliper and pads over the rotor.
- Four dust booted pistons provide balanced pad loading while sealing out dirt, moisture and other road born debris in less than friendly environments.
- Spring loaded stainless steel SRS bridge plates reduce noise by damping engagement harmonics and eliminating pad rattle. SRS plates also extend caliper service life by eliminating bridge gouging at the pad trailing edge.
- Top loaded pads are easily inspected and serviced without the need to remove the caliper from the mount.
- Standard kits include black calipers. Optional red or polished calipers are also available.



Rear Parking Brake Kit with SRP Rotor

SRP or GT Series 13.00" Diameter Rotors

- 13.00" diameter vented iron discs provide high cooling efficiency and increased leverage for big brake stopping power inside 17" and larger wheels.
- SRP directional drilled and slotted rotors enhance pad performance with consistent response by cleaning and venting gasses, dust, and burnt pad material. A silver zinc finish is applied to resist corrosion and preserve the aggressive high-tech look inside the wheel.
- GT Series rotors are competition prepared with asymmetrical face slotting, full detail machining, and individual dynamic balancing. This non-drilled version uses the additional mass to deliver improved stability in sustained high temperature applications.
- All SRP and GT rotors are close tolerance machined to less than .001" for total flatness, parallelism and run-out to assure true running at all speeds.

Wilwood BP-10 "Smart Pads"

- All kits include BP-10 metallic-composite compound "Smart Pads". BP-10 delivers the increased friction; higher fade resistance, and longer wear of an entry-level track pad, with virtually noise and dust free performance for the street.
- Optional race-only compounds can be ordered to suit the braking requirements at all levels of severe duty and sustained high heat competition.

Internal Shoe Parking Brake

- Cable actuated internal shoe assemblies generate superior holding power. The complete assembly is neatly hidden inside the rotor hat for a clean and uncluttered installation.
- Factory pre-assembled backing plates with shoes are spring loaded for positive release and rattle free operation.
- A universal cable kit for custom applications is available separately. Order part number 330-9371.

Radial Mount Caliper Brackets and Hardware

- Radial mounting provides two planes of adjustment for precise alignment of the pads and caliper over the rotor. Integral brackets secure the caliper with the parking brake assembly to the axle tube.
- Competition grade, high strength steel fasteners and alignment shims are included to complete the installation.

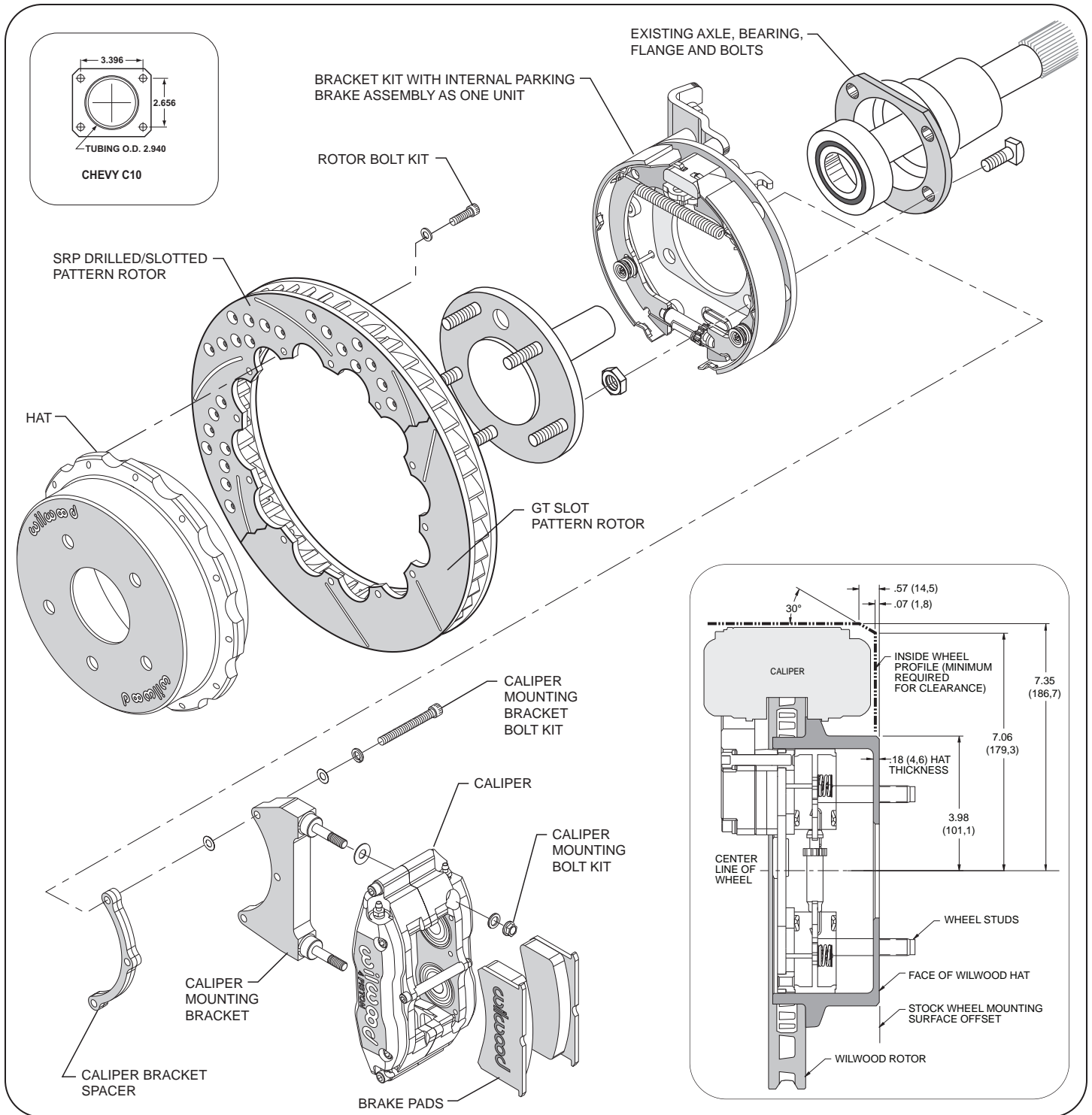

Typical Installation Diagram, Major Components Identified.

ORDERING INFORMATION:

MAKE / MODEL
Chevy C-10, 5 Lug

YEAR **HP ROTOR KIT**
2.42"

KIT PART NUMBERS
SRP ROTOR KIT **SRP ROTOR KIT**
140-10093 140-10093-D

ORDERING INFORMATION, COMPONENTS AND SERVICE PARTS:

BASE KIT NUMBER
140-10093

CALIPER
120-8062-R/L

GT ROTOR-R/L
160-6833/34

SRP ROTOR-R/L
160-6835/36

BRAKE PAD AXLE SET
150-8855K

PARKING BRAKE MOUNT BRACKET ASSEMBLY
249-10095/96