



# GRAND NATIONAL GN6R FORGED RADIAL MOUNT CALIPER



## Grand National GN6R

*forged aluminum six-piston radial mount calipers bring current state-of-the-art design, materials, and manufacturing technology to this long standing icon in the Wilwood caliper line.*

## Caliper Features



- High-strength forged aluminum body in either hard-anodized or Quick-Silver nickel plate finish
- Stainless steel pistons in base model GN6R anodized calipers
- Thermlock® pistons in GN6R/ST Quick-Silver nickel plate models
- Compatible with rotors from 1.25" to 1.38" thickness and diameters from 12.19" to 13.06"
- Two body widths available for use with .80" (20,3 mm) or .99" (25,0 mm) thick pads
- Internal fluid ports with protected single inboard bleed system
- Bolt-in center bridge adds strength and provides easy pad access
- Internal piston damping springs
- Replaceable stainless bridge plates
- Use with radial mount bracket kits for direct replacement of all 3.50" or 6.00" center lug mount GN calipers

NOTE: Use with bracket kit P/N 250-14046 for 3.50" center mounts, or bracket kit P/N 250-14048 for 6.00" center mounts.

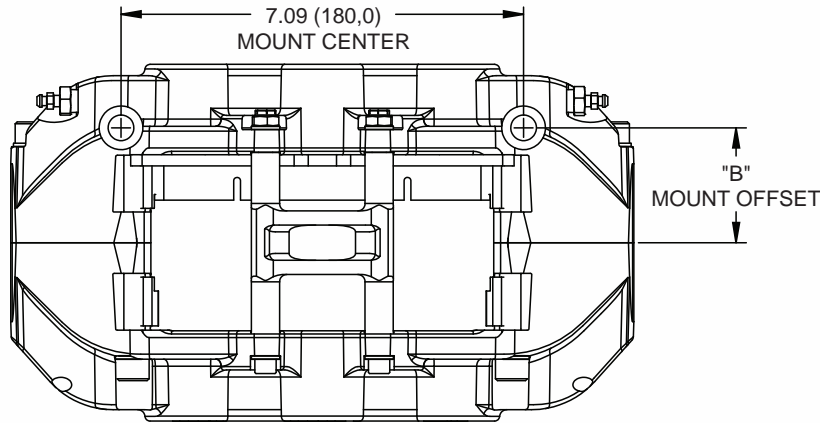

DISC WIDTH	"B" MOUNT OFFSET
1.25 (31,8)	2.02 (51,4) <sup>1</sup>
1.38 (35,1)	2.02 (51,4) <sup>1</sup>
1.25 (31,8)	2.22 (56,5) <sup>2</sup>
1.38 (35,1)	2.22 (56,5) <sup>2</sup>

DISC DIAMETER	"E" OUTSIDE RADIUS
12.19 (309,6)	6.97 (177,0)
12.88 (327,1)	7.21 (183,1)
13.06 (330,7)	7.28 (184,9)

NOTES: (1) CALIPER WITH .80 (20,3) THICK PADS  
(2) CALIPER WITH .99 (25,0) THICK PADS

DIMENSION "D1" = (DISC DIAMETER/2) - 2.33 (59,3)  
RIGHT HAND CALIPER SHOWN  
INLET FITTING: 1/8-27 NPT

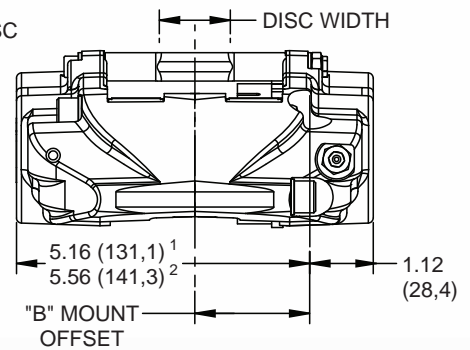
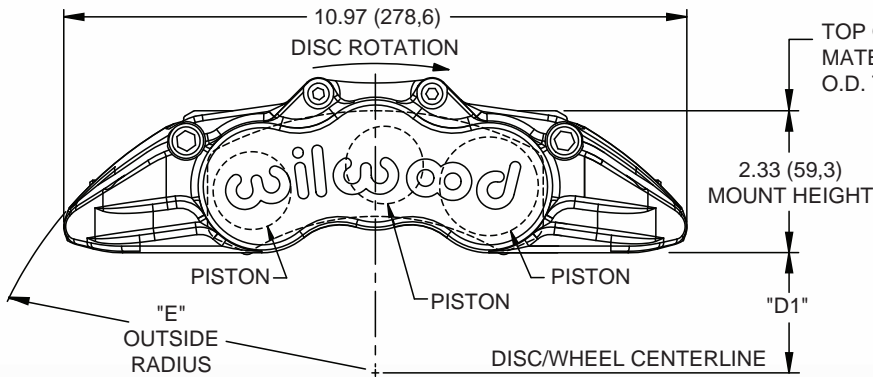

**GN6R Caliper, Dimensional Characteristics**

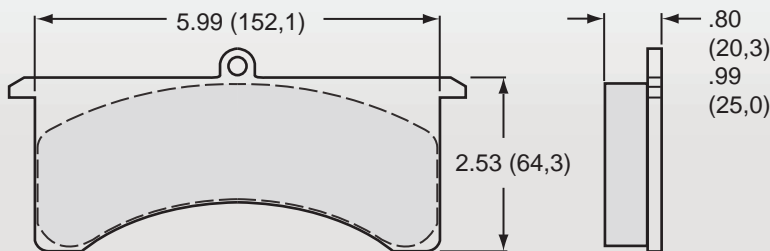

.80 AXLE SET P/N	PAD TYPE / COMPOUND	
150 - 9417K	7520-20	BP-20 <i>SmartPad</i>
150 - 12246K*	7520-40	BP-40 <i>SmartPad</i>
15A - 5736K*	7520-A	PolyMatrix A
15B - 3993K*	7520-B	PolyMatrix B
15E - 6101K	7520-E	PolyMatrix E

.99 AXLE SET P/N	PAD TYPE / COMPOUND	
150 - 13794K	7525-20	BP-20 <i>SmartPad</i>
150 - 13795K*	7525-40	BP-40 <i>SmartPad</i>
15A - 13796K*	7525-A	PolyMatrix A
15H - 13797K*	7525-H	PolyMatrix H

\*THESE PADS ARE AVAILABLE BEDDED-IN  
ADD -B TO END OF PART NUMBER WHEN ORDERING

## ORDERING INFORMATION:

CALIPER	PISTON SIZES	ROTOR WIDTH	PAD TYPE	FINISH	RIGHT HAND PART NUMBER	LEFT HAND PART NUMBER
GN6R	1.75/1.38/1.38"	1.25 - 1.38"	7520	Hard Anodized	<a href="#">120-13946</a>	<a href="#">120-13947</a>
GN6R/ST	1.75/1.38/1.38"	1.25 - 1.38"	7520	Quick-Silver	<a href="#">120-13948-N</a>	<a href="#">120-13949-N</a>
GN6R/ST	1.75/1.38/1.38"	1.25 - 1.38"	7525	Quick-Silver	<a href="#">120-13950-N</a>	<a href="#">120-13951-N</a>