



FORGED NARROW MOUNT DYNALITE CALIPER

Caliper Highlights:

Wilwood's new **Forged Narrow Mount Dynalite** (FNDL) calipers are ideal for many competition applications including late models, modifieds, sprints, off road and road racing. Computer generated design and stress analysis technology, is the latest innovation from Wilwood providing substantial improvements in strength and performance over all comparable caliper models.

Forged Narrow Mount Dynalites are the strongest calipers in the class. The process of stress-flow forging re-aligns the metal's grain structure within the contour of the caliper body. This process eliminates the breaks and interruptions to the internal grain structure that occur when machining a straight billet block. The FEA generated radial transition design eliminates steps and shoulders in the area between the piston housing body and the caliper bridges. Incorporating a radius in this transition area substantially increases resistance to deflection and caliper separation under load. Structural deflection and volume displacement tests have proven the **Forged Narrow Mount Dynalite** to outperform all existing styles of this popular caliper size. Without even considering the overall greater strength and reliability of the forging, the reduced deflection tendencies and the resulting decrease in fluid volume displacement translate to increased clamping efficiency with less pedal travel. The bottom line is a taller pedal and better stopping power. The superior strength of this innovative design is combined with proven performance features from Wilwood's earlier designs. Each caliper is equipped with Wilwood's SRS stainless steel bridge plates. The SRS plates eliminate the bridge wear caused by pad gouging and extend the service life of the caliper body. The spring-loading action of the SRS plates also eliminates pad rattle and dampens the vibration harmonics that contribute to squeal under braking. Other standard Wilwood features include high temperature seals and stainless steel pistons to eliminate corrosion and retard heat transfer from the pads. Internal fluid passages eliminate the need for external tubes. Four corner bleed screws assure simple and effective air evacuation from the system and allow one caliper to be mounted in any front, rear, right, or left position. To round out the package, **FNDL** calipers are finished in black anodize for long lasting protection in high heat environments. Polished units are also available in select piston sizes and rotor widths.



■ Black Anodize

FNDL calipers are a direct replacement for all previous Wilwood **NDL's** and similar competitive brands with 3.50" centered mounting tabs. A total of five bolts provide superior bridge strength and positive retention of the top loaded 7816 or 7216 type brake pads. The full range of PolyMatrix pad compounds are available to match the brake response and heat range requirements of any competition application.

CALIPER ORDERING INFORMATION:

| BORE SIZE | | DISC WIDTH | | PART NUMBER |
|-----------|---------|------------|---------|--------------|
| 1.75" | 44,5 mm | 1.25" | 31,8 mm | 120-11573 |
| 1.75" | 44,5 mm | 1.00" | 25,4 mm | 120-15254 |
| 1.75" | 44,5 mm | .81" | 20,6 mm | 120-11572 |
| 1.75" | 44,5 mm | .81" | 20,6 mm | 120-11572-SI |
| 1.75" | 44,5 mm | .38" | 9,7 mm | 120-11571 |
| 1.75" | 44,5 mm | .38" | 9,7 mm | 120-11571-SI |
| 1.38" | 35,1 mm | 1.25" | 31,8 mm | 120-11576 |
| 1.38" | 35,1 mm | 1.00" | 25,4 mm | 120-15255 |
| 1.38" | 35,1 mm | .81" | 20,6 mm | 120-11575 |
| 1.38" | 35,1 mm | .38" | 9,7 mm | 120-11574 |
| 1.12" | 28,4 mm | 1.25" | 31,8 mm | 120-11579 |
| 1.12" | 28,4 mm | .81" | 20,6 mm | 120-11578 |
| 1.12" | 28,4 mm | .81" | 20,6 mm | 120-11578-P |
| 1.12" | 28,4 mm | .38" | 9,7 mm | 120-11577 |
| 1.12" | 28,4 mm | .38" | 9,7 mm | 120-11577-P |

FORGED NDL CALIPER, MOUNTING DIMENSIONS:

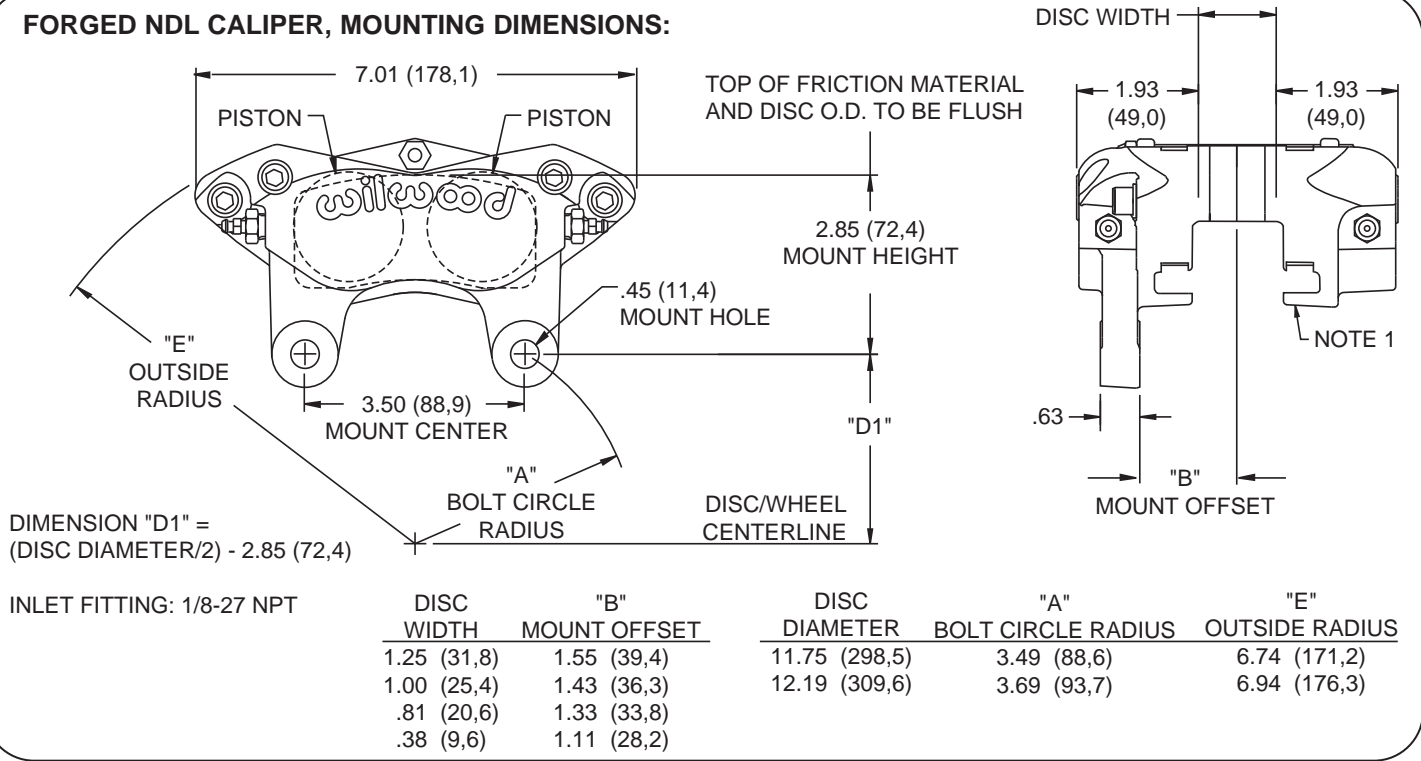

FORGED NARROW MOUNT DYNALITE, TYPE 7816 PAD DIMENSIONS AND ORDERING INFORMATION:

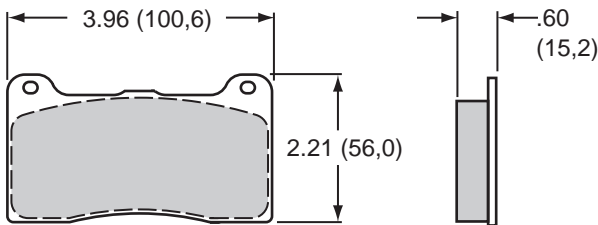

REPLACES PAD TYPE 7216

AXLE SET P/N

15A - 7263K
 15B - 7264K
 15E - 7266K
 15H - 10645K
 15Q - 7268K
 150 - 8946K
 150 - 9419K
 150 - 12248K
 150 - 9753K

PAD TYPE / COMPOUND

7816 A PolyMatrix
 7816 B PolyMatrix
 7816 E PolyMatrix
 7816 H PolyMatrix
 7816 Q PolyMatrix
 7816 10 BP-10 Smart Pad
 7816 20 BP-20 Smart Pad
 7816 40 BP-20 Smart Pad
 7816 CM For Titanium Rotor

ORDERING INFORMATION, USER SERVICEABLE COMPONENTS:

| CALIPER PART NO. | PISTON | BODY SPACER EACH | BLEED SCREW KIT (4 PK) | SRS BRIDGE PLATE (EA) | SQ RING KIT (4 PK) | BODY SEAL |
|------------------|------------------|------------------|------------------------|-----------------------|--------------------|-----------|
| 120-11571 | 200-7531 (1.75") | — | 220-0627 | 300-5876 | 130-2655 | 210-2582 |
| 120-11571-SI | 200-7531 (1.75") | — | 220-0627 | 300-5876 | 130-2655 | 210-2582 |
| 120-11572 | 200-7531 (1.75") | 300-4919 | 220-0627 | 300-5876 | 130-2655 | 210-2582 |
| 120-11572-SI | 200-7531 (1.75") | 300-4919 | 220-0627 | 300-5876 | 130-2655 | 210-2582 |
| 120-11573 | 200-7531 (1.75") | 300-4919 | 220-0627 | 300-5876 | 130-2655 | 210-2582 |
| 120-15254 | 200-7531 (1.75") | 300-4919 | 220-0627 | 300-5876 | 130-2655 | 210-2582 |
| 120-11574 | 200-7516 (1.38") | — | 220-0627 | 300-5876 | 130-2658 | 210-2582 |
| 120-11575 | 200-7516 (1.38") | 300-4919 | 220-0627 | 300-5876 | 130-2658 | 210-2582 |
| 120-11576 | 200-7516 (1.38") | 300-4919 | 220-0627 | 300-5876 | 130-2658 | 210-2582 |
| 120-15255 | 200-7516 (1.38") | 300-4919 | 220-0627 | 300-5876 | 130-2658 | 210-2582 |
| 120-11577 | 200-7513 (1.12") | — | 220-0627 | 300-5876 | 130-2579 | 210-2582 |
| 120-11577-P | 200-7513 (1.12") | — | 220-0627 | 300-5876 | 130-2579 | 210-2582 |
| 120-11578 | 200-7513 (1.12") | 300-4919 | 220-0627 | 300-5876 | 130-2579 | 210-2582 |
| 120-11578-P | 200-7513 (1.12") | 300-4919 | 220-0627 | 300-5876 | 130-2579 | 210-2582 |
| 120-11579 | 200-7513 (1.12") | 300-4919 | 220-0627 | 300-5876 | 130-2579 | 210-2582 |