



# Wilwood ProSpindles for Mustang II Suspensions

## Applications:

- Designed for increased strength, minimized weight, improved handling, and increased braking capacity on kit cars, street rods, drag cars and other custom / competition applications using Mustang II suspension geometry.

## Spindle Highlights

- **High Strength** - one piece forged steel body is lightweight, yet nearly three times stronger than cast steel OE or aftermarket pressed pin replacement spindles.
- **Common Fit** - ProSpindles use common Pinto and Mustang II wheel bearings, seals, ball joints, and tie rod ends.
- **Improved Handling** - A 1/2" taller upper spindle body improves the front suspension geometry with a higher front roll center and decreased body roll with no changes to the lower control arm, frame height, or steering linkages.
- **Two Ride Height Options** - ProSpindles are available in either stock ride height or 2" drop.
- **Increased Braking Capacity** - integral mounting bosses forged into the main body provide substantially increased anchoring security for lug or radial mount calipers on rotors up to 14".
- **Bolt-On Steering Arms** - high strength forged steel arms are supplied for front steer applications and can be inverted if necessary to improve steering characteristics such as bump steer. ProSpindles can also be used for rear steer applications with custom steering arms for correct Ackerman geometry.
- **Customized Brake Systems** - custom and competition [brake kits](#), built specific for the ProSpindle, are available ranging from 11" to 14" rotor diameters with choices for four or six piston calipers in all finishes and rotor styles.



Standard Spindle Shown Left, 2" Drop Spindle Shown Right with Detached Steering Arms (one per spindle)

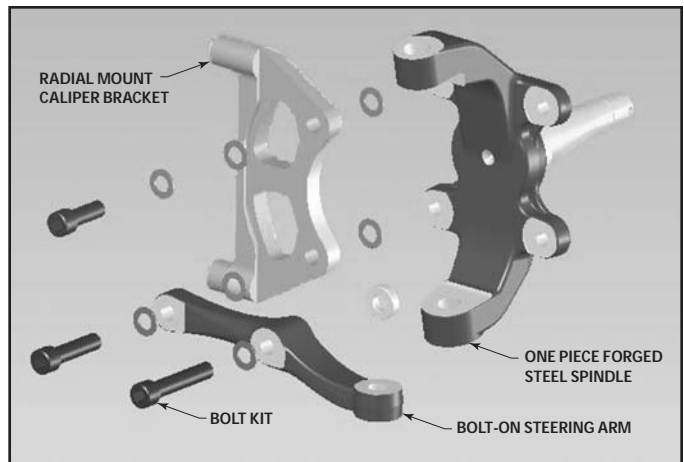

Typical View of Radial Bracket Installation

SPINDLE NO.	DESCRIPTION	QTY
830-9807	2" Drop Spindle & Steering Arm	Each
830-10832	Stock Height Spindle & Steering Arm	Each

## ORDERING INFORMATION: DISC BRAKE KITS FOR SPINDLES:

KIT PART NO.	CALIPER TYPE	CALIPER COLORS	ROTOR SIZE	ROTOR STYLE
140-9917	Forged Dynalite	Black / Red / Polished	11.00" x .810"	SRP-BLK or HP
140-9918	Forged Dynalite	Black / Red / Polished	12.19" x .810"	SRP-BLK or HP
140-9919	BNSL6R	Black / Red / Polished	12.88" x 1.10"	SRP-BLK or GT
140-9920	BNSL6R	Black / Red / Polished	14.00" x 1.10"	SRP-BLK or GT
140-10641	W6AR	Black / Red	14.00" x 1.10"	SRP-BLK or GT
140-10741	DynaPro 6	Black / Red / Polished	12.19" x .810"	SRP-BLK or HP

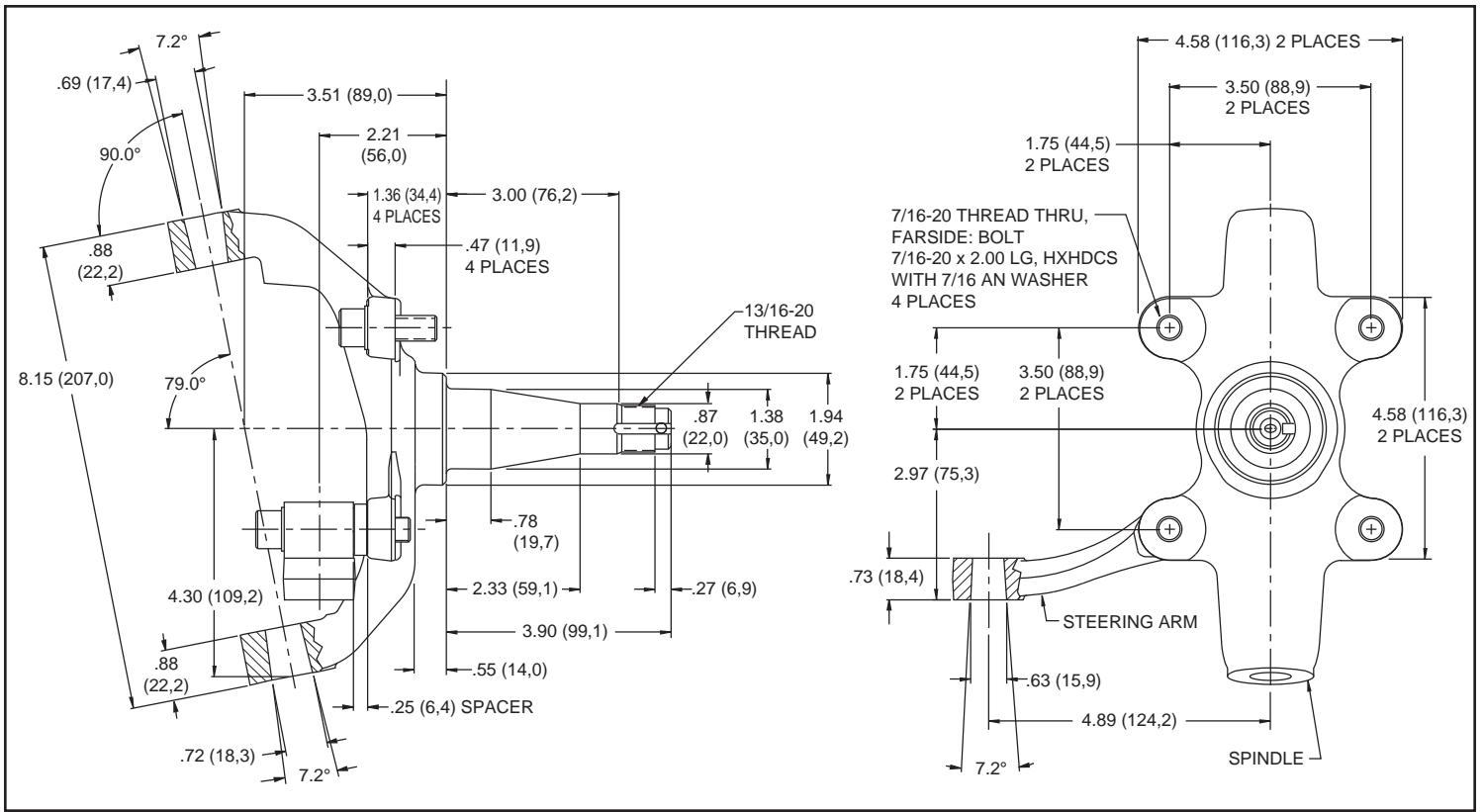

Wilwood's 2" Drop ProSpindle Assembly, Mounting Dimensions, P/N 830-9807

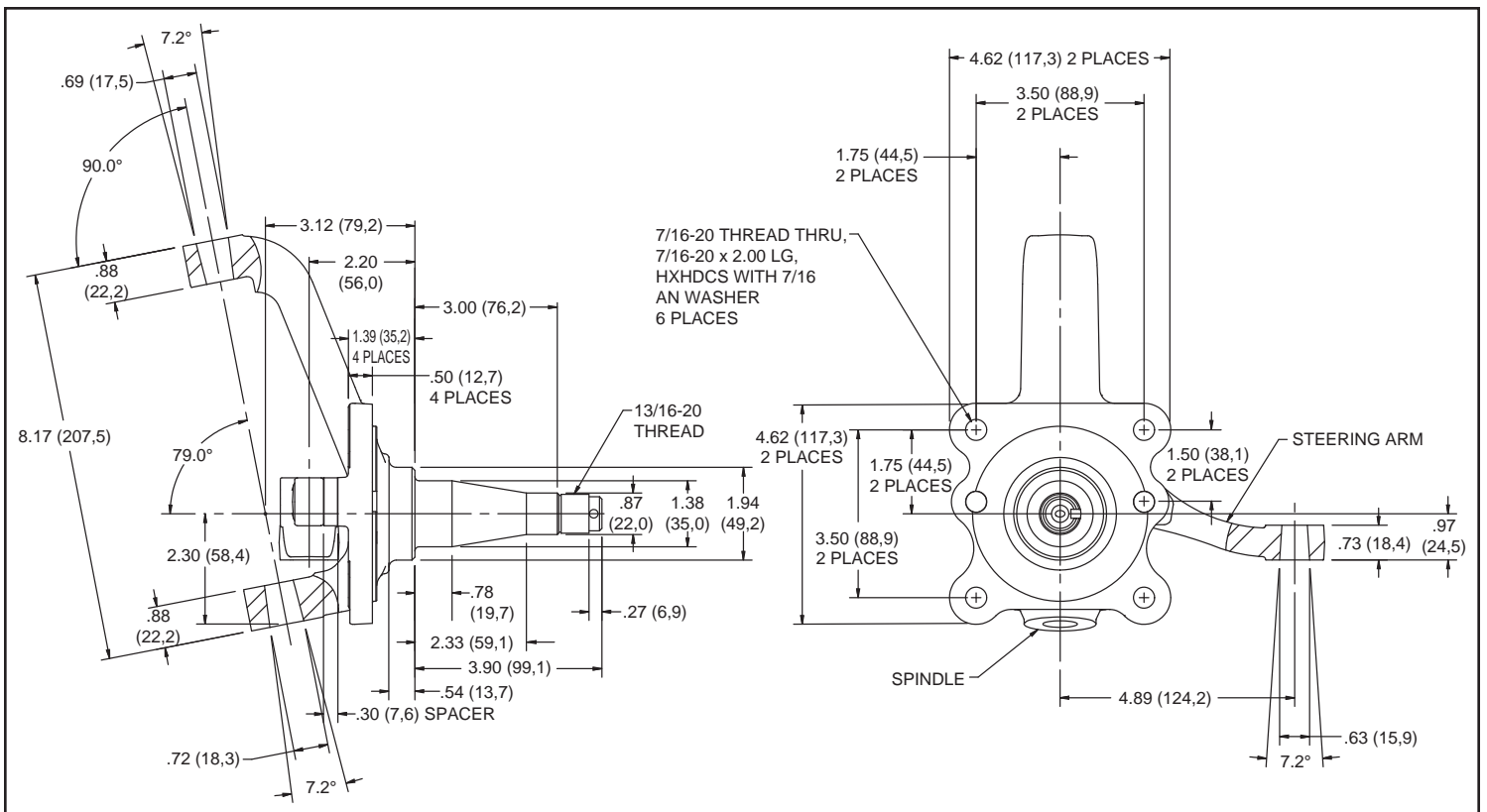

Wilwood's Standard Height ProSpindle Assembly, Mounting Dimensions, P/N 830-10832